

clear

~~TOP SECRET~~

~~TOP SECRET~~

Copy 10 of 15 copies

Each of 14 sheets

OFFICE OF THE DIRECTOR OF DEFENSE RESEARCH AND ENGINEERING
WEAPONS SYSTEMS EVALUATION GROUP
WASHINGTON 25, D.C.

~~RESTRICTED~~ COPY

CI No. 9

ENCLOSURE

COMMAND PROCESSES IN DOMINICAN REPUBLIC CRISIS
OF 30 MAY - 19 JUNE 1961

25 September 1962

INVENTORY FEB 13 1975

INVENTORY 170 NOVEMBER

TO BE RETURNED WITHIN 5 DAYS

INVENTORY MAR 3 1973

~~SPECIAL HANDLING REQUIRED~~
~~NOT RELEASABLE TO FOREIGN NATIONALS~~

The information contained in the attached document will not be disclosed to foreign nationals without the express approval of the head of the originating office. Approval shall refer specifically to this document or to specific information contained therein.

Reproduction of this document in whole or in part is prohibited except with permission of the issuing office.

THIS DOCUMENT AS A WHOLE IS CLASSIFIED ~~TOP SECRET~~.
INDIVIDUAL PORTIONS AND ATTACHMENTS HERETO
CARRY THEIR APPROPRIATE CLASSIFICATION.

INVENTORY JAN 24 1972

INVENTORY MAY 13 1968

GROUP - 1
EXCLUDED FROM AUTOMATIC
DOWNGRADING AND DECLASSIFICATION

INVENTORY JAN 23 1976

095294

Log No. TS-62-558

~~TOP SECRET~~

OSRS/DOC DU
CY R-5
FBI 637A

OASD(PA) DFOISR
80 FOI 997
Doc 1

81-TS-141 ①

R-4

~~TOP SECRET~~

HS09

~~TOP SECRET~~

ENCLOSURE

COMMAND PROCESSES IN DOMINICAN REPUBLIC CRISIS
OF 30 MAY - 19 JUNE 1961

TABLE OF CONTENTS

	<u>Page No.</u>
INTRODUCTION	1
RECAPITULATION	2
FINDINGS AND SUMMATION	6
OBSERVATIONS AND RECOMMENDATIONS OF THE DOMINICAN REPUBLIC JOINT BATTLE STAFF	6
CONCLUDING OBSERVATIONS	8
With Regard to the Role of the Joint Staff -- With Regard to Functions Required for Joint Staff Actions -- With Regard to Data Sources and Information Flow	

FIGURES

FIGURE 1 - CHRONOLOGY OF SIGNIFICANT EVENTS	3
---	---

~~TOP SECRET~~

~~TOP SECRET~~

TOP SECRET

ENCLOSURE

COMMAND PROCESSES IN DOMINICAN REPUBLIC CRISIS
OF 30 MAY - 19 JUNE 1961

INTRODUCTION

1. This is one of a number of analyses the purpose of which is to learn from recent practical experience at the national military level as much as possible about the problems and processes of command and control in crises and limited engagements. It is intended to be viewed as the initial step in a process to insure as accurate as possible a determination of what happened in the crisis under study and as realistic as possible an assessment of the relevance and significance of the results presented.

2. The requirement to achieve high accuracy needs little comment. Analyses based upon less than full and accurate information would be misleading or incomplete, or both. Although in many instances the relevance and significance, to the analyst, of an action, a time lapse or an information process may appear to be obvious, there are other cases in which that is not so or where other information available elsewhere may place an "obvious interpretation" in question. The comments, suggestions and reactions of you and your staff on these two points are being sought as the next step in the process.

3. The attached analysis is presented in two parts:

Attachment "A": An Analysis of Decision Making in U.S. Command and Control During the Dominican Republic Crisis of 30 May - 19 June 1961

Attachment "B": A Functional Analysis of Joint Staff Involvement in the June 1961 Dominican Republic Crisis

Since it is much easier to follow and to appreciate the functional analysis with a clear picture of the events of

TOP SECRET

~~TOP SECRET~~

the crisis in mind, it is recommended that the attachments be studied in the above-listed order. For the same reason, the recapitulation of the general nature of the crisis, observations on it, and chronology of significant events, all as developed in Attachment "A", are set forth in the subsequent paragraphs prior to the findings and summation from Attachment "B".

RECAPITULATION
(From Attachment "A", p. 125)

4. The Dominican crisis was from the beginning, and remained, essentially political. It never had an intrinsically military dimension, other than that which was misread into it by some agencies of the U.S. Government. Nevertheless, it was a classic example of the use of force as a policy instrument. The U.S. military response was addressed to a political condition, rather than a military situation, and the strategic objectives it was intended to serve were accordingly political in nature and for a policy purpose. However, no clearly defined "enemy," against whom force would be employed, was identified, initially or later, and in a relatively short period of time the original "friendly forces" (the dissidents) were replaced by new ones (the Government), to whom political support was extended and military support promised.

5. The peak of intensity of the military phase of the crisis, as interpreted and reacted to by the U.S., occurred at the beginning (31 May - 1 June) and progressively declined thereafter. (See Figure 1.) Conversely, the national decision against intervention was not a climactic discrete event but an evolving process. It gradually emerged and

~~TOP SECRET~~

FIGURE 1
CHRONOLOGY OF SIGNIFICANT EVENTS

~~TOP SECRET~~

CHRONOLOGY OF SIGNIFICANT EVENTS

1960

- 20 Aug OAS condemns Dominican Republic; votes breaking of diplomatic ties and imposes economic sanctions.
- 26 Aug U.S. breaks diplomatic relations with Dominican Republic.
- 17 Nov JCS approves military contingency plan for Dominican Republic.

1961

- 4 Jan OAS votes further sanctions against Dominican Republic.
-

- 5 May NSC directs preparation of Political Contingency Plan for Dominican Republic.
- 15 May Political Contingency Plan approved by President.
- 29 May Copy of Political Contingency Plan sent to Consul General in Ciudad Trujillo.
- 30 May (~2200) Trujillo assassinated.
- 31 May (~0500) First report of assassination (unconfirmed) reaches Washington.
- 31 May (0919) Vice DJS alerts CINCLANT.
- 31 May (1124) CINCLANT places Naval forces on DEPCOM 3, and Army and Air Force units on DEPCOM 4.
- 31 May (1256) Trujillo assassination report confirmed.
- 31 May (1600) State-Defense meeting decides to prepare for military intervention.
- 31 May (1626) CINCLANT orders deployment of Naval units.
- 31 May (~1800) DJS activates Dominican Republic Battle Staff.

1961

- 1 Jun (~0800) JCS Dominican Republic Battle Staff becomes operational.
- 1 Jun (~1030) JCS meeting decides to augment contingency forces, doubles strength.
- 2 Jun (~1700) Letter requesting U.S. intervention received from General Estrella.
- 2 Jun (2330) State-Defense meeting decides not to respond to Estrella request.
- 3 Jun Consul General reports reign of terror in Dominican Republic.
- 4 Jun Consul General offers Balaguer U.S. military support.
- 5 Jun Consul General recalled.
- 6 Jun Venezuela advises against military intervention.
- 6 Jun (~1000) State Dept. meeting decides no immediate U.S. military action to be taken.
- 7 Jun Arrival of OAS Observers in Dominican Republic.
- 7 Jun (2137) COMSECONDPFLT proposes holding training exercise.
- 9 Jun State-JCS meeting decides to reduce U.S. military readiness posture.
- 12 Jun JCS meeting decides to authorize training exercise.
- 15 Jun OAS Observers leave Dominican Republic.
- 16-17 Jun Exercise AXLE GREASE conducted.
- 17 Jun Deployed Naval units begin return to CONUS.
- 19 Jun JCS Dominican Republic Battle Staff disestablished.

1-7-61-1A

~~TOP SECRET~~

FIGURE 1

TOP SECRET

took form de facto over a period of time (seven days) before it was institutionally adopted as a formal decision and given official sanction.

6. Political intelligence proved to be the overriding problem of command and control, before and during the crisis. Defense-State coordination and prior planning had been more fully accomplished prior to this crisis than ever before and State-Defense cooperation throughout the event was more effective than ever before. Despite this, the political intelligence system had been unable to perceive the nature of the crisis or isolate the critical factors in it in pace with the speed of events and the concomitant urgency of decision requirements. Before the crisis, strategic political intelligence on which policy and planning had been based was faulty: the character of the coming crisis had been wrongly surmised; the capabilities of the dissidents, miscalculated; and the resourcefulness and stability of the Government, misjudged. During the crisis, tactical political intelligence had been inadequate to the needs of command and control, both political and military, for day-to-day decisions in the management of U.S. action: at times, the salient features of the current internal political situation within the Dominican Republic were unknown, confused, or erroneous; at other times, when known correctly, were learned too late. By default, in the absence of reliable and timely political intelligence, operating premises for decisions were almost exclusively dependent upon past assumptions, policies, and objectives as stipulated in plans, sometimes with little relationship to contemporary circumstances.

7. Besides the lack of adequate political intelligence, a major constraint upon command and control was the built-in constraint of plans, particularly the Political Contingency Plan.

TOP SECRET

~~TOP SECRET~~

The combination of preciseness but incompleteness represented in its limited spectrum of anticipated contingencies and alternative options tended to truncate arbitrarily the range of choice permitted decision makers, until the deficiency was discovered and additional possibilities considered. The rigidity and inertia of precommitment in the form of a plan had, in this case, the effect of inhibiting both flexibility and speed of response.

8. Military response, once committed to a course of action, is, because of its mass, inherently less flexible than political response, which it follows and to which it is functionally subordinate. There was thus, in the Dominican crisis, a time lag before the military course of action under way could be altered in compliance with a change of political objectives. In view of the radical degree of change of political objectives experienced during the crisis, the military response (in the form of force deployment in preparation for intervention) proved to be out of phase shortly after it was initiated and required some ten days before being brought back again into phase with policy. The time lag was directly proportionate to the mass and momentum of the military commitment.

9. Of special significance to military command and control is that U.S. decision behavior in the Dominican Republic crisis manifested a pronounced tendency toward elevation of tactical issues into strategic issues and a resulting centralization of military operational decision making at the seat-of-government level. Many issues that, in themselves, were technically only minor military concerns, were frequently seen as threshold acts potentially constituting a national commitment with policy implications or strategic consequences. The degree of caution exercised in this regard accounts for the instances of such issues being preempted and resolved as national decisions.

~~TOP SECRET~~

~~TOP SECRET~~

~~TOP SECRET~~

10. Politico-military operational issues also ended up as strategic issues. Because of no coordination or decision-making machinery being provided for at lower echelons of authority, wherever political factors impinged upon military operational considerations the problem was invariably referred upward, to be dealt with by national decision makers. In view of the brevity of the military phase of the crisis, the decision time delay involved often prevented decisions on these issues from being rendered in time to be of utility or relevance in meeting the operational requirements that raised them.

11. Central to and controlling U.S. command and control throughout the Dominican Republic crisis were the nonmilitary aspects of decision making. Among these, the most crucial was political intelligence. In the final sense, only political intelligence can provide the basis for discriminate decisions to effect optimum military response in a predominantly political context.

FINDINGS AND SUMMATION
(From Attachment "B", p. 46.)

OBSERVATIONS AND RECOMMENDATIONS OF THE
DOMINICAN REPUBLIC JOINT BATTLE STAFF

12. Soon after the June 1961 JBS was dissolved, the Battle Staff members wrote a critique of their own operations. The following observations and recommendations were made:

a. Reaction times of assigned and augmentation forces are almost always briefing subjects for high-level meetings. These reaction times vary from day to day, and official statements from the action commander should be requested by plans checklists as soon as an emergency threatens and as any significant change occurs. This was done during the Dominican situation and should be SOP.

~~TOP SECRET~~

b. Details of contingency plans are requested by JCS and higher echelon personnel which are covered only in component commanders' or lower echelons' plans not usually available in the Joint Staff. Such detailed briefings should be given by the commander's staff when the situation warrants. The plans checklist should provide for a briefing team or liaison officer from the CINC's to be made available to the Joint Staff for this purpose.

c. Standard format briefing book outlines should be developed now, with contents established for contingency plans, and amended as necessary during emergencies for the Secretary of Defense, CJCS, Director J/S, and Director J-3.

d. Plans checklists should provide for potential Battle Staff members to "be briefed early and given a reading list to further read themselves into the problem."

e. Normally, transportation plans are not completed until months after approval of OPLANS. Battle Staffs should be aware that OPLANS of recent date may not have completed transportation plans and must expect to encounter problems in this area.

f. After last-minute changes to force tabs in a contingency plan, "it takes longer than you think it will" to revise supporting plans. Major problems in implementation of operational plans must be expected during the period when changes are under way.

g. Members of the Battle Staff will often be absent from battle staff duties for lengthy periods to perform briefings for the JCS. To preclude having to remove officers with operational responsibilities from the watch for briefing purposes, it is recommended that a Colonel-Captain grade officer be placed on each watch with the primary responsibility of following the situation, anticipating briefing

requirements, and preparing and giving briefings. ("It should also improve the briefings.")

h. The physical facilities of the situation rooms were barely adequate for this situation, and any situation of larger scope would be difficult to administer in these facilities. (Since this time, the Battle Staff Room has been enlarged and further expansion is planned.)

CONCLUDING OBSERVATIONS

13. All of the observations of the JBS critique except for the last (concerning physical facilities available) are supported by data developed in this functional analysis. (All of the Dominican Republic Joint Battle Staff (DR JBS) suggestions have been considered by Joint Staff officers concerned with plans for future Battle Staffs. The degree to which they have been implemented has not been ascertained in this phase of the study.) Additional observations and conclusions from each of the main sections of this study are listed below.

14. To reiterate, the purpose of this study is to present a record of Joint Staff functions performed and information flow during a crisis situation. This is a collation of previously widely separated information presented to inform people of what went on, and hopefully to allow subsequent evaluation of such crisis situation operations. This study is not an evaluation itself. Conclusions, therefore, are limited to a summation of some of the more interesting observations as to data developed.

With Regard to the Role of the Joint Staff

15. The Joint Chiefs were constrained in their direction of the military effort during this crisis by the need for coordination and approval of many of their military decisions with

political authority at the State Department and White House. The reaction time of the Joint Staff was determined by these constraints, and the nature of such constraints was not immediately foreseeable. The DR JBS role was greatly influenced by these JCS-State and Presidential relationships, in that a large amount of JBS effort was required in preparation of detailed explanations of military capabilities and potential military courses of action for high-echelon coordination with political authority.

16. The largest workload for the JBS was in the first week of its existence -- the time when the Battle Staff was first formed and least experienced. The DR JBS did, in fact, provide a readily accessible focal point for Joint Staff handling of Dominican Republic operations. However, its creation diverted all J-3 staff work concerning this situation to the JBS area and added coordination functions for the other J's efforts to the J-3 workload.

With Regard to Functions Required for Joint Staff Actions

17. The greatest amount of time in development of Joint Staff actions was spent in deciding that certain information required J/S action and determining what type of action should be taken. The second greatest time requirement was for approval of proposed actions. Neither of these functions was performed by the JBS, but both required nearly full-time attention of JBS members. The JBS was usually required to draft action proposals, but this function was usually a very minor time consumer.

18. Determining what Joint Staff action was advisable and obtaining approval for action recommended required more lateral coordination, went through more echelons, and consequently took longest in the subject areas of providing policy guidance

~~TOP SECRET~~

to theater forces and handling of State Department information. There was no established procedure for the Joint Staff to inform theater commanders of national policy, and no clearcut channel for developing and passing on State-generated information as intelligence for use of theater forces. Approval by the President of key actions proposed by the JCS sometimes took as long to obtain, but at least the method of obtaining Presidential approval seems to have been clear.

With regard to Data Sources and Information Flow

19. The Joint Staff was very largely dependent on State Department messages for intelligence with regard to the situation in the Dominican Republic. Procurement of these messages was generally slow and there are gaps in continuity of these messages as received in the Joint Staff. State messages were also a key source of potential policy guidance information and, to some extent, were used as such by Joint Staff retransmittal to the theater commander.

20. The staff members of the JBS were completely dependent on general officers briefing them on JCS and State-Defense decisions concerning the Dominican Republic situation. The JBS had action assignments which required such information on every known higher echelon decision. Although in this particular instance, this informal method of informing JBS members as to high-level decisions reached and information circulated appears to have been fairly satisfactory, it is not clear that such would always be the case.

21. The JBS was held responsible for keeping the Joint Staff informed of intra-Service actions following through on JCS directives. The JBS was dependent upon the Services for this background information, and informal contacts with the Service War Rooms were used to lay on Joint Staff requirements. This

~~TOP SECRET~~

~~TOP SECRET~~

method provided fairly complete documentation of Army and Navy actions (when coordination copies of messages were usually transmitted to Headquarters), but did not provide enough detail on Air Force actions to keep the Joint Staff informed (most of the Air Force actions being conducted directly between commands without information copies to Headquarters). Service information taking the longest time to reach the Joint Staff was contained in messages from subordinate to theater commanders and readdressed as info copies to headquarters or the JCS.

~~TOP SECRET~~

~~TOP SECRET~~

~~TOP SECRET~~

RETIREMENT COPY

Copy of 15 copies
Each of 134 sheets

OFFICE OF THE DIRECTOR OF DEFENSE RESEARCH AND ENGINEERING
WEAPONS SYSTEMS EVALUATION GROUP
WASHINGTON 25, D.C.

CI #1

ATTACHMENT "A"

AN ANALYSIS OF DECISION MAKING IN U.S. COMMAND AND CONTROL DURING THE DOMINICAN REPUBLIC CRISIS OF 30 MAY - 19 JUNE 1961

25 September 1962

INVENTORIED
APR 14 1969

21 FEB 1974 INVENTORIED

INVENTORY JAN 19 1976

INVENTORY OCT 18 1968

SPECIAL HANDLING REQUIRED
NOT RELEASABLE TO FOREIGN NATIONALS

The information contained in the attached document will not be disclosed to foreign nationals without the express approval of the head of the originating office. Approval shall refer specifically to this document or to specific information contained therein.

Reproduction of this document in whole or in part is prohibited except with permission of the issuing office.

THIS DOCUMENT AS A WHOLE IS CLASSIFIED TOP SECRET.
INDIVIDUAL PORTIONS AND ATTACHMENTS HERETO
CARRY THEIR APPROPRIATE CLASSIFICATION.

INVENTORY

INVENTORY JAN 20 1972

INVENTORY FEB 10 1975

GROUP - 1
EXCLUDED FROM AUTOMATIC DOWNGRADING
AND DECLASSIFICATION.
LIMITED DISTRIBUTION

~~TOP SECRET~~

DIO

095306

Log No. ~~49-62-452~~

OASD(PA) DFOISR 81-TS-141 (2)

R-4 (COOR noc#2)

ATTACHMENT "A"

AN ANALYSIS OF DECISION MAKING IN U.S. COMMAND AND CONTROL DURING THE DOMINICAN REPUBLIC CRISIS OF 30 MAY - 19 JUNE 1961

TABLE OF CONTENTS

	<u>Page No.</u>
PURPOSE	1
SCOPE AND METHOD	1
LIMITATIONS	1
INTRODUCTION	2
BACKGROUND	2
U.S. PREPARATIONS FOR THE CRISIS	6
	<u>6</u>
MILITARY CONTINGENCY PLANS	7
NATIONAL SECURITY COUNCIL DECISIONS	9
DIPLOMATIC PREPARATIONS	10
THE POLITICAL CONTINGENCY PLAN	11
BEGINNING OF THE CRISIS	18
INITIAL MILITARY REACTION	19
INITIAL POLITICAL REACTION	21
DEPLOYMENT OF FORCES	23
ACTIVATION OF THE DOMINICAN REPUBLIC BATTLE STAFF	26
INCREASING THE FORCE COMMITMENT	29
TACTICAL INTELLIGENCE PROBLEMS	29
DECISION TO AUGMENT FORCES	33
POSITIONING OF FORCES	37
THE INTELLIGENCE DILEMMA	39
INDICATIONS AND CONTRA-INDICATIONS	39
OVERESTIMATING THE SITUATION	44
MILITARY READINESS BUILD-UP	48
REQUEST FOR U.S. INTERVENTION	53

b1
s

TABLE OF CONTENTS (CONTINUED)

	<u>Page No.</u>
OPERATIONAL PROBLEMS	56
MULTILATERAL COORDINATION	56
DEPLOYMENT AND SECURITY CONSIDERATIONS	61
POLITICAL INTELLIGENCE	65
PERCEPTION OF THE POLITICAL SITUATION	65
CONCEPTION OF A REIGN OF TERROR	66
END OF THE DISSIDENTS' ROLE	69
THE NATIONAL INTELLIGENCE IMPRESSION	71
MILITARY REACTION TO THE INTELLIGENCE IMPRESSION	72
BEGINNINGS OF A STRATEGY READJUSTMENT	75
THE CONSUL GENERAL'S PROPOSAL	75
INFLUENCE OF ALLIES' VIEWS	77
RECALL OF THE CONSUL GENERAL	79
LULL IN THE DOMINICAN SITUATION	79
POLITICO-MILITARY OPERATIONAL QUESTIONS	81
POLITICAL GUIDELINE REQUIREMENTS	81
PSYCHOLOGICAL WARFARE REQUIREMENTS	81
DEGREE OF FORCE ISSUES	85
RULES OF ENGAGEMENT	86
ACHIEVING MILITARY READINESS	89
FORCE READINESS STATUS	89
FORCE READINESS ESPRIT	92
POLICY REAPPRAISAL	96
THE CLARIFYING POLITICAL INTELLIGENCE INDICATORS	96
POLICY REVIEW	98
POLITICAL FRAMES OF REFERENCE FOR MILITARY ACTION	101
DECISION ANTICIPATED	104
COMPLETION OF THE MILITARY BUILD-UP	106
DECISION AGAINST INTERVENTION	108
FINAL STRATEGIC ASSESSMENT	108

TABLE OF CONTENTS (CONTINUED)

	<u>Page No.</u>
THE OFFICIAL DECISION	110
IMPLEMENTING THE DECISION	113
DEPARTURE OF OAS OBSERVERS	115
REDUCING MILITARY READINESS POSTURE	117
EXERCISE AXLE GREASE	117
FURTHER REDUCTION OF READINESS	118
OAS OBSERVER TEAM FINDINGS	120
END OF THE MILITARY PHASE OF THE CRISIS	122
RECAPITULATION	125
 <u>FIGURES</u> 	
FIGURE 1 - CHRONOLOGY OF SIGNIFICANT EVENTS	129

ATTACHMENT "A"

AN ANALYSIS OF DECISION MAKING IN U.S. COMMAND
AND CONTROL DURING THE DOMINICAN REPUBLIC
CRISIS OF 30 MAY - 19 JUNE 1961

PURPOSE

1. This paper is a critical historical reconstruction of the substance and circumstances of decisions in relation to events during the Dominican Republic crisis of 30 May through 19 June 1961. It is intended to provide an empirical case study of the substantive form and dynamics of the decision-making process operative in command and control as experienced in one recent crisis situation that confronted the U.S.

SCOPE AND METHOD

2. The subject of inquiry is concerned with the total national response to the crisis, both military and political, both strategic and tactical. The methodology of investigation employed is a historiographic analysis of the informational instruments by which decisions were formed and articulated, with special emphasis on the context, requirements, and rationale of those decisions. The data base for the analysis is largely philological evidence, confined for the most part to documented official information from primary sources of record generated in the course of the crisis itself, but also including testimonial information from individuals who had had a direct participating role in the crisis, and supplementary information derived from open sources.

LIMITATIONS

3. A significant limitation upon the study is the unavailability of certain pertinent data of record existing in JCS, OSD,

CIA, State Department, and Executive Office files. Hence, where unavoidable, resort is made to first-order inferences and interpolations in order to bridge hiatuses in the narrative account. These are either explicitly identified as such or are contextually self-evident.

INTRODUCTION

4. The Dominican Republic crisis that was precipitated by the assassination of Trujillo on the night of 30 May 1961 found U.S. national posture largely prepared, both militarily and politically. [] and prospective courses of action addressed to various likely contingencies were accordingly formulated in considerable detail beforehand; military operational planning, particularly, was well advanced. Tactically, however, the timing of the crisis came as a surprise, and its character was not what had been expected. Thereby the institutions and processes of U.S. decision making were put to the test of reconciling, in the heat of crisis, discrepancies between assumptions on which preparations had been predicated and realities presented by the moment. The demands thus placed on the command and control system to generate a discriminate response appropriate to both policy needs and the circumstances of the situation at hand demonstrated the strengths and weaknesses of the system's structure, procedures, and means.

BACKGROUND OF THE CRISIS

5. The conjuncture of forces that brought about the crisis came from both internal and external sources and was long in the making. In the late 1950's, the Trujillo regime, as one of the last of the classic caudillismo dictatorships surviving in Latin America, was an anachronism increasingly resented at home and

abroad. A slowly burgeoning ground swell of moral indignation and demand for political change began to build up within the country and among the Dominican Republic's Caribbean neighbors. Only somewhat belatedly did the United States get involved.

6. During the years immediately preceding the crisis, U.S. policy toward the Dominican Republic experienced a complete reversal. From a spirit of cordiality and mutual cooperation, it passed through a transitional period of ambivalence and equivocation, then gradually turned to opposition. In the context of the postwar revolutionary currents sweeping Latin America, association with the Trujillo dictatorship, which hitherto had been of some pragmatic value, had now become an embarrassing liability, and the "Benefactor's" growing predilection for political intrigue and military adventures lowered further the flash point in the already volatile Caribbean area.

7. Once U.S. policy settled on its new direction, it rapidly gained focus, specificity, and momentum. By 1959 it clearly aimed at disassociating the U.S. from any identification with Trujillo that might imply approval or support. Before the year was out it became expressly anti-Trujillo. Overt criticism of the regime and encouragement of democratic reforms brought the estrangement in U.S.-Dominican relations to its first open break on 4 December 1959, when the U.S., at the request of the Dominican Government, withdrew its naval mission. Early the following year the State Department announced that U.S. military aid to the Dominican Republic would be terminated as of June 1960. Thereafter, U.S. policy addressed itself to intensifying the forces for change in the Dominican situation. To this end a more or less systematic program of diplomatic moves and economic measures was pursued in an effort to isolate the country and influence its political character.

8. Through 1960 the regime, beset by mounting pressure from outside, increasing disaffection within, and an economy under severe strain, went into defensive retrenchment. Several concessionary steps were taken to quiet criticism and soften government policy. On 9 February Trujillo promised free multi-party elections, and on 1 April resigned as head of the Dominican Party (the only effective political party), announcing that he did so in order to clear the way for new parties to be formed to participate in the promised elections. Then on 3 August, President Hector Trujillo, the dictator's brother, resigned, being succeeded by Vice President Joaquin Balaguer, a career public official not closely identified with Trujillo family politics. This last move, however, was less a voluntary gesture than the painful reflex of being "hoisted with one's own petard."

9. The preceding June the Trujillos had indulged themselves in an ill-advised escapade. A Dominican-instigated coup against the Venezuelan Government, one of the most vociferous critics of the Trujillo regime, culminated in an abortive assassination attempt on the Venezuelan President on 4 June, in which President Betancourt was injured. Cogent evidence of Dominican complicity was uncovered and Venezuela promptly brought formal charges against the Dominican Republic before the Organization of American States (OAS). It was only after it became clear that the OAS was preparing to return a true bill and would likely impose severe penalties that Hector had felt constrained to resign.

10. Although the Trujillos thus retreated into the background, they nevertheless retained their control of the tightly integrated political-military-economic power structure as before.

11. On 20 August the OAS Conference of Foreign Ministers, meeting in San Jose, Costa Rica, passed, under U.S. leadership, a

~~TOP SECRET~~

unanimous resolution (20 members, not counting the Dominican Republic) condemning the Dominican Republic and voting sanctions against it, for "acts of aggression and intervention" against Venezuela, specifically, for having taken part in a plot to assassinate Betancourt and overthrow the Caracas Government. Strong measures were invoked: OAS members were called upon to break diplomatic ties with the country; a complete arms embargo was ordered; and "partial interruption of economic relations" was imposed. Most of the OAS members complied with the sanctions voted. The U.S. severed diplomatic relations with the Dominican Republic on 26 August, but retained consular relations.

12. Early in 1961, on 4 January, the OAS Council, meeting in Washington, D.C., voted further economic sanctions against the Dominican Republic, calling for restrictions or curtailment of exports and imports of certain commodities. On 19 January, in accordance with the new sanctions, the U.S. announced a ban on oil and truck exports to the Dominican Republic.

13. Thus the Dominican Republic was ostracized and quarantined by her fellow American nations. Internally, stresses and tensions born of popular dissatisfaction and unrest, fed by bitter antagonism of Dominican exile groups, and an ominous stirring of underground dissident movements beginning to erode the power structure, all pointed to ultimate collapse of the Trujillo regime. It was inevitable that the U.S. play a leading role in the drama.

~~TOP SECRET~~

U.S. PREPARATIONS FOR THE CRISIS

[14]

1



[15]

1/ (TS) "Talking Paper for the JCS for the JCS Meeting - 15 May 1961," prepared by J-5 Contingency Plans Branch, 15 May 1961;
(S) J-3 Dominican Republic SitRep 1-61, prepared by JCS Dominican Republic Battle Staff (hereinafter referred to as J-3 Dom Rep Battle Staff Sit Rep), 1 Jun 61.

MILITARY CONTINGENCY PLANS

16. Military planning for the crisis, however, achieved considerable explicitness at an early stage. This was incidental to the normal discharge of military responsibility for the general defense mission in the area, which required planning preparations for contingencies that might result in armed intervention by the U.S. Hence, the operation plans that were produced were done so without particular reference to the crisis, other than generically encompassing such a situation as a type. Furthermore, not being concerned with the policy issues surrounding a political decision for armed intervention, they could thus deal with operational problems on the basis of military considerations exclusively. They were, literally, technical plans for implementing one kind of decision only.

17. [] approved by JCS on 17 November 1960, was designed to cope with various contingencies in the CINCLANT area of responsibility requiring use of U.S. forces, among which was the possibility of an internal crisis in the Dominican Republic. Specifically, it was Appendix IV to Annex G of the Plan, along with its supporting [] that covered this particular contingency. It provided for a range of actions and degrees of force short of general war, from a "show of

~~TOP SECRET~~

force" and evacuation of U.S. nationals, on the one extreme, to amphibious and airborne assault followed by subsequent ground combat operations and military occupation, on the other. The flexibility was intended to allow for a discrete magnitude of force selectively applied in accordance with whatever conditions obtained at the time the execution of the plan might be ordered.

18. []

[]

19. []

[]

~~TOP SECRET~~

20. [LANT] remained the basic plan governing U.S. military action throughout the crisis. A major change indeed proved necessary during the crisis itself, after execution of preliminary military moves was under way, but this was only the increase in magnitude of force commitment that had been provided for in general terms in the original plan. Otherwise its substantive provisions were deemed adequate to the needs presented by the actual event it was intended to accommodate and were retained essentially intact.

NATIONAL SECURITY COUNCIL DECISIONS

21. By early May 1961 the prognosis for the deteriorating conditions in the Dominican Republic clearly indicated a crisis was coming. One critical incident could upset the precarious stability and topple the regime, bringing chaos momentarily. In these circumstances the overriding concern of the U.S. was that the coming crisis would present an irresistible opportunity for Communist/Castroist exploitation, to move into the ensuing power vacuum and seize control. The continuing ascendancy of Castroism, and particularly its demonstrated ambitions toward the Dominican Republic, were seen as jeopardizing the U.S. position not only in the Caribbean area but throughout Latin America, thus potentially a threat to basic national interests that had to be thwarted at all costs. The immediacy and gravity of the situation gave it an urgent salience demanding the attention of decision makers on the highest governmental level.

I/ (TS) CINCLANT (Dominican Republic, 17 Nov 60.

~~TOP SECRET~~

22.5

DIPLOMATIC PREPARATIONS

23. On the same day, following the NSC meeting, the Secretary of Defense assigned responsibility for initiating and coordinating arrangements for multilateral intervention action, in compliance with the Presidential decision, to the Assistant Secretary of Defense for International Security Affairs.^{2/} But earlier,

^{1/} (TS) NSC Action No. 2423, Record of Actions, NSC, 483rd Meeting, 5 May 1961, see also (TS) Memo, Sec Def to JCS et al., "U.S. Policy Toward the Dominican Republic and Haiti (U)" 9 May 1961; and JCS 1976/366, 15 May 1961.

^{2/} (TS) Memo, Sec Def to Asst Sec Def (ISA), "Multi-Nation Forces for Maintenance of Order in the Dominican Republic," 5 May 61; JCS 1976/366, 15 May 61.

~~TOP SECRET~~

~~TOP SECRET~~

preliminary diplomatic steps closely related to this specific objective had in fact already been undertaken by the State Department in the larger context of coping with the Castro/Communist threat in the entire Caribbean area. Later, when the need for effecting the arrangements became urgent, the local U.S. Ambassadors, under State Department supervision, conducted the actual negotiations.

24. As far back as 20 April, [] when the subject was tentatively broached, had indicated a willingness on the part of [] to act in unison with the U.S. in forestalling any Castro invasion of the Dominican Republic or other Caribbean nation, [] By early May the possibility of establishing a multinational Caribbean Security Arrangement within the framework of the OAS, in which [] was being explored. An outline plan for creating such a proposed organization in three stages, an essential element of which would be a standing Caribbean Security Force, was developed and on 9 May circulated to U.S. embassies concerned, for information, guidance and comment. []

[] However, before the proposed multilateral security system could be pursued further, it was overtaken by events, and the U.S. tried to make an interim bilateral arrangement directly with [] to deal with the immediate problems posed by the Dominican crisis.

THE POLITICAL CONTINGENCY PLAN

25. Meanwhile, the preparation of plans by the Task Force on Cuba that had been directed by the NSC at its meeting of 5 May []

~~TOP SECRET~~

~~TOP SECRET~~

went ahead apace. By 15 May an overall Political Contingency Plan for the Dominican Republic was completed and approved by the President.^{1/} It contained a statement of the situation, U.S. policy objectives, and the respective courses of action that would be taken in various contingency developments. A copy of the plan was forwarded by the Secretary of State to the U.S. Consul General in Ciudad Trujillo, in the form of a message, on 29 May, one day before the crisis began. No copy was provided to his military counterpart, COMSECONDFLT, who would be responsible for any action taken by U.S. armed forces under the plan in connection with the Dominican situation, until 8 June, after the plan was no longer current and was in the process of being revised.

26. The Political Contingency Plan for the Dominican Republic set forth as its basic assumption the observation that the Trujillo regime was in serious trouble, with opposition increasing and the removal of Trujillo himself possibly imminent. The strategic concern of "paramount interest" to the U.S. was to prevent Castro/Communist or other unfriendly elements from gaining control, while at the same time insuring that Trujillo be succeeded by a pro-U.S., democratic government.

27. The anti-Trujillo opposition, it stated, was divided into two groups: exile movements, which were infiltrated by Communists and Castroites, and the internal dissident movements. During the preceding year a moderate group of these internal dissidents, who appeared to meet U.S. requirements for an acceptable successor government to replace the Trujillo regime, had emerged and was being encouraged by the U.S.

^{1/} (TS) State Memo for Mr. Richard Goodwin, "The Current Situation in and Contingency Plans for the Dominican Republic," 15 May 61.

~~TOP SECRET~~

28. U.S. support of this moderate dissident group, however, had to be cautious because of the risks involved. If Trujillo were successfully overthrown, world opinion would criticize the U.S. for subverting an existing constitutional government. But more important -- in view of the recent Cuban experience -- if the capabilities of the group were miscalculated and its attempt proved unsuccessful, "U.S. prestige would plummet." Moreover, if the true character of this group were being misinterpreted, U.S. support might be helping to create a "Dominican Castro." Finally, there was the risk that U.S. support might prompt the group to take action prematurely, before it or the U.S. were ready.

29. [

~~TOP SECRET~~

30. The following U.S. courses of action in relation to the respective contingencies enumerated below would govern the U.S. response to the situation:

a. In the event of Trujillo's overthrow and an acceptable provisional government were established, the U.S. would:

- (1) Immediately recognize such a government.
- (2) Upon receipt of a request from this government for military assistance "against a real or anticipated external threat," dispatch U.S. forces, up to and including the landing of troops, who would have as a "concomitant objective" the "stabilization of an internal situation acceptable to the U.S."
- (3) Keep undesirable Dominican exiles from returning to the Dominican Republic.
- (4) At the same time, encourage the provisional government to request the assistance of other friendly democratic nations, e.g., Venezuela and Colombia, and to notify the OAS, possibly inviting OAS observers into the Dominican Republic. []

b. In the event Trujillo were removed but the friendly moderate dissident group was unable to establish itself, either because of pro-Trujilloists or Castro/Communists seizing control or because of complete political collapse resulting in a state of chaos, the U.S. would:

- (1) In anticipation of such an eventuality, have the U.S. Consul General in Ciudad Trujillo, when so authorized,

~~TOP SECRET~~

try to obtain beforehand from the friendly dissident group a presigned request for U.S., Venezuelan, and OAS help.

(2) In the absence of a presigned request, issue stand-by instructions to the U.S. Consul General to urge, when circumstances warrant, the moderate pro-U.S. group to declare itself to be the provisional government and to request such help.

(3) Upon notification by the U.S. Consul General that Trujillo had been removed from power, or his removal appeared reasonably certain, immediately position U.S. military forces so as to be able to reach Dominican territory with a minimum of delay.

(4) Upon notification by the U.S. Consul General that he had received a request for military assistance from an acceptable group that had declared itself a provisional government and had taken "any reasonable or plausible steps" so to constitute itself, immediately move U.S. forces into the Dominican Republic.

c. In the event Trujillo maintained himself in power for an indefinite period, the U.S. would:

(1) Continue to give encouragement to the internal dissidents.

(2) Intensify propaganda criticism, exposure, and condemnation of the Trujillo regime through the Voice of America, statements by U.S. officials, and public information media.^{1/}

31. Despite the attempted encyclopedic scope and structuring of the plan, the three contingencies projected therein proved not to encompass all of the possible eventualities that developments in the Dominican situation could assume. As it turned out,
1/ (TS) Msg, Sec State to Ciudad Trujillo, 752, 29 May 61.

~~TOP SECRET~~

the actual circumstances of the crisis took a different form, one that did not correspond to the parameters of any one of the discrete contingencies so carefully posited in the model, but manifesting, instead, a complexity and ambiguity touching upon two of them in combination and introducing an unexpected fourth. As a result, the mutually exclusive courses of action predicated on each of the three contingencies were rendered largely inapplicable. The anomaly that the crisis presented in this regard will be examined in detail later in the study.

32. Another deficiency was the failure to include provisions for effective politico-military command and control on the operating level in the arena of action. Neither an authority was designated nor organizational machinery or procedures established for achieving coordination on matters involving both political and military considerations or on activities in one sphere reciprocally affecting those in the other. It did not even provide for direct channels of informational contact between the responsible military commander and the ranking diplomatic representative. Presumably, whatever coordination would be required would be done on the national, seat-of-government level, with the only command and control jurisdiction in common, embracing both political and military decisions, exercised by the Executive Office. In this regard, it was by a fortunate coincidence that the new State Department Operations Control Center had been activated just three days before the crisis and was in a position to provide a central facility, as a focal point of contact for interested agencies, through which a measure of interdepartmental coordination on politico-military matters could be achieved during crises. It thus served as the political counterpart to the military facility represented by the JCS Joint War Room and Battle Staff.

33. Nevertheless, the Political Contingency Plan, along with its ancillary military contingency plan [] constituted the plan of U.S. response to events in the Dominican Republic that was in effect and governing on U.S. decisions when the crisis occurred. Insofar as it served as a precommitment, the deficiencies contained therein functioned as constraints upon the range of permissible choices open to decision makers and operators, and at the same time did not provide ready means for timely improvising of new alternatives.

BEGINNING OF THE CRISIS

34. May 30th was the day the crisis was precipitated by the assassination of Trujillo, although the U.S. had no knowledge of the event until the next day. The timing was apparently random, yet it was inopportune as far as the U.S. was concerned. Not only was that date the Memorial Day holiday, but it found the President and the Secretary of State preparing to leave the country the following day for an extended period to confer with de Gaulle and Macmillan in connection with the June 3rd meeting with Khrushchev in Vienna. As it turned out, when news of the assassination reached the U.S. Government on the 31st, the President left for Paris as scheduled, but the Secretary of State, on instructions of the President, delayed his departure one day in order to remain in Washington during the crucial early stages of the crisis.^{1/} Furthermore, the Director of the Operations Directorate of JCS (J-3), accompanied by many of his staff, was at the time also on a trip to Europe, from which he did not return until the crisis was almost over, and the JCS Operations Directorate itself was in the process of major reorganization. Despite these inauspicious conditions the U.S. was able to set in motion a rapid, controlled response of great complexity.

35. Shortly before 0300 hours^{2/} on the morning of 31 May the first indication that Trujillo had been assassinated the preceding night reached Washington. An exclusive CRITIC message of exceptionally limited distribution, which reported unconfirmed and unevaluated information to this effect, was received and passed to certain select addressees. At 0700 hours

^{1/} New York Times, 1 Jun 61, p. 1; 2 Jun 61, p. 1.

^{2/} Note: All times given in the text, unless otherwise identified, are in local time, i.e., Eastern Standard or "R" time, inasmuch as both Washington, D.C. and the Dominican Republic are located in the same time zone; times given in the footnote citations have all been converted to a common standard of "Z" time.

~~TOP SECRET~~

a similar message from the U.S. Consul General in Ciudad Trujillo also reported unconfirmed information that Trujillo had been killed on the night of 30 May by a dissident action group and stated that the Consul General himself had run into road blocks and search parties not long after the time of the reported assassination; he was standing by waiting to be contacted by the dissidents. Actually this latter message from the Consul General had been filed (sent) with the commercial cable company in Ciudad Trujillo, on whose facilities the consulate depended for telegraphic communications with CONUS, at 0200 hours in the early morning of 31 May, but because Dominican authorities had ordered all outgoing cable traffic suspended, the message was not transmitted by the company until 0700 hours, after the suspension was lifted.

INITIAL MILITARY REACTION

36. In the light of the news concerning the Dominican Republic, CINCLANT -- presumably on his own initiative as a precautionary move -- took action even before the reports were confirmed. He

1/ (S) Msgs, Ciudad Trujillo to Sec Def et al., 1274, 310700Z; 1277, 312400Z, May 61; Memo for Record "Incomplete message received from Mr. Achilles. State: 1274 0200 NIACT" 31 May 61 1100Z.

2/ [redacted]
3/ [redacted]

4/ (S) Msg, Ciudad Trujillo to Sec Def et al., 1277, 312400Z May 61.

~~TOP SECRET~~

~~TOP SECRET~~

notified commanders who would be involved if military action were to result that the situation might require U.S. intervention in the near future on short notice. He so advised the following: Commander Joint Task Force 122 (CJTF 122), the capacity in which the Commander Second Fleet (COMSECONDFLT) would function in the event [] were executed; Commanding General Continental Army Command (CG CONARC), who would provide Army forces; Commander Tactical Air Command (COMTAC), who would provide Air Force forces; and Commander-in-Chief Atlantic Fleet (CINCLANTFLT), who would provide naval forces. They were requested to review their plans in support of [] accordingly.^{1/}

37. At 0919 hours the Vice Director of the Joint Staff directed CINCLANT to have the naval forces listed in Appendix VI to Annex G (Dominican Republic) of his [] make preparations to implement the plan on short notice. CINCLANT was instructed, however, not to alert Army and Air Force units for the time being, but only to apprise them of the situation.^{2/} At 0948 CINCLANT ordered that the naval forces earmarked for and in support of the Joint Task Force (JTF 122) for contingency operations in connection with the Dominican Republic be placed on DEFCON 4, while the Antilles Defense Command (Caribbean Sea Frontier) was placed on DEFCON 3. However, at the JCS meeting that morning it was agreed that all forces participating in [] be placed on alert status of DEFCON 3, which subsequent to the meeting was modified to DEFCON 4 for Army and Air Force units.^{3/} Whereupon, at 1124 hours, CINCLANT, in a change to his earlier instructions, increased the readiness condition he had established by raising naval forces to DEFCON 3 and also the Army Civil Affairs Team

1/ (S) [] g, CINCLANT to COMJTF 122, CG CONARC, COMTAC, CINCLANTFLT, 311354Z May 61.
 2/ (S) [] M., JCS 996761 (Vice DJS sends) to CINCLANT, 311419Z, May 61
 3/ (S) [] No. to Control Division by Secy JCS, 31 May 61.

~~TOP SECRET~~

~~TOP SECRET~~

provided for in the Dominican Republic contingency plan, which was similarly placed on DEFCON 3. At the same time the respective commanders concerned were directed to prepare to execute the plan on short notice.^{1/}

INITIAL POLITICAL REACTION

38. As the prospect of possible need for military intervention in a Hurry was now threatening to become an immediate reality, the State Department planners were suddenly confronted with an urgent political problem. One of the basic terms of reference governing intervention laid down by Presidential decision at the NSC meeting of 5 May was the proviso that any action taken by the U.S. must be multilateral, a precondition that had been subsequently incorporated into the Political Contingency Plan (see above). The proposed scheme for a Caribbean Security Arrangement, with its own Caribbean Security Force, had as yet not advanced beyond the preliminary stage of tentative diplomatic moves to marshal support for the idea in principle. No specific agreements or substantive commitments had been reached. The pressing immediacy of the crisis at hand demanded emergency arrangements of an ad hoc nature in order to fulfill the "multilateral" prerequisite in time.

39. At approximately noon on the 31st, before the reported assassination of Trujillo had been confirmed, the Secretary of State sent a message to the U.S. Ambassador in Venezuela, briefing him on the substance of that part of the recently completed contingency plan for the Dominican Republic that pertained to him. The Secretary informed him that, since the events anticipated therein seemed likely, the U.S. policy objective in such circumstances was to avoid, by intervention if necessary, []

^{1/} (S) Msgs, CINCLANT to CINCLANTFLT, COMSECONDFLT (for CJTF 122), COMANTDEFCON, 311448Z May 61; 311624Z May 61.

[It also called for the United States to try to arrange for a joint declaration by the three countries regarding their interest in the Dominican situation. In order to save time, the Secretary therefore instructed the Ambassador [

] The need for caution and maximum security in this matter was stressed, because of the possibility that the reported assassination of Trujillo was a ruse in an attempted entrapment plot to compromise the U.S. ^{1/}

[40.

]

41. But to elicit concrete deeds from these abstract promises proved to be another matter. The attempt to do so constitutes a minor theme running through the history of the crisis. The intent was always there, yet somehow it never was given expression in tangible form, until eventually the whole idea became academic. (See paras. 100-109.)

1/ 2/

]

~~TOP SECRET~~

DEPLOYMENT OF FORCES

42. Meanwhile, large-scale unilateral military moves by the U.S. were under way. At 1626 hours CINCLANT advised JCS that in his command capacity "as CINCLANT/CINCLANTFLT" he had taken the following specific actions in further response to the general instructions of the Vice DJS:

a. Directed 7 destroyers to proceed to a point 20 miles [later amended on JCS orders to 40 miles for 1 DD only and 100 miles for all other surface craft] south of Ciudad Trujillo, with Estimated Time of Arrival (ETA) first light 1 June (except for 1 DD arriving 4 hours later);

b. Deployed PHIBRON 8, with a fully equipped Marine Battalion Landing Team (BLT) embarked, to the Ciudad Trujillo area (ETA 011700);

c. Deployed USS NORTHAMPTON to Guantanamo (ETA 021400) to be CJTF's flagship (CONSECONDFLT/CJTF 122 arrived at Guantanamo at 2130 hours that night);

d. Directed USS RANDOLPH, with ASW air groups aboard, to proceed to an area south of Ciudad Trujillo (ETA 011400).

He had also alerted other commanders concerned to be prepared to deploy on notice an amphibious squadron, a Marine Air Squadron, another Marine BLT (with helicopters), and the CVA's INTREPID and SHANGRI-LA.^{1/} Thus was mounted what would soon become a major operational deployment of military forces.

43. Late in the afternoon a State-Defense meeting was held to consider the political and military implications of the crisis and determine what immediate U.S. reaction was in order. The meeting amounted to an informal NSC session; attending were the Joint Chiefs of Staff, Secretary of Defense, Secretary of State, the Vice President, and the Attorney General. It was decided that the U.S. would prepare to intervene militarily, but the decision for actual landing would be held in abeyance until

^{1/} (S) Msg, CINCLANT to JCS, 312126Z, May 1961.

~~TOP SECRET~~

~~TOP SECRET~~

the internal military situation within the Dominican Republic could be determined. Direct evidence of the existence and extent of insurgent activity, and the role of the Dominican armed forces in it, was required. Therefore, an aerial photo reconnaissance mission would be conducted over the Dominican Republic. Furthermore, surveillance measures would have to be instituted to detect any possible attempt at infiltration from Cuba.

44. Following the meeting, as a result of the agreements reached, the JCS, at 1916 hours, established the following conditions of readiness for all forces earmarked to participate in the Joint Task Force for contingency operations under [] Appendix VI, Annex G (Dominican Republic): Naval units (including Marines) and the Army Civil Affairs Team on DEFCON 3; Air Force and Army units (less the Civil Affairs Team) on DEFCON 4.^{1/} The Chief of Naval Operations also alerted the Commander, Military Sea Transport Service (MSTS), to the possibility of a requirement for MSTS shipping on short notice in connection with the contingency plan.^{2/} Later, at CINCLANT's request, MSTS lift forces were earmarked and placed on DEFCON 4.^{3/}

45. At about the same time, also as a result of the agreements reached at the State-Defense meeting, JCS directed CINCLANT to take the following actions:

[a.

- 1/ (S) Msg, JCS 996815 to CINCLANT et al., 010016Z June 1961
2/ (S) Msg, CNO to COMSTS, 010145Z, June 61.
3/ (S) Msgs, CINCLANT to JCS et al., 012002Z and 012004Z June 61;
(S) Msg, CNO to COMSTS, 021925Z June 61.

c

d.



46. Many of these instructions had been anticipated and were already being put into effect prior to the formal messages directing and authorizing that they be done. Almost an hour earlier, at 1822 hours, CINCLANTFLT had informed JCS that he had ordered COMCARIBSEAFRON to establish surveillance patrols around the perimeter of the island of Hispaniola as follows: (a) a ship and air patrol in the Windward Passage; (b) air patrols by carrier aircraft, backed by destroyers, on the south coast; and (c) air patrols of the north coast. CINCLANTFLT referred in his message to JCS message 996705, date-time group 292127Z, which was more than 24 hours before the Trujillo assassination occurred. The citation was apparently erroneous, for the action taken by CINCLANT was not in response to the requirement placed by JCS therein. The message referred to was a request for information from CINCLANT regarding his estimate of what surveillance measures might be undertaken to detect possible Cuban infiltration of Haiti [sic]^{2/} In view of the anachronism and the discrepancies in content, the CINCLANTFLT action was ostensibly taken in response to instructions conveyed by other means, record of which is not available:

1/ (S) Msgs, JCS 996816 to CINCLANT, 010039Z June 61 and JCS 996818 to CINCLANT, 010212Z June 61.
2/ Msg, CINCLANTFLT to JCS, 312322Z May 61; (s) Msg, JCS 996705 (Vice DJS sends) to CINCLANT, 292127Z May 61.

~~TOP SECRET~~

or, conceivably, it could have been taken on his own command prerogative. Similarly, CINCLANT had established the identical DEFCON readiness condition for naval forces and the Army Civil Affairs Team (see above) as that designated in the JCS message, but at 1124 hours, some seven hours earlier.

ACTIVATION OF THE DOMINICAN REPUBLIC BATTLE STAFF

47. As the full military dimensions of the crisis began to emerge, the need for a special Battle Staff within the JCS organization became apparent. Hence, late in the day on the 31st a Dominican Republic Battle Staff was created. It was formally established through the instrumentality of a Director Joint Staff Memorandum (DJSM 652-61), signed, in the absence of the Director of the Joint Staff, by the Vice Director. The DJSM served as the charter prescribing the organization, mission, and functions of the Battle Staff.

48. The Dominican Republic Battle Staff was set up as an agency of the Joint Staff responsible to the Director, Joint Staff, through one of the two Deputy Directors of J-3, who was designated its Supervisor. In practice, however, during the period that the Battle Staff was in existence both Deputy Directors of J-3 shared in performing the functions of the position of Supervisor. Initially, only one Battle Staff Team was activated. It was composed of a Battle Staff Team Chief and Team Members assigned from J-2, J-3, J-4 and J-5, plus representatives, available on call, from J-1, J-6, Joint Military Assistance Affairs Division (JMAAD), Joint Programs Office (JPO), and the Joint Secretariat. Provisions were included for the activation of additional Teams if necessary, but no others were ever formed; the one Team, sufficiently augmented, proved adequate, since it was on duty fully staffed only during the day, while only a watch-officer staff was maintained at night.

~~TOP SECRET~~

~~TOP SECRET~~

49. The mission of the Battle Staff, as stated in the DJSM, was to "serve as the single Joint Staff contact point for the Dominican Republic." In such capacity, it was charged with providing briefings, information, and assistance on matters concerning the Dominican Republic situation as required. Joint Staff support of the Battle Staff would be furnished through the respective cognizant member, who would also, in turn, be responsible for presenting the views of his Directorate and obtaining its concurrence in any Battle Staff action.^{1/}

50. Most of the Battle Staff personnel came from J-3, the core of its membership formed from the Atlantic Division, which was in existence prior to the J-3 reorganization that became effective 1 July 1961. All of the J-3 members had former Battle Staff experience; three of them were always on duty during the day, when the Battle Staff was fully manned, and one of them at night to constitute the Battle Staff watch.

51. Its locus of operations was the Battle Staff Room in the Joint War Room complex, where it had the relatively sophisticated JWR communications facilities at its disposal and its own exclusive space for displays, reference materials, conferences, briefings, etc. The rationale was that the Battle Staff, as the focus of military activity and interest pertaining to the Dominican crisis, would allow for orderly and efficient management to bring to bear timely, appropriate, and concerted military action. The concept of operations was that once decisions were made, the Battle Staff would do the necessary implementing actions, for which it depended largely on delegation to action elements outside the Battle Staff itself.

1/ Memo, DJSM 652-61 to J-3 et al., 31 May 61.

52. The regular Battle Staff points of contact with the Services were the respective Service planners directly, except at night, when contact was with the Service war rooms. The point of contact with the State Department was the new Operations Control Center, and was also direct. This latter arrangement, especially, proved to be useful for achieving direct politico-military staff coordination and liaison on a practical working level.

53. In view of the magnitude and complexity of the military actions that were eventually taken in connection with the Dominican crisis, as well as the unclear nature of the situation to which they were being addressed, the Battle Staff system amply demonstrated its utility as a command and control means and process.

54. Although the Battle Staff did not become fully operational as such until the morning of 1 June, Battle Staff functions were, in effect, being performed throughout the preceding day. The JCS actions that had been taken during the 31st had had the necessary staffing support provided by the regular J-3 divisions concerned, and most of the officers involved were the ones who later became members of the Battle Staff. Thus, functionally, there was continuity represented in the transition, rather than an abrupt introduction of a totally new element when the Battle Staff was activated.

INCREASING THE FORCE COMMITMENT

TACTICAL INTELLIGENCE PROBLEMS

55. The most pressing problem confronting the Battle Staff -- and indeed the entire U.S. decision-making and implementing machinery -- was intelligence. From the very beginning, critical information as to what had happened and what was the current situation was lacking. The details of the assassination were not learned for some time, and the attendant circumstances and consequences of the event were not known with reliability until considerably later. During the first crucial days of the crisis, the very premises of decision were wanting.

b1
3

56

The Consul General's message confirming the assassination report that evening also held the same view regarding the possibility of an internal military struggle. In his opinion, although the dissidents were in hiding for the time being, the next few days would tell if the coup would succeed. ^{2/} Other than this, little more was known about the situation the first day of the crisis following the assassination.

57. From the morning of the second day, however, a mass of conflicting intelligence indications began to pour in. One of the main tasks of the Battle Staff was to interpret this confused intelligence picture and distill from it unequivocal conclusions of operational significance on which military decisions could be

b1
3

~~TOP SECRET~~
1/1
2/ (S) Msg., Ciudad Trujillo to Sec State et al., 1277, 312400Z May 61.

predicated. A commitment was required each day in the form of a succinct statement of the Dominican situation in the J-3 Dominican Republic Situation Report (Sit Rep) prepared by the Battle Staff, along with a complementary statement of the corresponding U.S. operational situation. The record of the Battle Staff's grasp of the developing situation day-by-day, as reflected in its daily Sit Reps, reveals a remarkable understanding of what the current situation actually was at the time. Compared with the deficiencies and excesses that some of the intelligence inputs occasionally manifested, its appraisals demonstrated responsible objectivity and restraint. In the main, each Sit Rep estimate of the situation, as subsequent events bore out, proved to be accurate.

58. A technical handicap under which the Battle Staff was forced to perform its intelligence interpretation function -- albeit one of no significant consequence in this instance -- was that it was denied access to CRITIC messages. Its members, except for those from J-2, were not cleared for CRITIC: clearance was eventually received after the crisis was over. The J-2 members, however, by virtue of their normal capacity as members of the Intelligence Directorate, could individually be kept apprised of pertinent CRITIC messages, and thereby were in a position to insure that no Battle Staff action was taken contrary to any CRITIC information having a material bearing on it. In practice, apparently, the other members of the Battle Staff sooner or later became cognizant of the substance of such information informally. Otherwise, there was theoretically no restriction on intelligence information made available to the Battle Staff.

61
5
59. One of the most critical single items of information was a message from Ciudad Trujillo at 0845 hours 1 June, [REDACTED]

b1
S

[situation in the Dominican Republic as of 0130 that morning. It reported that the Balaguer Government was apparently in effective control, order was being maintained, and U.S. nationals were safe. Tight security measures had been taken, with Dominican armed forces, police, and SIM (Military Intelligence Service) patrolling and guarding key points throughout the capital area. There was no evidence that democratic, pro-U.S., anti-Communist elements had achieved any influence in the Dominican Government. On the contrary, members of the actual assassination group and all associated with it were reportedly in a desperate state verging on hysteria, while the remainder of the dissidents were refraining from showing their hand.]

[As for indicated developments, it was expected that Trujillo interests would try to use President Balaguer for the time being, with some form of the Trujillo regime possibly reemerging over the immediate short term because of family wealth and position and the existing power structure.]

60. On the basis of the foregoing report, and collateral intelligence indications from other sources, the Battle Staff assessment of the situation concluded that the position of the Dominican armed forces, who could be expected to have an important effect on the outcome of the crisis, was not known. Besides official intelligence, information from open sources, such as the government-controlled Radio Caribe and the newspaper

b1
S

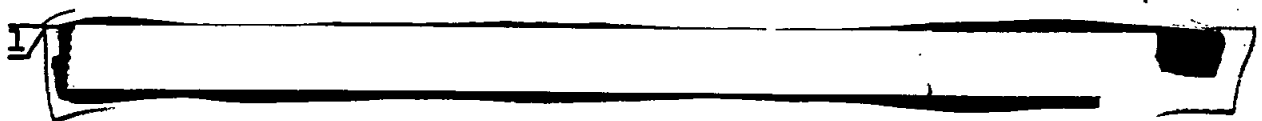

El Caribe in the Dominican Republic, as well as U.S. news media (AP, UPI, NBC News, and the New York Times), tended to corroborate that the Balaguer Government was in control and order was effectively being maintained with the help of the armed forces.^{1/} Not only was there no sign of defection or split within the military, but it appeared to be organizationally intact and loyally responsive to the existing political authority. Furthermore, General "Ramfis" Trujillo, the slain dictator's son and heir-apparent, was believed to have strong support in the Air Force ground-combat component, the major tactical element of Dominican land forces and the only one possessing armor. Finally, since Ramfis had rushed back to the Dominican Republic from abroad, it could be assumed that he did not regard the situation hostile to him.^{2/} In short, all of these indications suggested that any U.S. intervention should be prepared to meet with organized resistance by the Dominican military establishment.

61. Neither [] nor the Political Contingency Plan had expressly taken into consideration the existence of the Dominican armed forces, rated (by local standards) among the more capable defensive forces in the Caribbean area.^{3/} There was no explicit reference to the various roles they could play in relation to U.S. forces in the event of intervention, let alone provisions in specific terms for dealing with them operationally in any role. This did not reflect a tacit planning assumption that the Dominican military establishment as such should be ignored -- the question simply had not been raised. The omission only now emerged as an acute problem for military decision makers.

^{1/} (U) New York Times, pp. 1, 14, 15, 1 June 1961.
^{2/} (TS) Dominican Republic Battle Staff Sit Rep 2-61, 2 June 1961.
^{3/} (S) J-2 Appraisal of the Dominican Republic Armed Forces, 1 June 1961.

62. The validity of the conclusion regarding the internal military situation in the Dominican Republic and the attendant problem posed by the Dominican armed forces was soon further substantiated by events. As was learned later in the day, that very morning President Balaguer, meeting with the Cabinet, leaders of Congress, and the Supreme Court, issued a decree naming Ramfis to the newly created post of Head of the Joint Chiefs of Staff of the Air, Sea, and Land Forces of the Dominican Republic. At the same meeting it was also decided to continue the domestic and foreign policies followed under the late dictator.^{1/} The Dominican military establishment indeed was a factor to be considered with ~~an~~ considering any proposed intervention action against the political establishment.

DECISION TO AUGMENT FORCES

63. Thus, at the JCS meeting that morning at 1030 hours, the Battle Staff briefing emphasized the strong possibility that Dominican armed forces would vigorously oppose any action by U.S. forces in the Dominican Republic. In the light of this estimate, the JCS accordingly decided that the strength required for military intervention would have to be greatly increased over what was currently provided for in contingency plans. They agreed to revise upward the force-level commitment available for such operations by roughly doubling the total size of the combat element of the contingency force. Major augmentation of the forces originally earmarked for [] was therefore directed as follows: []

1/ (TS) Dominican Republic Battle Staff Sit Rep 2-61, 2 June 1961.
2/ Ibid.; (TS) Dominican Republic Battle Staff Log; (TS) "Talking Paper for State-JCS Meeting - 9 Jun," prepared by Dom Rep Battle Staff, 8 Jun 61.

64. While the JCS meeting was still in progress, CINCLANT sent a message to JCS recommending partial augmentation of the CJTF-122 staff with Army, Air Force, and State Department personnel. Navy and Marine Corps augmentation of the staff had already been ordered by CINCLANT, but representation of the other Services and the Department of State was required because of the joint nature of the operations contemplated and the political implications of the situation to which they would be addressed.^{1/} The implementing instructions putting into effect the JCS decision to increase the force-level commitment therefore included a response to the CINCLANT recommendation to augment the CJTF staff. A message was prepared, which after being considered by the Operations Deputies of the Services and cleared by the Vice Director Joint Staff,^{2/} was sent to CINCLANT and the Services late in the afternoon at 1759 hours.

65. The JCS approved the recommended augmentation of the CJTF staff, authorizing the military Service personnel but demurring for the time being on the State Department personnel (a Political Adviser was later designated and joined the CJTF Staff). At the same time, JCS informed CINCLANT that, in view of the "strong possibility" that the Dominican armed forces would "vigorously oppose" U.S. military intervention, a major change involving considerable increase in forces over those presently allocated under [] had been decided upon. The additional combat forces that were being made available, as agreed to in the JCS meeting and in the same general terms, were then listed. CINCLANT was directed to revise as a matter of urgency his contingency plans accordingly and to submit requirements for yet additional combat and support units that undoubtedly would be

1/ (S) Msg, CINCLANT to JCS, 011552Z, Jun 61.
2/ (TS) JCS Dominican Republic Battle Staff Log.

~~TOP SECRET~~

needed as a result of the increase, in order to provide a balanced force. He was also instructed that air supremacy had to be established prior to the assault and maintained during the assault and subsequent combat phases of the operation. Other action-addressees to whom the message was sent, inasmuch as its provisions affected them directly, were the Service chiefs, namely, the Chief of Staff Army, Chief of Staff Air Force, Chief of Naval Operations, and Commandant Marine Corps. ^{1/}

66. In response to the requirement laid on and in accordance with the authorization granted in the JCS message above, CINCLANT, at 2358 hours, informed CG CONARC, COMTAC, and CJTF 122 of the changes necessary to the basic Dominican Republic contingency plan contained in [] They were requested to modify the general section of the existing plan by adding the following operational assumption regarding the enemy force: "Dominican Military Forces will vigorously oppose U.S. intervention." To carry out the JCS-directed augmentation of forces, CINCLANT requested them to amend specified portions of the plan as follows:

a.

b.

]

^{1/} (TS) Msg JCS 996876 to CINCLANT, CS, CNO, CSAF, and CMC, 012259Z, Jun 61.

~~TOP SECRET~~

~~TOP SECRET~~

c.

7

67. A measure of the extent of planning revision that these changes entailed is indicated by the length of time it took to revise the supporting Service plans and the various unit plans subordinate to them. Not before 9 June was CINCLANT able to report to JCS that the revisions, although as yet incomplete, had progressed sufficiently to permit execution of the modified contingency plan for the Dominican Republic by 10 June. Completion of the detailed planning was not expected until approximately 17 June, and CINCLANT cautioned that execution of the modified plan earlier than that date would involve some risks in resupply support.^{2/} The time lag between the initial JCS decision to augment the force-level commitment and the implementation of the decision -- though only in the form of completed planning revisions at that -- suggests the ramifications of such a decision if it were to be given expression in real terms. During the course of these revisions the complexity of the planning readjustments that were involved even necessitated the presence of two J-3 members of the Battle Staff on 3-4 June at CINCLANT Headquarters in Norfolk.^{3/} The point demonstrated is

1/ (TS) Msg, CINCLANT to CGCONARC, COMTAC, CJTF 122, 020458Z Jun 61
2/ (S) Msg, CINCLANT to JCS, 091624Z Jun 61.
3/ (TS) JCS Dominican Republic Battle Staff Log.

that the time required for planning/coordination is one of the inherent institutional constraints upon flexibility of operational decisions.

POSITIONING OF FORCES

68. While these planning revisions to augment the forces for [] were getting under way, CINCLANT was confronted with immediate operational considerations in connection with deploying the forces already at his disposal. Desiring to have them tactically situated to optimum advantage should immediate execution of the contingency plan be ordered on moment's notice, he felt the JCS-imposed restriction on proximity to the target area would seriously affect the speed of response in carrying out such an order. That afternoon he requested JCS to modify their previous instructions so as to permit the approach of CINCLANT forces to positions closer than 100 miles from the Dominican coastline, but out of sight of land, in order to improve reaction potential.^{1/} The JCS took up the matter with the Secretary of Defense, including it in a memorandum devoted primarily to a larger proposal for a politico-military course of action designed to resolve favorably the entire crisis.

69. In the memorandum to the Secretary of Defense, the JCS "strongly recommended" that, in view of no pro-U.S. moderate dissident group having asserted itself, the U.S. actively seek out such a group, assure it of U.S. support, and urge it to declare itself as constituting the provisional government of the Dominican Republic. Then, upon receipt of a request for assistance from that group, the U.S. would immediately employ the necessary force to establish the new government. To this end, it

1/ (S) Msg, CINCLANT to JCS, 012058Z Jun 61.

~~TOP SECRET~~

was therefore also recommended that the positioning of CINCLANT forces in the vicinity of the area where they would be employed be immediately authorized in order that they be advantageously located for suitable reaction. The JCS urgently requested that these recommendations be discussed with the Secretary of State as soon as possible.^{1/}

70. A State-Defense meeting, attended by the Vice Director Joint Staff, was held to consider the JCS recommendations above. The main portion of the proposal was referred by the State Department to the President in Europe. Approval was granted, however, for closer positioning of forces already in the general target area. At 1943 hours, JCS, with the concurrence of the Secretary of Defense, authorized CINCLANT to reduce ships' distance from shore to not less than 50 miles.^{2/} This was later amended even further, allowing deployment of more forces into the area and permitting approaches nearer to Dominican territory. The available record does not reveal whether the main substance of the JCS-proposed strategic course of action was formally acted upon in terms of a Presidential decision being rendered, but shortly the issue was to be rendered academic by events when developments clearly made some of the basic premises on which the feasibility of the proposal depended no longer valid.

^{1/} (TS) Memo, CJCSM-379 to Sec Def, "Current Action-Dominican Republic," 1 Jun 61.

^{2/} (TS) Msg, JCS 996883 to CINCLANT, 020043Z Jun 61; (TS) JCS Dominican Republic Log; (TS) "Talking Paper for State-JCS Meeting - 9 Jun," prepared by JCS Dominican Republic Battle Staff, 8 June 61.

~~TOP SECRET~~

THE INTELLIGENCE DILEMMA

INDICATIONS AND CONTRA-INDICATIONS

b1
5

71. Through the remainder of the day (1 June) the intelligence picture of the situation within the Dominican Republic did not improve much. [REDACTED] In fact, rather than being clarified by the greater volume of intelligence inputs, it deteriorated somewhat. Conflicting indications, outright contradictions, omissions, and misleading information not only kept the picture out of focus and distorted its perspective, but the resulting ambiguity tended to refract it into an irreconcilable double image.

72. On the one hand, reports came in indicating that the insurrection was successfully gaining momentum. General Estrella, one of the dissident leaders most acceptable to the U.S. and a member of the activist group involved in the assassination of Trujillo, was reported in control of the northeastern area of the Dominican Republic, while General Diaz, another participant in the assassination plot, was supposed to be in the west defended by 1,000 troops. It was also reported that guerrillas in the Cibao Mountains were prepared to support a move to seize power from the Trujillo family.^{1/}

73. On the other hand, reports came in indicating possible failure of the coup attempt. There had been no sign as yet of a palace revolt. On the contrary, the functional integrity of the various organs of state appeared to be unimpaired, and the government's security and military forces seemed determined to suppress any opposition to the existing regime. As a consequence the dissidents in the Ciudad Trujillo area, according to the

1/ (C) Msg, Ciudad Trujillo to Sec State, 1280, 011600Z Jun 61.

~~TOP SECRET~~

Consul General, were in a serious plight. They were fearful for their lives lest they be caught up in the sweeping retaliatory campaign reportedly being ruthlessly waged against them by elements representing Ramfis and the insidious Lt. Col. Abbes, head of SIM; those who were not in hiding were looking to the U.S. for sanctuary or help in escaping. Although the Consul General reassured the Secretary of State that the dissidents were fully aware of the formula for requesting U.S. assistance if they could establish a plausible provisional government, he was apprehensive about what would happen to them if they did so.^{1/} He was equally concerned about the consequences for American nationals. Therefore, in anticipation of possible extremes to which initial Trujilloist reaction to U.S. intervention might go, he proposed certain preemptive measures to be taken in the event a decision were made to land Marines. In a message to the Secretary of State late that night, he recommended that one of the first tactical objectives be the seizing of the Hotel El Embajador in Ciudad Trujillo, if necessary by helicopter prior to the amphibious assault, in order to preclude Ramfis-Abbes forces from holding as hostages the many U.S. citizens residing there. Other priority objectives also recommended for consideration were the National Palace, SIM Headquarters, La Victoria Prison, and the notorious interrogation center La Cuarenta, in order to save the lives of political prisoners who might otherwise be summarily killed and to obtain information to compromise the regime.^{2/} A copy of the message containing the Consul General's recommendations was forwarded without comment to CINCLANT two days later by the Vice Director Joint Staff, to whom it had been referred by the State Department.^{3/}

- ^{1/} (S) Msgs, Ciudad Trujillo to Sec State, 1283, 011700Z, and 1286, 011800Z Jun 61.
^{2/} (TS) Msg, Ciudad Trujillo to Sec State, 1290, 020500Z Jun 61.
^{3/} (TS) Msg, JCS (V DJS sends) to CINCLANT, 032121Z Jun 61.

~~TOP SECRET~~

~~TOP SECRET~~

74. To exacerbate further the intelligence confusion, there were also reports received during the day indicating a possibility of direct interference from Cuba and the USSR. Naval Intelligence relayed information that pro-Communist/pro-Castro Dominican exiles in Cuba, allegedly recruited and trained expressly for the purpose, were supposed to be in the process of preparing for an imminent invasion of the Dominican Republic.^{1/} Moreover, ship-contact reports coming in as a result of the surveillance procedures instituted the day before identified several Soviet and other foreign vessels proceeding in waters adjacent to the Dominican Republic coastline. These and subsequent ship contacts were kept under air surveillance and shadowed by Naval surface craft, but none proved to be actually bound for destinations in Dominican territory.^{2/} At the time, however, in the context of the contemporary intelligence picture and in view of the long U.S. policy preoccupation with the fear of Castro/Communist exploitation of the crisis, such indications as these were, in the absence of contraindications, of major concern and received Battle Staff attention accordingly.^{3/}

75. Great importance had been attached to the aerial photo-reconnaissance mission to be flown over Dominican territory at first light on the morning of 1 June: it was counted on to produce definitive, unequivocal evidence of what was actually happening militarily. Special procedures had, in fact, been established for handling the reconnaissance photographs and photo-interpretation reports. The arrangement called for them to be rushed by air to Washington and delivered to the Secretary of Defense in person and to Mr. Goodwin in the White House and the

^{1/} (C) Msg, DIO 10 ND to CNO, 012359Z Jun 61.
^{2/} (C) Msg, CTU 81.7.9 to COMFLTRAGRU Guantanamo, 012153Z Jun 61.
^{3/} (TS) JCS Dominican Republic Battle Staff Log.

~~TOP SECRET~~

Director of the Operations Center at the State Department. The results of the mission, however, were inconclusive. No indications of unusual military activity in the Santiago and Cibao areas were revealed, but owing to dense cloud cover, effective photoreconnaissance of the Ciudad Trujillo area had not been possible. Nevertheless, the results were delivered as pre-arranged. Because of the unfavorable weather conditions during the first mission, a second mission the next day (first light 2 June) was authorized, with State and White House approval, and the same procedures were followed in handling the results as the previous day. Complete coverage was obtained this time and the results revealed no unusual activity of military significance in either the Ciudad Trujillo or other areas.^{1/} Nevertheless, unconfirmed reports of large-scale military engagements between dissidents and Government forces persisted for some time longer, but no further reconnaissance missions were flown over Dominican territory during the crisis.^{2/}

76. By the end of the day of 1 June, despite many specific details of the intelligence picture being still undefined, certain general configurations of the crisis were beginning to emerge. Reflecting a partial concession to these as yet inconclusive observations, a tentative change in the U.S. political appreciation of the Dominican situation became evident, and concomitant with it, the incipient beginnings of a significant change in U.S. policy posture.

77. Late in the evening a State Department circular telegram was issued to all U.S. diplomatic posts in Latin America, which summarized the nature of the crisis and the U.S. position toward

^{1/} (TS) JCS Dominican Republic Battle Staff Log; (S) Msgs, VAP 62 to CINCLANTFLT, 020113Z and 022255Z Jun 61; (S) Msgs, LANTINCEN to CINCLANTFLT, 030702Z Jun 61.

^{2/} (TS) JCS Dominican Republic Battle Staff Log.

~~TOP SECRET~~

~~TOP SECRET~~

it, and outlined the national objectives and policies pertaining thereto. Of greatest substantive import was the part that addressed itself to the future internal political situation within the Dominican Republic. It stated that the U.S. attitude toward any new government would depend on the degree to which it moved to disassociate itself from the Trujillo past and its stand on Communism and Castro. Further, the U.S. was prepared to accept a coalition government composed of pro-U.S. moderate civilians and acceptable military elements, not excluding the possibility of Balaguer himself remaining on as President. Addressees accordingly were instructed to avoid any criticism of the Balaguer Government. Conspicuously, there was no mention of the dissidents.^{1/}

78. The circular telegram heralded a fundamental departure toward a new direction from a long-prevailing course of policy to which the U.S. had been firmly committed politically and militarily, in plans and actions, for over a year. The momentum of the earlier policy commitment to install a dissident-formed government continued, however, to exert a force in opposition to the evolving new policy for some time longer, with the military view tending to adhere to the former and the political to incline toward the latter, until gradually the new policy predominated and displaced the old. In the interim, before a concensus was restored, two seemingly dichotomous policies were manifest in U.S. actions of the next few days: on the one hand, preparing for military intervention; on the other, seeking for a nonmilitary solution. It was in large part the absence of reliable political intelligence that delayed the final choice of one over the other.

1/ (S) Msg, State Circular 1917, 020202Z June 1961.

OVERESTIMATING THE SITUATION

79. Through the course of the day of 2 June the pattern of intelligence indications clarified to the extent of revealing trends in the development of the internal situation in the Dominican Republic. The nature of the trends was interpreted correctly enough, but the evaluation of their intensity, as viewed locally and reported from the scene, proved to be in error.

80. Very early in the morning the U.S. Consul General described a situation developing that injected a new factor into the crisis as far as U.S. policy was concerned. Not only was control by the Trujillo faction apparently uncontested, but dissidents were now at the mercy of Trujilloist retaliation. According to the Consul General, a reign of terror that could reach blood-bath proportions was getting under way, with "real slaughter" probably imminent following the Benefactor's funeral. Members of opposition groups -- and some Americans -- were frantic with fear and had appealed to him for immediate U.S. intervention on any excuse. In answer to their appeal, he had instructed representatives of the dissidents to obtain from their leaders a formal written request for such U.S. assistance. Meanwhile, he urgently recommended dramatic action by the U.S., in conjunction with other Latin American nations or the OAS, to prevail upon the Balaguer-Ramfis regime to moderate its policies toward the political opposition.^{1/}

81. At noon the Consul General, in another message, advised the Secretary of State that as a precautionary measure, in anticipation of the internal situation worsening, he had put Phase II of his security plan into effect, but that he would not order

1/ (S) Msg, Ciudad Trujillo to Sec State, 1289, 020600Z June 61.

the evacuation of Americans because he felt to do so would only provoke the Government into taking reprisals and might even draw an attack on the Consulate.^{1/} An hour later the Consul General advised that, because of the likelihood of attacks on American personnel, he had authorized arrangements for families of the Consulate Staff, who so desired, to be evacuated to Puerto Rico on a voluntary basis and at the expense of the individuals concerned.^{2/} Only a handful chose to leave.

82. Early that evening at 1900 hours, the Military Assistant to the President telephoned the Director of the Joint Staff to inform him that the White House Situation Room was in receipt of a message, relayed by the State Department from the Consul General in Ciudad Trujillo, to the effect that the U.S. Consulate was burning its papers in expectation of an attack. The DJS instructed the Battle Staff to determine if any information along these lines had been received in the Joint War Room or elsewhere. When a check with the Joint War Room, J-2, the Service War Rooms, and the State Department revealed no record of such a message, a messenger was sent to the White House to pick up a copy of the message in question. Upon examination, the message that the Presidential Military Assistant had reference to proved to be message number 1293 from Ciudad Trujillo to the Secretary of State, DTG 021700Z June 1961 (see above), which had been duly received and noted by all concerned some five or six hours earlier. The belated alarm was apparently a case of the manifest purport of the message, as well as its implications, being misinterpreted.^{3/} Once the mistake was recognized, the matter was dropped.

- ^{1/} (S) Msg, Ciudad Trujillo to Sec State, 1293, 021700Z, Jun 61.
^{2/} (C) Msg, Ciudad Trujillo to Sec State, 1296, 021800Z, Jun 61.
^{3/} (TS) JCS Dominican Republic Battle Staff Log; (S) Msg, Ciudad Trujillo to Sec State, 1293, 021700Z Jun 61.

83. Shortly before midnight the Consul General submitted an appraisal of the general political situation in the Dominican Republic. He reported that the Balaguer Government had the same policies and personnel as the former Trujillo Government, with the most objectionable faction of the Trujilloists in control.

b1
4

[] The Consul General further stated that there were no credible indications of an ameliorating transition from terrorism and police-state methods toward moderation, nor any sign of conciliation with the opposition. He also reaffirmed his earlier reports of dissidents being panic stricken over the Government's campaign of arbitrary and indiscriminate reprisal. He discounted reports that the dissidents were effectively in control of any part of the country. Nor did he believe there was evidence of anything approaching a plausible provisional government having been formed by the dissidents, although he felt one would quickly emerge if fear of the existing Ramfis/Abbes-controlled Government could be removed.^{2/}

84. In sum, throughout the day the Consul General, who was the Chief source of intelligence on the Dominican internal situation, had portrayed a state of affairs urgently demanding outside intercession. Contrary to what had been anticipated in U.S. planning, however, the pressing need of the moment was not to insure enterprising dissidents an opportunity to seize power from a weak post-Trujillo regime, but to rescue the helpless dissidents from the wanton ferocity of a too-powerful regime.

85. The immediate U.S. policy response to these reported conditions was political. Steps were taken from two different

b1
5

1/ [redacted]
2/ (S) Msg, Ciudad Trujillo to Sec State, 1303, 030400Z Jun 61.

directions to bring international pressure to bear upon the Dominican Government to moderate its policies: on the one hand, official OAS action was sought; on the other, diplomatic persuasion by individual countries. The U.S. urgently requested the Organization of American States (OAS) to send observers into the Dominican Republic as soon as possible in the hope their presence would discourage the reign of terror.^{1/} At the same time, all U.S. diplomatic posts in Latin America were instructed to inquire of the respective governments to which each was accredited whether they had similar knowledge of terrorism in the Dominican Republic, and if so, to recommend that they request their missions in Ciudad Trujillo to urge restraint upon the Dominican Government. The following day this was expanded in an effort to marshal all Free World opinion to support this new U.S. position toward the Dominican situation. U.S. Ambassadors in selected pro-Western countries outside the Western Hemisphere were instructed to approach the respective Foreign Offices of the governments to which they were accredited and try to obtain confirmation of the U.S. appraisal of terrorism in the Dominican Republic, as well as recommendations regarding indicated courses of action to relieve the situation.^{2/}

86. On both counts the attempt to arouse international interest in and support for the U.S. position on the Dominican problem proved a complete failure. As will be seen later (see par. 146), the bilateral approach with individual countries found none of the governments agreeing with the U.S. appraisal of the Dominican internal situation. Similarly, the results of the formal approach through the agency of the OAS, the details of which will also be presented in context later in the study (see paras. 225-228, and 237), proved no more successful.

^{1/} (U) New York Times, 6 Jun 61, pp. 1,3.

^{2/} (S) Msg, Sec State Circular (to all U.S. diplomatic posts in Latin America), 1929, 022300Z Jun 61. (C) Msg, Sec State to Ciudad Trujillo and Circular 1939, 3 Jun 61.

MILITARY READINESS BUILD-UP

87. Despite the strategic intelligence problem as to the nature of the crisis situation, the military build-up that was set in motion on 1 June by the decision to augment forces reached full stride the following day. To increase immediate readiness posture, the JCS, with the concurrence of the White House and the Secretary of Defense, on 2 June directed more forces to be moved into the area of potential operations. CINCLANT was instructed to sail two CVA's (aircraft carriers) and the remainder of the 4th Marine Expeditionary Brigade (the command-administrative organization embracing the various Marine elements participating in the contingency plan) from the U.S. to the Caribbean area. That same afternoon the aircraft carriers INTREPID and SHANGRI-LA, along with 4 destroyers and auxiliary ships, departed East Coast ports for Caribbean destinations, while Marine lift vessels of the naval amphibious group began to prepare for loading of the Marine units.^{1/}

88. While the main focus of operational interest was the Dominican Republic, precautionary attention also had to be given to Haiti, the contiguous neighbor occupying the western third of the island of Hispaniola. Long considered a potential trouble spot, it was now particularly exposed to the disturbing currents revolving around the Dominican crisis. The State Department, therefore, desired U.S. military presence in the area in order to help stabilize the Haitian situation, as well as to provide increased reporting capability by having reliable communications on hand locally. The JCS agreed, and the U.S. Ambassador in Port-au-Prince was instructed to approach the Haitian Government and make arrangements

^{1/} (TS) Msg, JCS 996895 to CINCLANT, CSA, CMC, CNO, CSAF, 021501Z Jun 61; (TS) JCS Dominican Republic Battle Staff Log; (TS) J-3 Dominican Republic Sit Rep 2-61, 2 Jun 61.

for a visit by two U.S. destroyers. Permission was granted by the President of Haiti for a weekend visit, with the understanding that the period might be extended if needed, for one destroyer each at Port-au-Prince and Cap-Haitien.^{1/} The situation was reported to be "completely calm," with the Haitian-Dominican border normal and no unusual military activity noted, and so it remained throughout the crisis.^{2/}

89. In view of the mounting scale and expanding scope of naval activity, a technical impediment potentially affecting flexibility of deployment also became apparent on 2 June, one that might seriously inconvenience operations once the contingency plan was implemented. This was the legal problem of passage clearance to enter or traverse waters under foreign jurisdiction. A standing arrangement already existed with the United Kingdom with respect to U.S. naval vessels in the British West Indies, whereby clearance could be obtained locally with the British Naval Commander. A similar arrangement was now desirable with respect to territorial waters of the Netherlands in the Caribbean area. The Netherlands Government was therefore requested that afternoon, through the U.S. Ambassador at The Hague, for permission to clear movements of U.S. naval vessels in waters under Netherlands jurisdiction directly through the Naval Commander of the Netherlands Antilles, in order to avoid the delay of being forced in each case to go through formal diplomatic channels.^{3/} Permission was readily granted but, as matters turned out, the U.S. had little occasion to avail itself of the privilege. It could, however, have significantly aided speed and freedom of action in actual operations, especially had Venezuelan naval units participated with U.S. forces.

^{1/} (TS) J-3 Dominican Republic Sit Rep 2-61, 2 Jun 61; (C) Msg, Port-au-Prince to Sec State, 408, 021700Z Jun 61; (C) Msg, CNO to CINCLANTFLT, 021805Z Jun 61.

^{2/} (C) Msg, Port-au-Prince to Sec State, 400, 021700Z Jun 61; (C) Msg, USARMA Port-au-Prince to D/A and CGUSARCARI, CX-20, 022001Z Jun 61.

^{3/} (C) Msg, Sec State to The Hague (G-87) and Curacao (G-04), 2 Jun 61.

90. By late afternoon of 2 June JTF 122 force deployment status, as reported by CINCLANT in an operational situation summary submitted to JCS, was as follows:

a. CJTF 122 (COMSECONDFLT) was aboard his flagship NORTHAMPTON in the vicinity of Guantanamo.

b.

c.

(1)

(2)

(3)

(4)

(5)

d.

e.

1/7

91. The deployment schedule was accelerated somewhat a few hour later when CINCLANT ordered units of PHIBRON 2 and PHIBRON 10 to

1/ (S) Msg, CINCLANT to JCS, 022211Z Jun 61.

~~TOP SECRET~~

sail independently as fast as they were loaded. The estimated time of arrival in the Caribbean area of the first units, including BOXER, was accordingly changed to 6 June.^{1/}

92. Shortly before midnight CINCLANT's Operations Officer called the Battle Staff and informed them tentatively of a proposed course of action. He recommended that, if permission could be obtained, it would be desirable at that time to make a show of force by moving Task Force 44.9 closer to the Dominican Republic coast than 50 miles, but outside the three-mile limit, so as to be within sight of land. In view of the decision time delay that could be expected, since authorization for such a move would have to come from a high level, he planned to recommend to CINCLANT that this action be undertaken immediately, before a decision was rendered. If the authorization were denied, the force could be recalled at any time within 2½ hours and "no one will be the wiser." The matter was referred to the Director Joint Staff, who turned it down. In the meantime CINCLANT himself had rejected the proposal, stating that no such action would be taken unless directed by JCS.^{2/}

93. The episode marked an early manifestation of what was to be a characteristic role of the Navy in attempting to influence national decision making during the crisis from the operations/implementation level upward. It progressively became the advocate of a forthright military solution to the crisis. COMSECONDFLT, the tactical commander of deployed U.S. forces, especially became sanguine in this regard, repeatedly urging a decision to make use of the military forces at his disposal. Being most directly involved in the partial U.S. commitment represented by deploying of forces, he was the one to opt most aggressively for

^{1/} (S) Msg, CINCLANT to JCS, 030548Z.

^{2/} (TS) JCS Dominican Republic Battle Staff Log.

~~TOP SECRET~~

full commitment in following through the momentum of the course of action started upon by actually utilizing the military capability of those forces. The pattern suggests a hypothesis concerning a regenerative feedback effect of commitment in the decision-implementation interrelationship: the greater the degree of commitment, the greater the tendency for self-intensification of that commitment.

~~TOP SECRET~~

REQUEST FOR U.S. INTERVENTION

94. In the midst of the gradually developing intelligence picture during 2 June, as seen and reported by the Consul General, there occurred one of the critical incidents of the crisis. Late in the afternoon, as a direct result of the Consul General's earlier instructions to representatives of the dissidents to obtain a written request for military assistance (see par. 80 above), such a formal request for U.S. military intervention was finally received. At 1700 hours the Consul General transmitted the text of a letter delivered to him personally from General Estrella, a dissident leader considered politically acceptable to the U.S. In the letter, General Estrella formally asked in the name of the Dominican armed forces that the U.S., acting with other Latin American countries through the OAS, urgently send land, naval, and air forces to the Dominican Republic to assist in maintaining public order and preventing foreign intervention, so that democracy might be established by means of free elections. He promised to support a democratic provisional government oriented to the West and committed to holding free elections. The letter was deemed to be authentic by the Consul General, and the request it contained, bona fide.^{1/}

95. Receipt of the long-awaited formal request for U.S. help seemingly met one of the crucial conditions prerequisite to military intervention that had been laid down by the NSC and reiterated in all subsequent political planning and policy. The immediate reaction in Washington was a special meeting called for 2330 hours by the Acting Secretary of State, with the Secretary of Defense, the Chairman of the Joint Chiefs of Staff,

^{1/} (S) Msg, Ciudad Trujillo to State Department for OSD, DA, CNO, DEPTAF, 1298, 022400Z Jun 61; Msg, Ciudad Trujillo to Sec State, 1301, 030300Z Jun 61.

and other members of the Government attending, to consider the request and determine what the U.S. response should be. At the meeting there was much discussion of the political implications involved, for now that the all-important request was in hand, neither it nor the surrounding circumstances were as unequivocally explicit as the crisply defined model postulated in planning assumptions. Instead, the actual event was fraught with ambiguity.

96. In the first place, the source of the request did not meet the cardinal requirement of constituting a "plausible provisional government." Secondly, there was no evidence that any dissident group met the requirement of a credible claim to control over any part of Dominican territory. Furthermore, one of the basic terms of reference prescribed as a condition of U.S. intervention was that any such military action would have to be multilateral. So far, all that had been achieved in this regard was the original agreement in principle; to make the necessary diplomatic and technical arrangements for operational participation by other forces, even if feasible, would involve long delays. Finally, there was the growing body of intelligence indications beginning to suggest that the strength and character of the dissident movement had been grossly overestimated; rather than an effectively organized and led group with a broad base of popular support, it was more likely a small, amorphous and politically inarticulate scattering of individuals. All of these considerations tended to vitiate the request.

97. The outcome of the deliberations, after lengthy review of the various factors bearing upon the issues raised by the request, was that no concrete course of action was decided upon at the meeting. It was not a case of rejecting the request, but simply a matter of leaving it in abeyance pending further developments. Even such contingent preparations as positioning of deployed

forces was kept unchanged, with the proximity of naval units held to the previously set 50-mile limit.^{1/} In effect, however, a de facto decision was thereby made, namely, not to respond to the request at that time, in the present circumstances. Although it was not realized at the time, this was the turning point of the crisis. There was to be no other formal request for intervention.

98. The State Department nevertheless followed up the Estrella request to the extent of asking, the next day, for the Consul General's estimate of the "probability" of the Estrella group being able to constitute itself into a plausible provisional government on its own initiative and responsibility, now or in the foreseeable future.^{2/} The Consul General's reply stated that, under the prevailing conditions of terror and repression, "the answer is no," but if the Dominican Government allowed freedom, "then yes."^{3/} As matters turned out, there never was even a question of probability involved (see paras. 203 and 204).

99. Thus was eliminated, as was only later perceived, a decision alternative. Both an eventuality and the course of action addressed to it had been ruled out by events.

^{1/} (TS) JCS Dominican Republic Battle Staff Log.
^{2/} (S) Msg, Sec State to Ciudad Trujillo, 771, 3 Jun 61.
^{3/} (S) Msg, Ciudad Trujillo to Sec State, 1315, 040300Z Jun 61.

OPERATIONAL PROBLEMSMULTILATERAL COORDINATION

100. Meanwhile, quite independently of the Estrella letter incident, attention was being given to the matter of multilateral action. The negotiations begun earlier with Venezuela and Colombia which had resulted only in diplomatic expressions of agreement in principle, were now stepped up in pace, intensity, and specificity, in an effort to translate the as yet undefined political commitment into practical military terms. The complex problems involved in trying to arrange all of the necessary technical details on the level of operational reality were further complicated by mutual policy sensitivity to the political ramifications implicit in such technical arrangements. As a consequence, the specific negotiations on concrete issues were characterized by an attitude of caution on both sides, with the respective authorities of each reluctant to make concessions, commit themselves, or divulge information.

101. It was on the morning of 2 June that authorization was granted by the President of Venezuela for technical coordination between Venezuelan and U.S. military representatives. The U.S. Naval Attache in Caracas, who would be the one most directly concerned, had immediately requested guidance for his discussions with Venezuelan naval authorities, in view of the fuel, supply, equipment, and maintenance problems of the Venezuelan Navy. The whole question of terms of reference, however, was taken up from a larger perspective by JCS. That afternoon the JCS, in a message cleared by the Chairman, directed that U.S. military missions in Caracas participating in technical discussions were to make no U.S. commitments to the Venezuelans. At the same time, CINCARIB was instructed to obtain and forward all available

I/ (TS) Msg, ALUSNA Caracas to ONI, 021630Z Jun 61.

information on Venezuelan plans for military actions to be taken in conjunction with parallel U.S. military actions, including concept of operations, size and types of forces to be employed, command relationships, and other important facts.^{1/} This information was needed to determine how best the operational coordination of joint U.S.-Venezuelan efforts could be facilitated.

102. Under the impetus of the Estrella request for intervention, urgent discussions were undertaken the next day (3 June), beginning with a meeting between the U.S. Ambassador and the Chiefs of the Venezuelan armed forces. But other than general promises to cooperate and make available Venezuelan ships, planes, and troops, the only explicit result of substance was the disclosure that four Venezuelan destroyers were scheduled to leave port that day to stand by at sea ready for use when and as ordered.^{2/} Even this last statement, as will be seen shortly, could not be completely verified by the U.S. for the duration of the crisis. Little success was had in obtaining much further information on Venezuelan military activities.

103. The lack of pertinent basic information was especially acute for CINCLANT, who had the responsibility for operational planning for whatever multilateral military action there would be. On 5 Jun CINCLANT therefore requested JCS to provide guidance for planning for the employment of Latin American forces, particularly those of Venezuela, in support of his contingency plan for the Dominican Republic in [] Terms of reference were needed regarding command arrangements, forces, logistics, and liaison. He recommended that agreements be sought with the respective governments concerned for all such forces to be under the operational control of the U.S. Joint Task Force Commander

1/ (TS) Msg, JCS 995976 to CINCARIB (info CINCLANT), 022248Z Jun 61.

2/ (TS) Msg, Caracas to Sec State, 1191, 032000Z Jun 61.

(CJTF 122), who would function in the capacity of either OAS Commander or bilateral Combined Commander. He also recommended that there be included in these agreements a determination of the amount and kind of forces each country would contribute, capabilities of these forces, time phasing of their availability, and U.S. logistic support required. Finally, the agreements should arrange for liaison officers between forces.^{1/}

104. Before the JCS could respond, CINCARIB responded the next day (6 June) to JCS's earlier request of 2 June for information regarding Venezuelan plans (see above). CINCARIB advised JCS that none of the requested information were available. U.S. military missions in Venezuela had been unable to gain any knowledge of Venezuelan operational plans, thus could not furnish the planning information specified. Attempts would continue to be made, however, to obtain the information indirectly. To this end the U.S. Ambassador in Caracas was formally offering the services of the U.S. military missions in Venezuela to the President and Minister of Defense as advisors for operational planning.^{2/} This approach too failed, and the Venezuelans never did request planning help of the local U.S. military missions or attaches.

105. Two days later the question of eliciting planning information to coordinate multilateral military action was rendered largely academic, when on 8 June the JCS responded to both CINCLANT's and CINCARIB's messages above. The JCS advised them that for the time being no firm guidance in the employment of Latin American forces could be provided, inasmuch as the U.S. Government's policy toward the new regime in the Dominican Republic was not yet

^{1/} (TS) Msg, CINCLANT to JCS, 052030Z Jun 61.

^{2/} (S) Msg, CINCARIB to JCS, CC 68275A, 061659Z Jun 61.

~~TOP SECRET~~

sufficiently established.^{1/} In point of fact, by this date developments in the Dominican situation clearly indicated an increasing likelihood of eventual political resolution of the crisis and less probability of need to resort to military action from outside.

106. Attempts continued to be made, however, to obtain technical information on any current military operational activities being undertaken by Venezuela and Colombia unilaterally that were related to the Dominican crisis. As in the case of information regarding plans, these efforts by the U.S. to apprise itself of what its contemplated partners might be doing on their own met a similar impasse, thereby posing what amounted to an added intelligence burden for the U.S. It will be recalled that on 3 June the Chiefs of the Venezuelan armed forces had stated to the U.S. Ambassador, without divulging details, that four Venezuelan destroyers were being deployed to sea to stand by ready for use if needed (see above). Then on 6 June the President of Venezuela arranged for a "leak to the press" that a division of Venezuelan destroyers was on its way to Dominican waters and that the Venezuelan Air Force was on 24-hour alert. But U.S. military missions in Caracas were unable to confirm if such actions had actually been taken.^{2/}

107. The following day (7 June) COMSECONDFLT/CJTF 122, being the one most directly affected by deployment of Venezuelan forces into the Dominican area of operations, inquired of JCS if Venezuelan naval units were indeed proceeding to the vicinity of the Dominican Republic as reported, and if so, what their estimated time of arrival would be.^{3/}

^{1/} (TS) Msg, JCS 997207 to CINCLANT and CINCARIB, 080017Z Jun 61.

^{2/} (S) Msg, ALUSNA Caracas to CNO, 062230Z Jun 61.

^{3/} (S) Msg, CONESCONDFLT to JCS et al., 071457Z Jun 61.

~~TOP SECRET~~

The query was referred to the State Department, and the Secretary of State in turn instructed the U.S. Ambassador in Caracas to find out.^{1/} The next day (8 June) the Venezuelan Government disclosed to the Ambassador that joint Venezuelan-Colombian fleet maneuvers were to be held in the vicinity of the Dominican Republic. These maneuvers were originally to have taken place between 18 and 25 June, but the schedule had been advanced so as to begin immediately, and they would continue as long as necessary. The official orders authorizing the maneuvers, which had been shown to the Ambassador, revealed that three Venezuelan destroyers would be involved, while Colombia would contribute two destroyers and one frigate. The Ambassador advised that extensive supply support by the U.S. Navy would be required and expected.^{2/} By this time (9 June), however, the military phase of the crisis was to all practical purposes over, and the information, even if accurate, an anticlimax.

108. Until the whole question of Venezuelan naval activity was overtaken by events and no longer operationally relevant, the U.S. had been unable to determine whether the three or four Venezuelan destroyers referred to were indeed ever intended for any operational role addressed to the Dominican crisis. Of the various Venezuelan naval vessels that did leave port, it was learned that the ultimate destination of three destroyers that sailed with skeleton crews was actually Leghorn, Italy, where they had been scheduled to undergo much-needed overhaul. One U.S. interpretation was that conceivably these three vessels, while under way, had been incidentally diverted from their course so as to pass in the general vicinity of the Dominican Republic and thus

^{1/} (S) Msg, Sec State to Caracas, 1197, 3 June 61.
^{2/} (S) Msg, Caracas to Sec State, 1236, 082200Z June 61.

lend credence to claims of Venezuelan naval forces being present in the crisis area.^{1/} As for the "joint Venezuelan-Colombian fleet maneuvers," the sources available to this study do not reveal any pertinent details, nor whether they ever materialized at all.

109. The entire episode of trying to meet the requirement for multilateral military action was thus characterized by frustration. The failure perhaps demonstrates the distance between national policy desiderata unilaterally arrived at, in the abstract and before the event, and politico-military realities encountered in the concrete when those desiderata must be reconciled with differing national self-interests of others.

DEPLOYMENT AND SECURITY CONSIDERATIONS

110. June 3rd saw further progress in implementing the U.S. unilateral program of preparatory military measures. Forces ordered to be deployed were either on station, proceeding to, or in the process of outloading in preparation for movement into advanced positions. CINCLANT activated the Naval Task Fleet provided for in [] in order to facilitate execution of the plan if required, creating thus a Navy component command as a counterpart to the Army and Air Force task force commands which would operate under CJTF 122. The staff of CJTF 122 was augmented by the arrival at Guantanamo of personnel nominated by the Services and Department of State, joining the naval element of the staff already there, and the CJTF flagship NORTHAMPTON got under way, arriving in position south of Ciudad Trujillo the next day.^{2/} Meanwhile CINCARIB, reacting to reports of the deteriorating situation in the Dominican Republic, had placed Canal Zone Forces on DEFCON 4,

^{1/} (S) Msg, ALUSNA Caracas to CNO, 062230Z Jun 61.
^{2/} (TS) J-3 Dominican Republic Sit Rep 3-61, 3 Jun 61 and 4-61, 4 Jun 61; (TS) Talking Paper for State-JCS Meeting 9 Jun, prepared by Battle Staff 8 Jun 61.

and so advised JCS.^{1/} It was obvious that Dominican forces would be aware of all this U.S. military activity.

111. [

112. Both incidents were without consequence or significance, other than graphically demonstrating that the Dominican armed forces were not disaffected but should be counted on to contest U.S. military intervention. There were no other direct confrontations between elements of Dominican and U.S. armed forces during the remainder of the crisis.

113. Incidental but pressing technical problems of planning coordination between component forces also arose, requiring Battle Staff attention. That afternoon, in a JCS conference, the two

- 1/ (S) Msg, CINCARIB to JCS, CC 68267E, 031818Z Jun 61.
- 2/ (C) Msgs, CTU 81.7.2 to CTG 81.7 et al., 030620Z and 031034Z Jun 61; (TS) J-3 Dominican Republic Sit Rep 3-61 3 Jun 61.
- 3/ (C) Msg, COMCARIBSEAFRON to CINCLANTFLT, 031829Z Jun 61; (TS) J-3 Dominican Republic Sit Rep 4-61, 4 Jun 61.

Deputy Directors of J-3 and representatives of the Battle Staff met with the Chairman, JCS, and Director and Vice Director, Joint Staff, to review overall planning for the Dominican Republic, especially airborne operations planning. This latter, involving inter-Service functions, was the most complex. To insure coordination, the Chairman accordingly directed that one Army airborne officer and one Air Force TAC officer be sent to Norfolk and Fort Bragg. Two Battle Staff members were designated, departing immediately and returning the next day.^{1/} Military posture was reaching a state of readiness without major hitch.

114. By now the scale of the U.S. military commitment that had been set in motion began to pose a problem of its own. CINCLANT, noting that the magnitude of operational activity in connection with the Dominican situation -- [] -- could not be concealed from the public, recommended to JCS that the U.S. Government announce the purpose of these moves in order to preclude unfavorable interpretations of U.S. objectives.^{2/} Originally, the CINCLANT Public Information Officer had been instructed to explain the ship movements to the press as "routine operations." Then, at the request of OSD Public Affairs, the JCS had directed that there be no publicity and that any queries should be answered with "no comment."^{3/} But press attention already was giving widespread publicity to the ship movements, in considerable detail, and drawing knowledgeable inferences.^{4/} Accordingly, CINCLANT's suggestion was acted upon and arrangements were made to release general statements, attributable to unspecified "high Government sources," explaining U.S. intentions as merely precautionary moves.^{5/} Despite the magnitude

^{1/} (TS) JCS Dominican Republic Battle Staff Log.

^{2/} (S) Msg, CINCLANT to JCS (Personal for Chairman), 031730Z Jun 61.

^{3/} (TS) JCS Dominican Republic Battle Staff Log; (S) Msgs, JCS 996895 and JCS 996973 to CINCLANT et al., 021501Z and 022249 2 Jun 61.

^{4/} (U) New York Times, 3 Jun 61, pp. 1, 2.

^{5/} (U) New York Times, 4 Jun 61, pp. 1, 3.

~~TOP SECRET~~

of the U.S. military undertaking, there was comparatively little emphasis given to it by news media throughout the crisis.

115. Dominating all other developments during 3 June, however, was intelligence. The need to discover the nature and meaning of the situation existing within the Dominican Republic, with its elusive tangle of manifest and latent factors, was now recognized as the paramount consideration on which a U.S. national policy decision would depend.

~~TOP SECRET~~

~~TOP SECRET~~

POLITICAL INTELLIGENCE

116. Throughout the day of 3 June, efforts on many levels and from many sources were made to distill a general intelligence conclusion of policy relevance to the U.S. regarding the Dominican situation. Most of them in attempting to perceive, isolate, and define significant larger patterns, were intelligence analyses, interpretations, or estimates, and were largely based on collations of information acquired previously, instead of new reports of specific intelligence indications. Many of them, moreover, were impressionistic, rather than inferential, and some were speculative. Other than recapitulation and evaluation, little added grist was fed into the intelligence mill.

PERCEPTION OF THE POLITICAL SITUATION

117. [REDACTED] Ramfis was the leading power element in the Dominican Government and that the regime was increasing terrorist activities against the dissident opposition. It also contained the negative information that there was still no evidence of any political action having been taken by the dissidents to follow up the assassination in order to complete the overthrow of the Trujillo regime.^{1/}

b1
s

118. [REDACTED] a Navy Intelligence evaluation submitted to CNO, which stated there was a growing suspicion that the assassination of Trujillo may have been engineered by the present regime, possibly with the knowledge of Ramfis. "Signs tending to support this interpretation were enumerated. A conclusion was accordingly drawn that, if the foregoing evaluation were correct, the present Dominican Government could not be overthrown by any dissident elements without massive outside aid."^{2/}

[REDACTED]
^{2/} (S) Msg, DIO, 10 ND to CNO, 031533Z Jun 61.

~~TOP SECRET~~

~~TOP SECRET~~

Another Navy analysis a few hours later concluded that a struggle for power among Dominican military elements was likely if either Ramfis or Abbes, or the two of them together with Ramfis as front man, would head up a new government.^{1/}

119. A relatively conservative Battle Staff interpretation contained in the Sit Rep covering 3 June described a situation wherein the present regime was firmly entrenched and in the process of consolidating its position further by eliminating any vestige of opposition. Dissidents still remained in hiding while Dominican internal security forces (SIM) combed the countryside trying to hunt down everyone connected with the assassinator in any way, including relatives of members of the activist group and others associated, even indirectly or incidentally, with them. Indications were that the Catholic Church, as well as prominent U.S. nationals, would be charged with complicity in the assassination plot.^{2/}

CONCEPTION OF A REIGN OF TERROR

120.

b1
3

^{1/} (S) Msg, CNO to COMSECONDFLT, et al., 031855Z Jun 61.
^{2/} (TS) J-3 Dominican Republic Sit Rep 3-61, 3 Jun 61.

~~TOP SECRET~~

[

b1
S

]

122. An hour later the Consul General, responding directly to a specific query earlier by the State Department, rendered an evaluation of the situation that seemed to sound the death knell for whatever lingering hopes there were that the dissident cause, and the U.S. course of action predicated on it in accordance with the Political Contingency Plan, might still have some prospect of success. The Consul General stated that neither Estrella nor any of the dissidents, or the military associated with them, would survive if the Government's suppression of the opposition continued. In his opinion, the situation would worsen, because the Trujillo family had no choice but to exterminate the opposition or lose all.^{3/}

b1
S

- 1/ (TS) Msg, Ciudad Trujillo to Sec State, 1318, 040220Z Jun 61.
- 2/ (S) Msg, Ciudad Trujillo to Sec State, 1315, 040300Z Jun 61.
- 3/

123. In the midst of this progressively developing view of a state of terror and a hostile regime in the Dominican Republic, Ramfis held a press conference to give an official version of the situation. According to the Consul General, who had been immediately briefed by newsmen attending the conference, Ramfis disclaimed being anti-U.S. and asserted that the Dominican Government and its policies were pro-Western. He further stated that Balaguer had his full support and that of the armed forces, and any Castro invasion attempt would be repelled. Ramfis maintained that internal conditions were calm; there were, he insisted, only 50 or 60 prisoners being held in the entire country, who could be seen by the press after they were formally charged, while amnesty had been decreed for all others. Giving assurances that free democratic elections would be held in due course, he indicated that the proposed sending of an OAS Observer Commission into the Dominican Republic to investigate political conditions would be welcome.^{1/} The Consul General, in assessing the press conference, discounted most of the remarks made by Ramfis.^{2/}

124. At 2300 hours, three other messages from the Consul General further sharpened the image of terrorist conditions depicted in his earlier appraisals of the Dominican situation. In one message, he informed the Secretary of State that a reliable representative of a pro-U.S. dissident group reported a blood bath under way. The representative estimated the Ramfis-Abbes clique could survive for only a few weeks but in the interim would do great damage in an effort to purge all opposition. Forceful U.S. and OAS action was therefore needed immediately if the full effects of the terrorism were to be averted. Many Dominicans,

^{1/} (OUO) Msg, Ciudad Trujillo to Sec State for OSD, et al., 1316 040300Z Jun 61; New York Times, 4 Jun 61, pp. 1, 3.
^{2/} (C) Msg, Ciudad Trujillo to Sec State, 1317, 040400Z Jun 61.

~~TOP SECRET~~

the dissidents' representative maintained, were ready to take over if outside support were available.^{1/} Another message from the Consul General reported that Consuls and Ambassadors of other countries in Ciudad Trujillo observed the same conditions of terror existing in the Dominican Republic as he did.^{2/} This was later officially denied by their home governments (see par. 146 below). In the third message, the Consul General submitted a list of people reportedly arrested, pointing out that many of these were the type the U.S. would wish to see in positions of leadership in a free Dominican Republic.^{3/}

125. Shortly thereafter the Consul General, now thoroughly convinced of the ruling clique's capacity for malevolence, also commented on two incidents of mob violence directed at Leftist political elements that had occurred that day. In his view the incidents were presumably regime-inspired, in order to give the impression of the Government being anti-Communist and the people solidly behind it.^{4/} If this interpretation were correct, the regime indeed enjoyed a high degree of control over the situation.

END OF THE DISSIDENTS' ROLE

126. It was at this time that the U.S. first learned the main outlines of what had happened on the night of 30 May when the crisis was originally kicked off by the assassination of Trujillo. Although portions of the study, in unconfirmed versions, had been learned the day before and were duly reported then,^{5/} only now were enough missing parts filled in so that a reasonably coherent and credible reconstruction was possible. The Consul General forwarded information purportedly relating the circumstances

1/ (S) Msg, Ciudad Trujillo to Sec State, 1319, 040400Z Jun 61.

2/ (C) Msg, Ciudad Trujillo to Sec State, et al., 1321, 040400Z Jun 61.

3/ (C) Msg, Ciudad Trujillo to Sec State, 1324, 040400Z Jun 61.

4/ (OUO) Msg, Ciudad Trujillo to Sec State, 1307, 040613Z Jun 61.

5/ (S) Msg, Ciudad Trujillo to Sec State, 1303, 030400Z Jun 61.

~~TOP SECRET~~

• surrounding the assassination plot, and explaining the lack of follow-through with a coup attempt. He reported that, according to informed sources, the failure of the plan to overthrow the Trujillo regime when the Benefactor was assassinated was due to failure to reach General Roman, Secretary of State for Armed Forces. Roman was to have had a crucial role in the plot. The plan called for Trujillo's body to be placed in the trunk of a car and delivered to Roman, who would then be "captured" and forced to summon key members of the Trujillo family to come for the body, at which time they would all be killed. At the critical moment, however, Roman could not be found, and the car with Trujillo's body in the trunk was abandoned at the home of General Diaz where it was later discovered by Dominican security personnel.^{1/} This account, as subsequently corroborated and amplified, proved to be substantially accurate. It cast considerable light on the present situation.

127.

1/ (C) Msg, Ciudad Trujillo to Sec State, JCS, et al., 1325, 040500Z Jun 61.

2/

b1
5

128. Simultaneously, other indications pointed to the Dominican regime itself having written off the dissidents a long time ago, to the extent of now affording itself the luxury of attention to its "image." Near noon, the Consul General reported on a press conference held by President Balaguer. The Dominican President gave assurances that his Government intended to follow a democratic line. He promised free elections in May 1962, as well as freedom of the press and freedom for political parties to operate, including tolerance of opposition. He denied the existence of any Castro-Trujillo understandings, and claimed it was his Government's desire to resume relations with OAS countries. In appraising these statements, the Consul General expressed reservations about Balaguer's sincerity and determination.^{2/}

129. A final intelligence fillip, uncommonly current and specific, was added late that night when the Consul General reported that SIM, by spreading rumors, was exploiting the presence of U.S. Naval forces near Dominican waters as evidence of U.S. support for Trujillo's heirs.^{3/} The Voice of America undertook to counter the rumor campaign.

THE NATIONAL INTELLIGENCE IMPRESSION

130. It was as a result of this somewhat monothematic intelligence reiteration, intensifying what had been emerging over the previous

b1
5

- 1/ [REDACTED]
- 2/ (OOO) Msg, Ciudad Trujillo to Sec State, 1326, 041628Z, Jun 61; New York Times, 5 Jun 61, p. 3.
- 3/ (S) Msg, Ciudad Trujillo to Sec State, 1334, 050300Z Jun 61.

~~TOP SECRET~~

several days, that a general strategic intelligence impression of the Dominican situation began to crystallize along the following lines:

- a. The Dominican internal situation was stable.
- b. There was no apparent outside Castro/Communist interference so far.
- c. A successor Government was firmly in control, with the constitutional President (Balaguer) the titular head of state but Ramfis and/or Abbes actually wielding power.
- d. The dissidents were impotent and facing annihilation.
- e. A ruthless campaign of unchecked repression and terrorism was being waged by and on behalf of the Trujilloist-controlled center of power against all opposition in a determined effort to eliminate any potential challenge to its position.

131. Central and salient, because of the emphasis given to it, was this last point regarding the existence of a reign of terror. Such an intelligence impression had been largely generated by interpretations emanating from [redacted] Ciudad Trujillo. [redacted]

b1
5

132. Significantly, the character of the intelligence impression, as well as most of the intelligence reports on which it had been based, was almost exclusively political. Implied was that the relevant issues and forces involved in the crisis were the internal political aspects of the Dominican situation. Not only were these denying the crisis taking on a military dimension, but they were likely to be determining upon the outcome.

[]

133. []

134. The proposal was formally taken under consideration by JCS the next day, going "green" as JCS 2338/1, dated 5 June 1961. But no decision was ever made. On 14 June, after the substance of the recommendation had been overtaken by events, the JCS paper containing the proposal was withdrawn from further consideration by JCS at the request of the originator.^{2/}

135. The proposal, however, apparently did serve to stimulate interest in the idea of a show of force, for active consideration began to be given the same day to the desirability of sending

1/ (S) Memo, Vice CNO to JCS "Means to Influence the Government of the Dominican Republic (U)," 4 Jun 61, encl to JCS 2338/1, 5 Jun 61.

2/ (S) N/H JCS 2338/1, 14 Jun 61.

one or two U.S. vessels closer to the Dominican coast.^{1/} This culminated the following day in a State Department decision to do so, but in a way somewhat less dramatic than the Vice CNO proposal. After much interdepartmental conferring, involving approval by the Acting Secretary of State and the Secretary of Defense, the Vice Director of the Joint Staff released a JCS message directing CINCLANT to position one destroyer off Ciudad Trujillo just over the horizon.^{2/}

^{1/} (TS) JCS Dominican Republic Battle Staff Log.
^{2/} (TS) Ibid.; (S) Msg, 997004 to CINCLANT, 051609Z Jun 61; (OUO) Exegetic notation on Aide-Memoire [sic], Ch Combat Ops Div, J-3, "Gist of Telephone Call from Mr. Achilles, State Department," 5 Jun 61.

BEGINNINGS OF A STRATEGY READJUSTMENTTHE CONSUL GENERAL'S PROPOSAL

136. But the important event of 4 June occurred inside the Dominican Republic. . It was another of the critical incidents of the crisis.

137. At noon, at Balaguer's request, the U.S. Consul General called on the Dominican President. Balaguer wanted to dispel erroneous notions of a reign of terror existing, maintaining that the real situation was quiet and stable. Insisting that his Government, already pro-Western and anti-Communist, was trying to effect a transition toward democracy, he declared that his own political purpose was only to see that free elections, scheduled for 16 May 1962, would be carried out, when he would step down from the Presidency. In response to the Consul General's expressions of apprehension regarding the safety of U.S. citizens residing in the Dominican Republic, Balaguer assured him that there was no cause for concern.

138. The Consul General, now convinced of Balaguer's sincerity and good intentions, recommended that, as evidence of his earnestness and determination, he first constrain SIM by getting rid of Abbes and General Espaillet, which Balaguer quickly agreed to do, and that he seek support of democratic opposition elements for his program of reform. Then, after informing him that the U.S. would honor a request for military assistance in the event of Castro or Communist attack from abroad, the Consul General stated, "...the U.S. was prepared to help him militarily any time at his request if he encountered obstacles from recalcitrant sectors of the Dominican military who might be bent on preventing him from his progress toward democracy." At this last, Balaguer appeared relieved and grateful. The Consul General, in reporting the interview to the Secretary of State, commented

~~TOP SECRET~~

that the reassurance that the U.S. would protect him from Trujilloist military power could be expected to give Balaguer the needed confidence to implement his policies.^{1/}

139. The records available do not reveal whether the Consul General had been explicitly authorized to make such commitments on behalf of the U.S. as he had just done. Inferring from subsequent communications between him and the Acting Secretary of State, there is a suggestion that he may conceivably have acted on his own responsibility. Whatever the circumstances, this action by the Consul General constituted the most important U.S. decision in the crisis. The State Department did not disavow the Consul General's action then or later. As borne out by events that followed, the U.S. had in effect opted for a complete reversal of its former policy objective; namely, to sustain rather than remove the incumbent Dominican Government.

140. The evening of the same day, the Consul General, on the basis of his conversation with Balaguer, advanced a proposal to the Acting Secretary of State along the lines he had already taken. Somewhat after the fact, he recommended that he be authorized to inform President Balaguer that Ramfis and other members of the Trujillo family must be purged from public positions, preferably ousted from the country, and that, if Balaguer wished, the U.S. would provide within hours, at his request, the necessary military help to accomplish this purpose. A new Cabinet would then have to be formed, consisting of a coalition of prominent opposition leaders of democratic, anti-Communist persuasion, after which U.S. forces would be withdrawn as soon as Balaguer decided that stability was assured.^{2/}

^{1/} (S) Msg, Ciudad Trujillo to Sec State, 1331, 042400Z Jun 61.
^{2/} (S) Msg, Ciudad Trujillo to Sec State, 1334, 050200Z Jun 61.

~~TOP SECRET~~

141. Although there apparently was no formal, institutionalized decision process involved, the proposal was ostensibly adopted as the U.S. position on the basic political issues in the crisis, for the next day the course of action that had already been initiated by the Consul General in his talk with Balaguer was followed up by the State Department. An attempt was made to marshal support among other countries for the new policy posture and objectives.

INFLUENCE OF ALLIES' VIEWS

142. On 5 June the U.S. Ambassador in Caracas was instructed to apprise the President of Venezuela of the Consul General's overtures to Balaguer of the previous day, informing him of the U.S. position and requesting his views. He was to tell the Venezuelan President that the U.S. now believed the best solution possible for the Dominican situation, under the circumstances, would be an interim government headed by Balaguer, but composed of prominent democratic anti-Communists and free of totalitarian elements such as Ramfis, Abbes, and Espaillat, which would pledge itself to establish the necessary preconditions for free elections in 1962. To achieve this, Balaguer might urgently require outside military assistance. The U.S. Ambassador was therefore directed to find out from the Venezuelan President, and through him in turn from the President of Colombia, whether the two countries would participate with the U.S. in responding to such a request for military assistance from Balaguer.^{1/}

143. The reply from the Ambassador in Caracas was that the President of Venezuela urged in strongest terms that the U.S. abandon the idea of landing forces in the Dominican Republic, on grounds that this kind of unilateral action would be "counter

1/ (S) Msg, Sec State to Caracas, 1175, 5 Jun 61.

productive." ^{1/} About the same time, the U.S. Charge in Bogota advised that the President of Colombia would probably not be receptive to any proposal for military intervention to support the Balaguer Government in the absence of external invasion or subversion. ^{2/} As a counterproposal, the President of Venezuela the next day offered a detailed program of his own for dealing with the crisis.

144. The Venezuelan President, in a meeting with the U.S. Ambassador, the U.S. Ambassador to the U.N., and others, on 6 June advocated that:

- a. The U.S. take no military measures alone.
- b. Any military intervention be only pursuant to authorization of the OAS under the Rio Treaty.
- c. The U.S. wait for the OAS Observer Group report on conditions in the Dominican Republic.
- d. In the interim, a show of forces of U.S.-Venezuelan forces be made.
- e. Balaguer be persuaded to get rid of Ramfis, Abbes and company.
- f. Balaguer be prevailed upon to institute democratic reforms and arrange for free elections.
- g. Balaguer be encouraged to form a temporary military-civilian junta to govern until the elections. ^{3/}

145. As matters ultimately worked out, this proved to coincide closely with the program eventually followed by the U.S.

146. It was during 5 June, and for the succeeding few days, that the response came from the various countries that had been approached regarding their respective views of the Dominican

^{1/} (S) Msg, Caracas to Sec State, 1213, 052400Z Jun 61.
^{2/} (S) Msg, Bogota to Sec State, 579, 052300Z, Jun 61.
^{3/} (S) Msg, Caracas to Sec State, 1222, 062100Z Jun 61.

~~TOP SECRET~~

internal situation. The U.S. Ambassadors concerned reported that none of the governments agreed with the U.S. appraisal of terrorism. France, the United Kingdom, Spain, West Germany, and Nationalist China all stated unequivocally that they were not aware of any reign of terror existing in the Dominican Republic. Some of them had been implicitly critical of the U.S. on this point, or even of U.S. policy toward the Dominican crisis generally.^{1/} The Government of Paraguay, for example, not only categorically disapproved of any intervention in the Dominican Republic, but was "flatly against" even sending OAS observers into the country.^{2/}

RECALL OF THE CONSUL GENERAL

147. At 0915 hours on the morning of 5 June, the Director of the State Department Operations Center telephoned the Battle Staff to relay the information that the U.S. Consul General in Ciudad Trujillo was being recalled. On instructions of the Attorney General [sic], the Consul General had been directed to return to Washington on the next plane in order to consult with President Kennedy upon his return from Europe the following day, 6 June.^{3/} The Consul General did not go back to his post in Ciudad Trujillo after the consultation with the President, but was relieved, being replaced by a Latin-American specialist in the State Department.

LULL IN THE DOMINICAN SITUATION

148. Meanwhile, the internal situation within the Dominican Republic seemed to be showing signs of regaining a measure of

^{1/} (C) Msgs, Paris to Sec State, 5335, 5 Jun 61; London to Sec State, 4948, 5 Jun 61; Madrid to Sec State, 1295 5 Jun 61; Bonn to Sec State, 2037, 6 Jun 61; Taipei to Sec State, 774, 8 Jun 61.

^{2/} (C) Asuncion to Sec State, 228, 062300Z Jun 61.

^{3/} (OUO) Aide-Memoire, Ch Combat Ops Div J-3, "Gist of Telephone Call from Mr. Achilles, State Department," 5 Jun 61.

~~TOP SECRET~~

stability. Early in the morning (5 June) it was learned that General Diaz, one of the key figures in the assassination plot, had been killed by SIM late the night before, along with two other members of the group. Not long thereafter it was also learned that General Estrella, one of the dissident leaders in whom so much hope had been placed, was under arrest.^{1/} And, as if to underline the end of the last traces of life in what remained of the original dissident movement, a final desperate appeal was made for U.S. intervention. A trusted spokesman for the dissidents relayed a plea that if anything were to be done it had to be done now while there was still time, for there might not again be another opportunity.^{2/} The negative rationale, as well as the note of hopelessness, implied an admission by the dissidents that even they no longer considered themselves a factor in the course of events.

149.

b1
S

150. Before the day was over the Balaguer Government agreed to the entry of the investigating subcommittee appointed by the Special Committee of the OAS Council to observe conditions in the Dominican Republic. The Observer Team membership would consist of representatives of the U.S., Mexico, Uruguay, and Panama.^{5/}

J

b1
S

- 1/ (C) Msg, COMCARIBSEAFRON to CNO, 050623Z Jun 61; (U) New York Times, 5 Jun 61, pp. 1,3; (TS) JCS Dominican Republic Battle Staff Log.
- 2/ (S) Msg, Ciudad Trujillo to Sec State, 1339, 051600Z Jun 61.
- 3/ (TS) J-3 Dominican Republic Sit Rep 5-61, 5 Jun 61.
- 4/
- 5/ (U) New York Times, 6 Jun 61, pp. 1,3; (TS) J-3 Dominican Republic Sit Rep 6-61, 6 Jun 61.

POLITICO-MILITARY OPERATIONAL QUESTIONS

POLITICAL GUIDELINE REQUIREMENTS

151. As the complexity and importance of political factors in the crisis now became increasingly self-evident, the U.S. commander responsible for contingency military operations required appropriate terms of reference to guide him wherever political considerations impinged upon military actions. Neither political nor military planning had treated this problem. Accordingly, the Political Adviser to COMSECONDFLT, presumably at the behest of COMSECONDFLT, recommended to the Acting Secretary of State that political guidance be prepared governing the Commander's relationship with the U.S. Consul General in Ciudad Trujillo, the Dominican Government, and the Dominican populace, should the contingency plan for the Dominican Republic be implemented. If the present constitutional (Balaguer) government were to be supported, such guiding instructions on the use of U.S. forces would especially be needed. A specific request was also made for intelligence estimates regarding public attitudes toward U.S. forces that could be expected in the event of a military move into the Dominican Republic.^{1/}

152. Thereby was opened a Pandora's box of immediate operational problems, hitherto totally ignored, that could only be resolved by policy decisions on the highest national level.

PSYCHOLOGICAL WARFARE REQUIREMENTS

153. One of the technical operational problems of such national policy implications pertained to public information and propaganda. Not only was delineation of responsibility and procedures

^{1/} (S) Msgs, COMSECONDFLT POLAD to Sec State, No. 3, 051449Z and No. 4, 051451Z Jun 61.

lacking for dealing with conventional journalistic interest in the prospective operation,^{1/} but there was also no official subject basis for defining the objectives and controlling the substance of psychological warfare activity. The Army Civil Affairs Team, which had responsibility for conducting psychological warfare operations under [] had undergone refresher training oriented to the Dominican Republic the preceding April.^{2/} But events since then had radically altered the political environment in which psychological warfare would have to function and the circumstances to which it would be addressed. Moreover, the now predominantly political dimensions of the crisis situation demanded the closest coordination between military propaganda and the national policy it would articulate.

154. The Civil Affairs Team accordingly had requested COMSECONDFLT to provide policy guidance on the thematic content of propaganda output in connection with the Dominican contingency plan. COMSECONDFLT referred the matter to his Political Adviser, who in turn referred it indirectly, through the Department of the Army, to the Department of Defense and Department of State. The Political Adviser, in a message to the Department of the Army on 7 June, reported the background of the problem and advised that what was required was guidance on the following:

- a. Justification for U.S. military intervention.
- b. U.S. future intentions regarding presence of forces, conditions of withdrawal, etc.
- c. U.S. political policy toward Dominican internal affairs during the period of intervention.
- d. U.S. policy on economic matters, labor, religion, etc.

^{1/} (S) Msg, CINCLANT to JCS, 052354Z Jun 61.
^{2/} (TS) Memo, JCS to Gen Clifton, "Dominican Republic," approximate date 5 May 61.

155. He recommended that, inasmuch as these questions involved other departments of government besides the military, the Department of Defense consult with the State Department, which had a primary interest, in preparing the requested guidance. He then offered suggested points for inclusion in any terms of reference that might be provided for a propaganda presentation of the U.S. position.^{1/}

156. Meanwhile, on 6 June, CINCLANT had instructed COMSECONDFLT/CJTF 122 to include in his plans provision for airdrop of warning leaflets to the Dominican population prior to military operations, with the leaflet content to be developed in accordance with applicable portions of Annex A of [

] COMSECONDFLT took the occasion to apprise CINCLANT of the larger problem regarding propaganda raised by the Army Civil Affairs Team, which was not adequately covered by the guidance contained in Annex A of the contingency plan. CINCLANT accordingly repeated, in a message to JCS on 8 June, a request that national policy guidance be provided for psychological warfare operations, identifying the same four subject areas as COMSECONDFLT's Political Adviser the day before. He also indicated a lack of trained and experienced psychological warfare personnel at his disposal for the required planning involved.^{2/}

157. The requested guidance was never furnished. For one thing, the magnitude of the task of formulating a capsulated statement of U.S. national policy toward the Dominican Republic that would be at once comprehensive and definitive, even if feasible, required considerable time to achieve all the necessary coordination before a concensus could be reached on the U.S.

^{1/} (S) Msg, COMSECONDFLT POLAD (NO. 13) to D/A, 072109Z Jun 61.
^{2/} (S) Msg, CINCLANT to JCS, 081843Z Jun 61.

Government's official position on each detail. Secondly, to the extent that such a statement would apply to a future situation, the character of which was unknown, it would constitute a policy commitment that might later prove inappropriate. By this time, however, the need for national policy guidance for possible military propaganda operations was rapidly being overtaken by events and the likelihood of intervention receding. Late in the afternoon of 8 June, CINCLANT postponed deployment of the Army Civil Affairs Team from CONUS, requesting it to remain at Fort Gordon in ready status.^{1/} The next day (9 June) the new Consul General in Ciudad Trujillo requested a Public Affairs Officer for the Consulate to assume responsibility for informational requirements in support of U.S. objectives with both foreign and domestic news media.^{2/}

^{1/} (S) Msg, CINCLANT to CG CONARC, 081252Z, Jun 61.

^{2/} (C) Msg, Ciudad Trujillo to Sec State, 1365, 091700Z Jun 61.

DEGREE OF FORCE ISSUES

158. Another policy problem that arose on 5 June was more directly military. It too had not been touched upon in contingency planning. CINCLANT, in order to prepare the JCS-directed revision of [] for employment of augmented forces, requested guidance of JCS specifying the degree of force permitted to be used tactically in the initial phase of contemplated operations.^{1/} At the same time CINCLANT informed CJTF 122 that preassault combat preparations might be required, but that the magnitude permitted would be specified by higher authority when execution of the assault was ordered. Nevertheless, CINCLANT directed him to amend his plans so as to provide for such preparatory measures with little advance notice, offering general guidance in outline on the possible range, in kind, degree, timing, and duration, of such operations, as well as an indication of limitations on them.^{2/}

159. The matter was taken under consideration by JCS, and the next morning an interim response, advising on the status of the question, was conveyed to CINCLANT by the Battle Staff.^{3/} The formal reply to CINCLANT's request was sent the same afternoon, 6 June, at 1400 hours. JCS stated that the degree of force that might be applied by U.S. forces prior to and in preparation for actual assault operations could not be determined in advance, inasmuch as this would depend upon political objectives which could only be set in the light of the political situation at the time intervention was decided upon. CINCLANT therefore was instructed to draw up plans for the following three alternatives:

- a. Issuance of an ultimatum to Dominican Republic armed forces prior to U.S. intervention, to the effect that any resistance would be met with overwhelming force.

^{1/} (S) Msg, CINCLANT to JCS, 052212Z Jun 61.
^{2/} (S) Msg, CINCLANT to CJTF-122, 052244Z Jun 61.
^{3/} (TS) JCS Dominican Republic Battle Staff Log.

b. No prior warning. but limited pre-H-hour military measures restricted to air strikes on selected airfields and certain military installations, plus preparations to attack Dominican aircraft taking off from airfields.

c. Pre-H-hour preparatory attacks on airfields and military installations generally.

Further comments and recommendations in the matter from CINCLANT were invited.^{1/}

160. Three days later (9 June), CINCLANT did comment, taking exception to the first of the three alternatives contemplated. He recommended to JCS that the issuance of a warning and ultimatum prior to military action be eliminated from consideration, on the grounds that its effect would be to increase resistance, thus requiring greater force to be applied and resulting in more severe damage and greater casualties.^{2/} Again, by this date (9 June) the whole policy issue of force was becoming academic, for it was already largely overtaken by events and the likelihood of any tactical military operations becoming remote. Consequently, there was no further need to resolve the problem in specific detail.

RULES OF ENGAGEMENT

161. A third policy consideration also arose on 5 June, one that similarly pertained to military operations but had important political implications. This was the touchy question of how to deal with potential Cuban military interference with U.S. forces participating in operations related to the Dominican situation, a latent reflection of the original strategic concern over Cuban military exploitation of the Dominican crisis. Rules of engagement covering this contingency were drawn up by CINCLANT, based on approved JCS policy cited.

^{1/} (TS) Msg, JCS 99701 to CINCLANT, 062125Z, Jun 61.
^{2/} (TS) Msg, CINCLANT to JCS. 092234Z Jun 61.

162.

7

en

163. The next day (6 June) CINCLANT cancelled his message above, regarding rules of engagement, on the grounds of its having been addressed in error.^{2/} Yet two days later, on 8 June, CINCLANT apprised JCS of guidance he had issued for LANTCOM forces, repeating the same rules of engagement laid down in his first message to COMTAC and CG CONARC on 5 June, and advised JCS that he proposed to provide these to CJTF 122, COMTAC and CG CONARC.^{3/} A notation appearing on the margin of a copy of the message in the Battle Staff files indicates that this last message to JCS of 8 June had also been cancelled by CINCLANT's cancellation message of 6 June. The anachronism, between messages themselves as well as between notation and messages, remains unexplained. No record of JCS response to CINCLANT's message of 8 June has been found, but the issue was included by the Battle Staff in their formal briefing paper for the JCS as one of the questions to be taken up at the

- 1/ (TS) Msg, CINCLANT to COMTAC and CG CONARC (Info JCS), 052252Z Jun 61.
- 2/ (TS) Msg, CINCLANT to COMTAC and CG CONARC (Info JCS), 061549Z Jun 61.
- 3/ (TS) Msg, CINCLANT to JCS, 082032Z Jun 61.

~~TOP SECRET~~

State-JCS meeting of 9 June. By this time, here too the policy issue of tactical response to Cuban military interference was no longer of immediate practical relevance. Besides, the rules of engagement that had been given were nothing more than a reiteration of existing JCS policy guidance covering such contingencies. There were no incidents with elements of the Cuban armed forces at any time during the crisis.

~~TOP SECRET~~

ACHIEVING MILITARY READINESS

FORCE READINESS STATUS

164. On 5 June, the military readiness posture of U.S. forces committed to the contingency operation was quickly reaching the level required by the respective DEFCON's and deployment positioning specified.

165. [

a.

b.

c.

166.

a.

b.

c.

I/ (S) Msg, COMSECONDFLT to CINCLANTFLT, 050411Z Jun 61. J

a.

167.

a.

b.

c.

168.

a.

b.

- 1/ (S) Msg, CG XVIII ABN Corps to CINCLANT et al., 1051, 060013Z Jun 61.
- 2/ (TS) Talking Paper for State-JCS Meeting - 9 Jun, prepared by Battle Staff, 8 Jun 61.

c.

d.

e.

169. CINCLANT, in a consolidated force-readiness status report submitted to JCS late in the afternoon of 5 June, gave the estimated reaction time to execute the Dominican Republic contingency plan provided for in [] as follows:

a. Naval forces were in position and ready to commence naval operations any time on order.

b. The initial Marine amphibious assault would commence within 4 hours after the execution order.

c.

I/ (S) Msg, CINCLANT to JCS, 052324Z Jun 61.

~~TOP SECRET~~

These estimates were for daylight, and were further contingent upon weather and wind conditions and the amount of preassault preparatory attack needed.^{1/}

FORCE READINESS ESPRIT

170. Thus by 5 June a major assault force had been marshalled and was poised ready to undertake large-scale military operations. In the process of reaching this state, the mass and velocity of the build-up had achieved a momentum which now was abruptly stopped short at the critical point and not permitted to run its logical course. The resulting impatience on the part of participants involved, evidence of which has already been seen earlier, began now to show signs of frustration over the restraints imposed and the attendant waiting and inactivity.

171. A submarine had joined the Second Fleet forces on 5 June. The Political Adviser to COMSECONDFLT, at the latter's request, advised the Acting Secretary of State of the recent addition of the submarine, giving COMSECONDFLT the capability of covert contact with shore should it be desirable to place individuals on or take them off the beach.^{2/} In another message a few minutes later the Political Adviser suggested to the Acting Secretary of State that it might be desirable for COMSECONDFLT to go ashore by helicopter and confer with Balaguer and the U.S. Consul General, among other things to strengthen Balaguer's will by reassuring him personally of the U.S. military support available.^{3/}

172. The same theme was pursued the following day, 6 June. The Political Adviser recommended to the Secretary of State that consideration be given to the desirability of covert submarine contact with the Dominican shore, or a covert or overt personal visit by

1/ (S) Msg, CINCLANT to JCS, 052122Z Jun 61.
2/ (S) Msg, COMSECONDFLT POLAD to Sec State, No. 6, 051633Z Jun 61.
3/ (S) Msg, COMSECONDFLT POLAD to Sec State, No. 7, 051635Z Jun 61.

~~TOP SECRET~~

COMSECONDFLT to President Balaguer. COMSECONDFLT could either land by helicopter or submarine, or arrive overtly by destroyer, the latter in the guise of shore liberty or ostensibly for emergency repairs. One purpose of such contact or visit might be to help Balaguer escape briefly from the Dominican Republic in order to return within a few hours accompanied by the U.S. Fleet. The Political Adviser assured the Secretary of State that the Second Fleet possessed the capability for the range of possible actions suggested.^{1/} During 6 June COMSECONDFLT did manage to find occasion to utilize the submarine. On CINCLANT's authorization, an undetected daylight surveillance patrol by submarine was conducted in the vicinity of Jaina Beach near Ciudad Trujillo, the main planned assault beach, to determine the extent of Dominican ship patrolling of the area.^{2/}

173. In these messages, as well as others from the COMSECONDFLT Political Adviser referred to earlier, COMSECONDFLT had effectively used the Political Adviser assigned to his staff by the State Department as a medium of communication through which to address himself directly to the Secretary of State. Thereby the tactical commander was able to bypass all of the military channels: CINCLANT, JCS, CNO, and the Secretary of Defense.

174. Authorization had been granted on 5 June for direct communication between the U.S. Ambassadors in Venezuela and Colombia and the Consul General in Ciudad Trujillo for the duration of the emergency, in order to save time, and the repeating of appropriate message by them to the Political Adviser CINCARIB and the Political Adviser COMSECONDFLT was also authorized.^{3/} Similarly,

- ^{1/} (S) Msg, COMSECONDFLT POLAD to Sec State (unnumbered) (no date-time group indicated), 6 Jun 61.
^{2/} (TS) J-3 Dominican Republic Sit Rep 7-61, 7 Jun 61.
^{3/} (S) Msg, Sec State to Caracas (1181), Bogota (774), Ciudad Trujillo (783), 051331Z Jun 61. (NOTE: examination of the technical details of these communication channels, such as circuits, equipment, and traffic patterns, is outside the scope of the present study, and has been deferred, to be treated later in a separate paper.)

the next day JCS authorized direct communication between CINCLANT and CINCSAC on operational matters pertaining to the Dominican Republic contingency plan.^{1/} But there was no explicit authorization for COMSECONDFLT to communicate with anyone other than through normal military channels.

175. COMSECONDFLT's overtures to the Secretary of State through his Political Adviser were, however, unsuccessful in initiating a colloquy on any of the subjects raised, either in these or subsequent POLAD messages. The only specific response to COMSECONDFLT's promptings, suggestions, and proposals was on 8 June in regard to the submarine, and it was addressed to the Consul General in Ciudad Trujillo, with instructions to repeat the message to COMSECONDFLT's Political Adviser. The Secretary of State informed the Consul General that use of the U.S. submarine with the Second Fleet for clandestine shore contacts, such as pick-up or landing of individuals, was not contemplated.^{2/}

176. Late at night on 5 June, COMSECONDFLT made one more attempt to gain for himself and his forces a more active role in the crisis. In a direct communication, he apprised the Consul General in Ciudad Trujillo of the size, composition, and capabilities of the forces available for operations to meet various contingency developments in the Dominican situation. Again, COMSECONDFLT indicated he was available to come ashore personally for discussions. A message advising that the foregoing had been communicated to the Consul General, and in the process repeating the contents, was sent by COMSECONDFLT to the Secretary of Defense, JCS, CINCLANT, CNO, Department of the Army, Chief of Staff,

^{1/} (S) Msg, JCS 997068 to CINCLANT and CINCSAC, 061452Z Jun 61.
^{2/} (S) Msg, Sec State to Ciudad Trujillo, 802, 8 Jun 61.

~~TOP SECRET~~

U.S. Air Force, and, through his Political Adviser as a separate message, to the Acting Secretary of State.^{1/} But the source and focus of influences determining U.S. action were beginning to shift away from the Dominican area to developments in Washington.

^{1/} (S) Msg, CONSECONDFLT to JCS, et al., 060333Z Jun 61;
(S) COMSECONDFLT POLAD to Sec State, No. 8, DTG unknown,
6 Jun 61.

~~TOP SECRET~~

POLICY REAPPRAISAL

177. Events of the next three days, although of no great decisive moment in themselves, proved to be important in shaping the final U.S. decision regarding intervention in the crisis. Interspersed were problems of considerable significance to command and control in conducting intervention operations.

THE CLARIFYING POLITICAL INTELLIGENCE INDICATORS

178. The intelligence picture of the Dominican internal situation, of 6 June, as reflected in the Battle Staff Sit Rep that day, noted little basic change from the quiet calm of the previous day. There was no indication of any opposition to the regime developing in the interior, and the capital was returning to normal. A tempering in the activities of the internal security forces of SIM was also apparent, with some of those arrested being released.^{1/}

179.

- 1/ (TS) J-3 Dominican Republic Battle Staff Sit Rep 6-61, 6 Jun 61.
- 2/ (S) Msg, Ciudad Trujillo to Sec State, 1346, 061700Z Jun 61
- 3/ (S) Msg, Ciudad Trujillo to Sec State, 1357, 081600Z Jun 61.

180. Perhaps the most significant intelligence development of the day was an announcement that the Army commission of the infamous Lt. Col. Abbes had been revoked, thereby deposing him from his position of power as de facto head of SIM. A few days later Abbes left the country to become Counselor of the Dominican Embassy in Tokyo. This act was interpreted as a deliberate gesture by the regime to disabuse itself of the police-state label and underscore its break with the alleged terrorism of the past.^{1/} The regime was at least going through the motions of sanitizing itself in compliance with U.S. policy desires.

181. At JCS, the apparent easing in the Dominican internal situation briefly raised the question of whether reconnaissance missions over Dominican territory were still being carried on. In a Battle Staff discussion of the question the Director and Vice Director, Joint Staff, were under the impression that no further missions, after the first two, were being flown, inasmuch as no authorization existed for any more such flights. The State Department had been strongly opposed on political grounds to military overflights in violation of Dominican airspace; therefore, only two photoreconnaissance missions had ever been authorized (originally, the State Department had reluctantly agreed to but one mission; then, because of poor weather conditions, had authorized a second). To reassure itself on this score, the Battle Staff checked with the CINCLANT Staff and confirmed that no more reconnaissance missions were being flown over Dominican territory.^{2/} However, surveillance around the periphery of the Dominican Republic, initiated on 31 May, was still being conducted, both by air and surface patrol. In fact, CINCLANT's situation report for 6 June

1/ Msg, Ciudad Trujillo to Sec State, 1349, 062400Z Jun 61; (TS) J-3 Dominican Republic Battle Staff Sit Rep 7-61, 7 Jun 61; New York Times, 7 Jun 61, p 3; (C) Msg, Ciudad Trujillo to Sec State et al., 1358, 081700Z Jun 61.
2/ (TS) JCS Dominican Republic Battle Staff Log.

(No. 10) expressly noted no unusual activity detected in such surveillance.^{1/} Surface and air patrols of the Windward Passage and air surveillance of the southern coast of Hispaniola continued for some time longer.^{2/}

POLICY REVIEW

182. During the morning of 6 June a State Department meeting, attended by the Consul General recalled from Ciudad Trujillo, was held to review the Dominican situation and U.S. actions pertaining thereto. Out of the review came a conclusion that the internal situation appeared to be subsiding for the moment. For this reason, and because Venezuela strongly objected to any armed intervention, it was decided that further U.S. action, political or military, was not indicated for the time being, but would be held in abeyance pending new developments within the Dominican Republic and the results of the OAS Observer Team. Shortly after the State Department meeting, the Chairman, JCS, sent a message to CINCLANT informing him of what had transpired at the meeting and advising him that no U.S. military operations, therefore, were imminent.^{3/}

183. Meanwhile the President had requested a meeting with the Chairman, JCS, to go over the military aspects of the Dominican situation. The Vice Director, Joint Staff, directed the Battle Staff to prepare a briefing book for the Chairman for this meeting. It was completed shortly before noon and the Chairman was briefed on its contents. However, the Presidential meeting was postponed until the next day.^{4/} Implied by the postponement was that urgency of decision as to what action the U.S. should take next was not considered crucial to the outcome of the crisis.

1/ (S) Msg, CINCLANT to JCS, 070002Z Jun 61.

2/ (S) Msg, CINCLANT to JCS, 120002Z and 122237Z Jun 61.

3/ (S) Msg, CJCS to CINCLANT (JCS No and DTG unknown - approx. 1500Z), 6 Jun 61.

4/ (TS) JCS Dominican Republic Battle Staff Log.

184. Consistent with the policy posture of avoiding precipitous action, the new U.S. Consul General in Ciudad Trujillo, who had assumed charge upon arrival late in the afternoon of 6 June, was accordingly instructed to hold the diplomatic line already established. He was directed to make no commitments should Balaguer pursue further the U.S. proposals made on 4 June. Instead, he was to urge Balaguer, if the opportunity presented itself, to cooperate with the OAS Observer Group so as to gain its support. ^{1/}

185. In view of a now impending reappraisal of U.S. strategy, the State Department undertook a review of the Political Contingency Plan for the Dominican Republic that had been prepared before the crisis started. The plan had been long overtaken by events. Clearly it no longer accommodated all of the circumstances affecting the Dominican situation, nor provided for appropriate courses of action to meet every contingency. It will be recalled that the range of eventualities that the original plan had foreseen included only three possible situations: 1) Trujillo overthrown and an acceptable provisional government established; 2) Trujillo overthrown but pro-Trujilloists or Castro/Communists seizing control, or a complete political collapse resulting in chaos; 3) Trujillo remaining in power indefinitely. The fact that none of these seemed to correspond very closely to whatever was the situation now confronting the U.S., or to take into account all of the various kinds of situations that might be encountered later, suggested a need for expanding the planning scope of anticipated directions in which the crisis could evolve and of the respective U.S. responses indicated. Therefore, the whole spectrum of contingencies and courses of action was reexamined.

^{1/} (S) Msg, Sec State to Ciudad Trujillo, 792, 062300Z Jun 61;
(OUO) Msg, Ciudad Trujillo to Sec State, 1348, 062300Z Jun 61.

186. The Consul General in Ciudad Trujillo was advised by the Secretary of State that the U.S. was in the process of updating and revising its Political Contingency Plan for the Dominican Republic in the light of recent developments by considering possible courses of action in response to specific situations. He was requested to comment on and make recommendations as to what in his view would be the indicated course of action in the following eventualities:

a. A pro-U.S. dissident group able to obtain a significant geographic base and form a plausible provisional government.

b. Consolidation of the Ramfis-Abbes-Espaila regime, currently in power, under the following conditions: a) moving toward rapprochement with the OAS and U.S.; b) continuing the same policies as the predecessor Trujillo regime; c) moving toward the Castro/Communist Bloc, either gradually or abruptly.

c. Internal dissension within the existing power structure developing in various forms, including a conflict between secret police and the military or a split within the military, either of which would lead to an outbreak of hostilities between opposing sides of the armed forces and probably result in a considerable degree of anarchy.

d. A move by Dominican security forces or some other group against the U.S. Consulate and individual U.S. nationals.

e. An overt armed attack on the Dominican Republic by Castro.

f. Gradual subversion of the Dominican Republic by Castro/Communist elements, either through agents moving in at the invitation of the existing regime or by the infiltration of agents without invitation.^{1/}

1/ (S) Msg, Sec State to Ciudad Trujillo, 776, 6 June 61.

187. Even the scope of this new list of six possible eventualities failed, however, to include the situation that was already revealing itself to be the one that actually obtained in the Dominican crisis.

POLITICAL FRAMES OF REFERENCE FOR MILITARY ACTION

188. An incidental but significant development occurred as a direct result of the above message regarding the updating of the Political Contingency Plan. The message had been repeated to COMSECONDFLT for information, and thereby he apparently first learned of the existence of a Political Contingency Plan. The next day, through his Political Adviser, he informed the Secretary of State that he did not have a copy of the plan referred to and requested, therefore, that a copy be sent him by air mail.^{1/} On 8 June the Secretary of State advised the Political Officer that a copy of the original Political Contingency Plan was being air mailed as requested.^{2/} Not only at this date was the providing of the political terms of reference within which the Senior Tactical Commander was to have conducted U.S. military operations somewhat late to be of much practical value, but in view of the message that had prompted COMSECONDFLT's request, the political plan that was furnished was already obsolete.

189. The matter of an adequate political frame of reference for COMSECONDFLT was brought up again late in the evening of 6 June. The Political Adviser to COMSECONDFLT sent a message to the Secretary of State, presumably at the behest of COMSECONDFLT, to register a protest (in which a note of exasperation can be detected) over the kind and quality of political information being provided by the State Department to the military commander. The

^{1/} (S) MSG, COMSECONDFLT POLAD (No. 11) to Sec State, et al., 071457Z Jun 61.

^{2/} (S) Msg, Sec State to COMSECONDFLT POLAD, 810, 8 Jun 61.

Political Adviser submitted a chronological description of the evolution of COMSECONDFLT's appraisal of current developments bearing upon the Dominican situation, in order to "...provide experience record useful to Dept in managing other operations." Included was a recapitulation of the political information available on which appraisal at each stage had been based. Citing messages and a HICOM call from the State Department Operations Center received on 5 June, he stated that COMSECONDFLT had inferred that the "Tenor of these appeared to reflect a policy of watchful waiting." The purport of later messages of 5 June then had led COMSECONDFLT to conclude that there was "...lack of disorder in Dominican Republic and firm control by Government..." Finally, COMSECONDFLT had received a subsequent State Department message on 6 June, "...which seemed to confirm policy of reserved judgment for the present."^{1/}

190. In short, COMSECONDFLT had been forced to collate, analyze, and interpret for himself the meaning and significance of information provided him by the State Department, both in regard to the political situation in the Dominican Republic and U.S. policy toward it, much as is normally done in the processing of raw, enemy intelligence indications. The message, as phrased, did not expressly require a response, and none apparently was made.

191. In another message the next day, the COMSECONDFLT Political Adviser apprised the Secretary of State of an incident that had occurred in connection with State Department messages. The Political Adviser stated that when COMSECONDFLT received the orders to move one destroyer just over the horizon off Ciudad Trujillo, three State Department messages had been cited as references:

^{1/} (S) Msg, COMSECONDFLT POLAD to Sec State, No. 10, 070249Z, Jun 61.

Ciudad Trujillo 1331, 1333, and 1334, the first a long message consisting of eight pages. The reference messages were consulted, whereupon COMSECONDFLT had requested the Political Adviser to prepare for him a memorandum giving the main points of the contents of these messages.^{1/}

192. Here an observation is in order concerning the general communicative capacity of the typical State Department message during the crisis. Whether originating in Washington or a diplomatic post abroad, and whether dealing with political intelligence or U.S. policy, the internal substantive content of State messages was frequently characterized by prolixity (without necessarily being a full development of the subject), ambiguity, a tendency to avoid predication, and a lack of systematic discursive organization. With regard to deficiency in composition, it may be noted that in some cases one can arbitrarily cut off and discard random portions of a message text, either at the beginning or end or from the middle, without experiencing any recognizable sense of loss in substance or coherence. As borne out so eloquently by the foregoing messages from COMSECONDFLT's Political Adviser, the information-transfer function of State Department communications was not always successful.

193. Despite the impressive volume of political message traffic that the crisis had occasioned up to now, there was an important area of tactically relevant political information requirements that at this late date still remained unfulfilled. The needed information had a direct, fundamental bearing on any military operation in the Dominican Republic.

1/ (S) Msg, COMSECONDFLT POLAD to Sec State (unnumbered), 080207Z Jun 61.

~~TOP SECRET~~

194. The Political Adviser to COMSECONDFLT, in a message to the Consul General in Ciudad Trujillo, requested detailed information concerning evacuation of U.S. nationals in case such an operation were required. Specifically, he wanted to know the location of concentration points, principal routes for evacuees, principal routes expected to be taken by any forces trying to prevent the evacuation, and whether evacuees would be escorted by Dominican police or the military. At the same time he also wished the names and probable political attitudes of Dominican military commanders in the Ciudad Trujillo area, particularly of the two battalions located at the airfield near the capital.^{1/}

195. A few hours later a somewhat related message, in certain respects, wider in scope, was sent by CINCLANTFLT to the District Intelligence Officer, 10th Naval District. Specific Order-of-Battle political intelligence was requested as to which Dominican military officers were anti-Ramfis, which were anti-SIM, which were anti-Balaguer, and which were anti-U.S., along with the rank, position, and influence of each. Also requested was information on the degree of anti-U.S. bias of Ramfis, as well as his attitude toward Abbes.^{2/}

196. No record has been found of a reply to either request for information. In view of the complexity and qualitative nature of the questions posed, and the time thus necessarily involved in providing answers, the operational need for such information may well have been overtaken by events long before all of the data could be compiled.

DECISION ANTICIPATED

197. In fact, it was late that very night (6 June) that a significant turning point in the crisis was marked by a proposal

^{1/} (S) Msg, COMSECONDFLT POLAD to Ciudad Trujillo (unnumbered), 061722Z Jun 61.

^{2/} (S) Msg, CINCLANTFLT to DIO, 10ND, 062100Z Jun 61.

~~TOP SECRET~~

~~TOP SECRET~~

initiated by COMSECONDFLT. It reflected, on the tactical military level, a sensing of the earlier noted political relaxing of the U.S. policy posture. COMSECONDFLT recommended to CINCLANTFLT that, in the event execution of contingency operations currently addressed to the Dominican situation were cancelled, the opportunity presented by the assembled naval forces be put to advantage by conducting a major Fleet exercise to test contingency plans, forces and preparations in general. He submitted for consideration an outline plan of the contemplated exercise.^{1/} The proposal proved to be well received and ultimately such an exercise culminated the military phase of the crisis.

198. June 7 saw a further ameliorating trend in the Dominican internal situation. The intelligence section of the Battle Staff Sit Rep that day described the capital as continuing quiet, with less public and military activity observed than usual, and the interior under control by Army troops and militia. Morale of both regular forces and militia was reportedly high, and there was no evidence of disloyalty to the regime.^{2/}

199. It was also on this day that the last important figure in the Trujillo assassination plot was found out and arrested by the regime, in the course of which more information was uncovered about the miscarriage of dissident plans. According to a naval intelligence report originating in San Juan, General Jose Roman, Secretary of State for Armed Forces and by the Constitution next in line of succession to the Presidency (there was no Vice President at the time), was to have been the key man in the plot. Trujillo's body was supposed to be delivered to him, whereupon he would take charge of the coup, supported by the military. But at the last

^{1/} (S) Msg, COMSECONDFLT to CINCLANTFLT, 070237Z Jun 61.
^{2/} (TS) J-3 Dominican Republic Sit Rep 7-61, 7 Jun 61.

minute Roman changed his mind and made himself unavailable. Thus, with the crucial link broken, connection could not be established between the assassins and the other two elements of the revolutionary group -- the dissidents and the military. As a result, no concerted uprising occurred as originally planned.^{1/} Only now had the Government learned of Roman's complicity, and he was jailed. The next day, by Presidential decree, he was removed as Secretary of State for Armed Forces.^{2/} Subsequently, further light was thrown on Roman's failure to carry out his assigned role, when it was revealed that at the critical moment he had been prevented from acting because of the chance discovery, by a Dominican security official, of the actual assassination in progress.^{3/} Later Roman confessed, was eventually tried on charges of treason, and sentenced to 30 years imprisonment.^{4/}

200. Not only did this new information explain the mysterious lack of any overt attempt by dissidents to seize power at the time of the assassination, and the consequent premature collapse of the coup even before it got started, but it established beyond doubt that the dissidents never had, and could not now have, any role in influencing the course of the crisis that they had brought about.

COMPLETION OF THE MILITARY BUILD-UP

201. Throughout the day of 7 June, final U.S. military preparations for contingency operations were nearing completion. Additional major amphibious elements and Fleet support units arriving from CONUS rendezvoused with the deployed naval force already on station, the last increment of the 4th Marine Expeditionary

1/ (S) Msg, COMCARIBSEAFRON to CNO, 072331Z Jun 61.
 2/ (S) J-3 Dominican Republic Sit Rep 9-61, 9 Jun 61.
 3/ (C) Msg, Ciudad Trujillo to Sec State, 1375, 10 Jun 61; New York Times, 12 Jun 61, p. 9; 13 Jun 61, p. 17.
 4/ (OUO) Msg, Ciudad Trujillo to Sec State, 1455, 18 Jun 61; New York Times, 18 Jun 61, p. 4; 22 Jun 61, p. 3.

~~TOP SECRET~~

Brigade joining the other Marine units the following day. The 19th Air Force established its advance headquarters at Ramey AFB. Also, a meeting of COMSECONDFLT/CJTF 122 with his Army and Air Force component task force commanders was held aboard his flagship to review plans and the status and capabilities of forces. As an outcome of the meeting, it was determined that all forces were ready to execute the Dominican contingency plan.^{1/}

202. Sometime around midday, the Chairman, JCS, met with the President at the White House. Briefing him on the military aspects of the Dominican situation, the Chairman outlined the U.S. military posture and its capabilities. Although a record of what transpired at the meeting is not available, it can be reliably inferred that no decision on a course of action was made, other than that no military action was to be taken at the present. When the Chairman returned from the White House and was debriefed, no requirements were placed on the Battle Staff as a result of the meeting.^{2/}

203. Late in the afternoon of 7 June the OAS Subcommittee Observer Team, composed of representatives of the U.S., Mexico, Uruguay, and Panama, arrived in Ciudad Trujillo with the mission of investigating conditions in the Dominican Republic, particularly charges of political repression and terrorism.^{3/} The U.S. Consul General, commenting on the Team's arrival the next day, reported that the Dominican Government made a display of being cordial and cooperative.^{4/}

204. It was thus, in such a context of political intelligence and changing policy views, that an evolving national decision on the U.S. military course of action in the crisis began to take form.

^{1/} (TS) Talking Paper for State-JCS Meeting - 9 June, prepared by Battle Staff, 8 Jun 61; (S) Msg, CINCLANTFLT to JCS, 072218Z Jun 61.

^{2/} (TS) JCS Dominican Republic Battle Staff Log.

^{3/} New York Times, 6 Jun 61, pp. 1,3; 8 Jun 61, pp. 1, 15.

^{4/} (OUO) Msg, Ciudad Trujillo to Sec State, 1353, 081600Z Jun 61.

~~TOP SECRET~~

DECISION AGAINST INTERVENTION

FINAL STRATEGIC ASSESSMENT

205. Through the next day, 8 June, again little change was noted in the Dominican internal situation, other than an apparent rapprochement between the Government and the Roman Catholic Church.^{1/}

206. However, a formal State Department-JCS meeting was called for 9 June. At JCS, this occasioned a fundamental review and consolidation of the whole intelligence picture of the Dominican situation. The Battle Staff, in the course of preparing a background briefing and position paper for the Joint Chiefs to use at the meeting, produced an outline statement of significant conclusions, interpretations, and estimates regarding the crisis.

207. In the resulting "Talking Paper," the Battle Staff assessment of the situation was as follows:

- a. Ramfis at present was in control, with apparently no one inclined to challenge him for the time being.
- b. In an effort to cultivate a favorable image and minimize criticism, the regime claimed adherence to democratic principle and was restraining repressive measures of internal security forces.
- c. There was nothing to indicate that any dissident action against the regime had occurred in the capital or in the interior, or that any such action was likely to be taken in the immediate future.
- d. On the contrary, there was no evidence of the existence of a dissident group of sufficient strength and organization to be capable of taking effective anti-government action.

^{1/} (TS) J-3 Dominican Republic Sit Rep E-61, 6 June 1961.

e. Although there was a "good possibility" of dissension developing within the ranks of the Ramfis-controlled clique, with other Trujilloists vying for political power, it was considered unlikely that prodemocratic dissident elements could successfully exploit such dissension to wrest control unless the internecine competition degenerated into an all-out power struggle.^{1/} As was to become evident the next day, the State Department apparently arrived at a substantially similar assessment of the Dominican situation.

208. Also included in the talking paper was a list of unresolved politico-military operational issues. It stated that U.S. forces were prepared to execute planned military operations. However, prior to implementation of a decision to intervene, the following policy questions bearing directly on the tactical conduct of operations should be resolved:

- a. Was the Dominican Republic to be warned of U.S. intent?
- b. Would U.S. air units launch strikes against the Dominican Republic Air Force immediately upon the order to execute the CINCLANT Operation Plan?
- c. What were the rules of engagement governing U.S. forces en route to the objective area in the event of attack by Cuban aircraft?

A further discussion of background details concerning the foregoing policy questions was presented separately to the JCS in an oral briefing by one of the Battle Staff members.^{2/}

209. Within the Dominican Republic, the OAS Observer Team commenced its investigative activities. U.S. policy had set great

1/ (TS) Talking Paper for the JCS for the State-JCS Meeting, 9 June, prepared by Battle Staff, 8 June 1961.
2/ Ibid.

store by the presence of OAS observers in the country. It was the U.S., in fact, that had instigated the sending of the OAS Team. Now that they were there the Secretary of State even felt safe to advise the COMSECONDFLT Political Adviser that, in the absence of a Castro move or extreme deterioration of the Dominican situation, no "show of force" was indicated pending results of the OAS group's efforts.^{1/} But already a note of reservation about the prospects of the OAS investigation was beginning to creep in.

210. The U.S. was apprehensive lest some of the Latin-American members of the OAS Team only superficially go through the motions of conducting a nominal investigation. The Secretary of State conveyed the U.S. fears in this regard in a message to the Consul General in Ciudad Trujillo. He stated the U.S. policy position as viewing the continued presence in the Dominican Republic of the OAS Observer Team over a sustained period to be essential to a satisfactory resolution of the crisis. The U.S. was therefore concerned over the possibility that the OAS Team might depart prematurely.^{2/} As if to lend basis to U.S. suspicions, the next day the Consul General reported that during the initial interviews by the OAS group on 8 June the sincerity and cooperative attitude demonstrated by the Dominican President and Foreign Minister had made a favorable impression on most of the Team members. Later, even Ramfis himself favorably impressed them.^{3/}

THE OFFICIAL DECISION

211. June 9 was formally the day of decision for the U.S. regarding the Dominican Republic crisis. Actually the decision had been progressively emerging de facto in U.S. actions over the preceding several days. Now it was articulated institutionally as a deliberate official act in its own right.

- ^{1/} (S) Msg., Sec. State to COMSECONDFLT POLAD, 810, 6 June 1961.
^{2/} (C) Msg., Sec. State to Ciudad Trujillo, 809, 6 June 61.
^{3/} (S) Msg., Ciudad Trujillo to Sec. State, 1364, 092000Z Jun 61; New York Times, 9 June 61, p. 10; (OUO) Msg., Ciudad Trujillo to Sec. State, 1379, 11 June 61.

212. The scheduled State-JCS meeting was held that morning to consider the crisis situation and determine what appropriate U.S. military course was indicated. The State Department appreciation of the situation was that tension in the Dominican Republic was fading out. Accordingly, its position was that there was no further need to maintain the present U.S. military readiness posture. It was prepared, thus, to see U.S. military operations addressed to the Dominican situation unwind. The JCS concurred in the State Department appreciation and its position on military readiness requirements. It was therefore agreed that the level of U.S. military readiness posture be reduced. As a precaution, however, the readiness posture would not be relaxed at once, nor completely, but withdrawal of forces phased so as to permit timely resumption of adequate readiness if any change in the situation so warranted. Before the meeting ended the Chief of Naval Operations broached the subject of possibly wanting to hold an operational exercise prior to withdrawing forces, a proposal first made by COMSECOND-FLT on 6 June. The State Department saw no objection in doing so.^{1/}

213. Command action required to implement the decision on military posture reached at the State-JCS meeting occupied the next several hours. The Vice Director, Joint Staff, directed the Battle Staff to draft a message to CINCLANT requesting his recommendations for reducing readiness posture. The Chairman, JCS, upon reviewing the draft, had the message changed to the extent of directing CINCLANT to do so. After it was approved by the JCS, the Chairman then took up the substance of the message with the Secretary of Defense. Finally, upon being cleared by both the Secretary of Defense and the Secretary of State, the message was sent to CINCLANT that evening.^{2/}

^{1/} (TS) JCS Dominican Republic Battle Staff Log.
^{2/} Ibid.

214. In the message, the Chairman, JCS, apprised CINCLANT of the State Department's appraisal of the Dominican situation, and advised him that, since the prospects of a U.S. decision to intervene had lessened, immediate execution of the CINCLANT contingency plan for the Dominican Republic would not be required. He therefore instructed CINCLANT to decrease the overall readiness posture of his command, but retain a relatively small, amphibious force in the Dominican Republic area ready for instant reaction, if needed, with the balance of the forces on 72-hour reaction time.^{1/}

215. Implicit in the particular decision that had been made was a larger, more generic decision of national policy that finally bowed to the inevitable and readjusted U.S. objectives accordingly. The former operating premises of U.S. strategy in a Dominican crisis, which had been laid down in the National Security Council meeting of 5 May 1961 and codified in the Political Contingency Plan resulting therefrom, had anticipated contingencies that did not occur and prescribed courses of action that were not applicable. Rather than being any one of the three clear-cut eventualities that had been projected, the actual situation confronting the U.S. had turned out to be an unexpected bastardized one.

216. Indeed, Trujillo had been removed. But the feared Castro/Communist attempt to exploit the opportunity presented thereby had not materialized, nor had the U.S.-sponsored dissident movement been able to assert itself even to the extent of providing a legalistic pretext for U.S. armed forces to intervene and install it in power. Instead, the same legal government of President Balaguer that had been in existence previously under Trujillo had remained in power, with an indeterminate degree of Trujilloist influence, but was passing itself off, with some

1/ (S) MSG, OJCS 997370 to CINCLANT, 092314Z Jun 61.

~~TOP SECRET~~

success, as being a regime of different character than that under Trujillo. Moreover, it was demonstrating, at least outwardly, a transition toward the kind of government the U.S. professedly wished to see in power.

217. In these circumstances, the new U.S. policy orientation reflected in the State-JCS decision of 9 June had settled on the following objectives:

- a. Support the Balaguer Government
- b. Prevail upon it to divest itself of Trujilloist influences.
- c. Persuade it to adopt democratic reforms.

IMPLEMENTING THE DECISION

218. Well before the Chairman's message ordering reduction of military readiness was released and transmitted, the CINCLANT staff had informally indicated that CINCLANT expected to dispatch a message to JCS recommending a combined airborne-amphibious exercise be held to test [] ^{1/}

This was a direct follow-up of COMSECONDFLT's original proposal to CINCLANT of 6 June. Early the same evening, the message was sent. CINCLANT requested JCS to authorize an exercise to test contingency plans, now that developments in the Dominican situation warranted relaxation in reaction time of deployed U.S. forces. The contemplated exercise was described in outline. ^{2/}

219. The next day, 10 June, intelligence noted no significant change in the situation in the Dominican Republic, and the various steps involved in reduction of military readiness posture proceeded to be carried out.

-
- 1/ (TS) JCS Dominican Republic Battle Staff Log.
 - 2/ (S) Msg, CINCLANT to JCS, 091939Z Jun 61.
 - 3/ (TS) JCS Dominican Republic Sit Rep 10-31, 10 June 1961.

220. In the morning, CINCARIB advised JCS that forces of his command reverted from DEFCON 4 to DEFCON 5 at 1500Z hours.^{1/} Two hours later, CINCLANTFLT informed COMSECONDFLT (et al.) that he had established DEFCON status for LANTFLT forces as follows:

- a. DEFCON 3 for Naval Task Fleet 120 (same as formerly).
- b. DEFCON 4 for Caribbean Sea Frontier.
- c. DEFCON 5 for the remainder of LANTFLT.^{2/}

221. Shortly thereafter, CINCLANT advised JCS that, in response to their instructions contained in JCS 997370 of the previous day he had directed one PHIBRON (with embarked Marine BLT), plus one destroyer division and one minesweeper division, to remain in the Dominican Republic vicinity, while the remainder of the Naval Task Fleet 120 units were to move out to prepare for participation in the test exercise.^{3/}

222. In the afternoon, JCS instructions were also prepared by the Battle Staff to reduce readiness of Army and Air Force units to 72-hour reaction time. But because of some reservations as to whether this was consistent with the alert status of DEFCON 4 and 5 then still in effect, the sending of the instructions was deferred until 12 June, when it was postponed again, to be sent on 13 June. Similarly, a draft message was prepared by the Battle Staff indicating favorable JCS response to the proposed test exercise, but despite clearance by the Chairman, JCS, final decision to approve the exercise was deferred until 12 June, but only to be postponed and not actually sent until 13 June.^{4/}

223. Little of significance to the crisis occurred on June 11, a Sunday. The Battle Staff Sit Rep for that day had no new

1/ (C) Msg, CINCARIB to JCS, 101517Z Jun 61.
 2/ (S) Msg, CINCLANTFLT to COMSECONDFLT et al., 101705Z Jun 61.
 3/ (S) Msg, CINCLANT to JCS, 101753Z Jun 61.
 4/ (TS) JCS Dominican Republic Battle Staff Log.

developments to report either in the Dominican situation or U.S. actions related to it.^{1/} The only item of note was a report from the Consul General in Ciudad Trujillo that Ramfis, in his interview by the OAS Observer Team, had apparently managed to give the members a favorable impression of both himself and the state of affairs.^{2/}

DEPARTURE OF OAS OBSERVERS

224. The situation in the Dominican Republic remained basically unchanged thereafter. The Consulate reported on 12 June that while SIM agents were being furloughed, it was reliably known that Ramfis was developing a new intelligence-security organization based in the Air Force to take the place of SIM. Reports also came in to the effect that many prisoners held by the Government had been transferred to outlying towns in order to preclude their discovery by the OAS Observer Team, with whom the regime was being otherwise cooperative.^{3/}

225. A serious development occurred that day, however, in connection with the OAS Observer Team. As the U.S. had feared, several members of the Team, on the grounds that the investigation was nearing completion, proposed recess and departure from the Dominican Republic on 15 June.^{4/}

226. Alarmed, the Secretary of State the next day instructed the U.S. Representative on the Team, and the Consul General in Ciudad Trujillo as well, to try to persuade the other members that it was essential for them to remain in the Dominican Republic long enough to reach definitive conclusions about the political state of affairs of the country. The U.S. simultaneously

1/ (TS) J-3 Dominican Republic Sit Rep 11-61, 11 Jun 61.
2/ (CUO) Msg, Ciudad Trujillo to Sec State, 1379, 11 Jun 61.
3/ (S) J-3 Dominican Republic Sit Rep 12-61, 12 Jun 61
4/ (C) Msg, Ciudad Trujillo to Sec State, 1390, 12 Jun 61.

instructed U.S. Ambassadors concerned to take up the matter directly with the home governments of the other nations represented on the OAS Team.^{1/} Both the U.S. Representative and the Consul General approached individual members and tried to prevail upon them that all or part of the Team should remain longer,^{2/} but to no avail. It became clear the following day that their intended departure reflected foregone policy decisions of their respective governments.

227. The Consul General then recommended to the Secretary of State that, in order to offset the effects of the imminent departure of the OAS Team, the U.S. issue an official statement reiterating its continuing interest in the Dominican situation. The Consul General's reasoning was that such a statement would help allay fears among the opposition of renewed reprisals, and might even encourage those elements within the regime who sincerely wanted to pursue a policy of moderation.^{3/} Appropriate statements were duly issued, and just before the OAS Team left on 15 June, the Secretary of State instructed the U.S. Representative to urge the Team to make known to the Dominican authorities its intention to keep under observation the treatment subsequently accorded persons it had interviewed.^{4/}

228. The "precipitate" departure of the OAS Observer Team, as it was referred to in a subsequent State Department circular message, was a disappointing set-back for U.S. policy.^{5/} The Team's findings proved even worse. (See par. 237.)

1/ (C) Msgs, Sec State to Ciudad Trujillo for Drew (U.S. Rep., OAS Subcmte Obs Gp) and Circulars 2007 and 2010, Jun 61.
2/ (C) Msg, Ciudad Trujillo to Sec State, 1402, 14 Jun 61.
3/ (C) Msg, Ciudad Trujillo to Sec State, 1416, 14 Jun 61.
4/ (C) Msg, Sec State to Ciudad Trujillo for Drew, 821, 15 Jun 61.
5/ (C) State Department Circular 2031, 15 Jun 61..

REDUCING MILITARY READINESS POSTUREEXERCISE AXLE GREASE

229. At the JCS meeting on the morning of 12 June the matter of the proposed test exercise was taken under consideration. It was decided to authorize CINCLANT to conduct the exercise, but with certain restrictions over what had been requested. The holding of a live amphibious exercise involving only naval forces earmarked for contingency operations, plus a CPX involving only commanders and staffs of the other earmarked forces, was approved. No actual CONARC or TAC forces would participate.

230. That afternoon the Deputy Director, J-3, coordinated the policy details of the exercise with the Military Assistant to the President at the White House, and was advised to insure that if the exercise took place the Dominican Government be informed so there would be no invasion scare. The Battle-Staff-prepared JCS message authorizing the exercise was checked with the Vice Director Joint Staff, who in turn cleared it with the Chairman, JCS. The Chairman then directed that it first be coordinated with CINCLANT in order to find out whether he would still be willing to hold the exercise as approved by JCS. The contents of the message were relayed informally to the CINCLANT staff by voice-scrambler telephone and the response indicated that CINCLANT was emphatic in desiring the exercise; in anticipation of approval CINCLANT had already directed COMSECONDFLT to carry out D-day-minus-3 preparatory actions with naval forces. Prompt JCS approval of the exercise was requested.

231. Next morning, 13 June, the Chairman, JCS, decided to clear the approval message with both the Secretary of Defense and the President before releasing it. By the time such clearance was obtained and the message was

finally released, it was late evening. At 2000 hours the Battle Staff informally transmitted in advance the text of the message authorizing the exercise by voice-scrambler telephone. Shortly thereafter, the official message was formally transmitted through regular channels.^{1/} In the message JCS authorized CINCLANT to conduct a CPX with the commanders and staff of all Service component forces earmarked for contingency operations in the Dominican Republic, and to conduct simultaneously a live training exercise only with naval forces so earmarked. The nickname AXLE GREASE was assigned for this exercise.^{2/}

FURTHER REDUCTION OF READINESS

232. By 13 June the Dominican internal situation had clearly stabilized for the time being. The Battle Staff Sit Rep noted again, as throughout the previous week, no significant change. Militarily, the crisis seemed to be drawing to a close. CINCLANT even desired the one remaining Marine BLT left on station off the Dominican coast to be included among the other naval units participating in Exercise AXLE GREASE, but on the recommendation of the Vice Director, Joint Staff, he agreed to leave it in position as a precautionary measure. Otherwise, all naval forces that had been deployed were moved to the Culebra-Vieques area of Puerto Rico.^{3/}

233. In view of the declining operational aspects of the crisis, the Director, Joint Staff, authorized the Battle Staff to reduce on-duty coverage to a period from 0700 hours in the morning until the time the J-3 Directorate normally secures for the evening, with one officer to be on telephone call at night. The daily J-3 Sit Rep was also discontinued effective with the 13 June

^{1/} (TS) JCS Dominican Republic Battle Staff Log.
^{2/} (S) Msg, JCS 997514 to CINCLANT, 140022Z Jun 61.
^{3/} (S) J-3 Dominican Republic Sit Rep 13-61, 13 Jun 61; (TS) JCS Dominican Republic Battle Staff Log.

~~TOP SECRET~~
issue; in its place a weekly Sit Rep would be published each Friday beginning 16 June.^{1/}

234. That afternoon CINCLANT proposed to JCS that, if circumstances warranted, there be a further decrease in readiness posture on or about 17 June. He recommended that it take the following form:

a. All Caribbean contingency naval forces be put on DEFCON 4.

b. Naval Task Fleet 120 be deactivated and units return to CONUS.

c. The amphibious squadron, with embarked Marine BLT and supporting destroyers and minesweepers, be retained in the Caribbean area.

d. Army and Navy components of JTF 122 be placed on DEFCON 5.^{2/}

Earlier in the day the Director of Operations, Air Force Headquarters, had requested of the Director, J-3, that the Air Force units be immediately returned to DEFCON 5.

235. The Battle Staff prepared a draft JCS message approving CINCLANT's recommendations, which was referred through the Deputy Director, J-3, to the Vice Director, Joint Staff. The following day the Vice Director discussed the contemplated further reduction of force readiness with the Director of the State Department Operations Center, while the Deputy Director, J-3, discussed it with the Military Assistant to the President. In both cases no objection was voiced, the Presidential Military Assistant even indicating that in his opinion approval by the President was not required. The Chairman, JCS, however, decided to clear the proposal with the Secretary of Defense and the

1/ (TS) JCS Dominican Republic Battle Staff Log.
2/ (S) Msg, CINCLANT to JCS, 132126Z Jun 61.

~~TOP SECRET~~

~~TOP SECRET~~

President. After this was accomplished, the JCS message authorizing reduction of force readiness status was released, and at 1845 hours dispatched for transmission to CINCLANT, Chief of Staff, Army, and Chief of Staff, Air Force.^{1/} A day later (16 June) the Army and Air Force units earmarked for] were put on DEFCON 5 by their respective Services, and the day following, on 17 June, all LANTCOM forces also went on DEFCON 5, with the exception of the contingency force remaining in the Caribbean, which was kept on DEFCON 4.^{2/}

236. Reflecting the degree of passive calm to which the Dominican situation had subsided, the U.S. Consul General in Ciudad Trujillo on 14 June reported receiving two notes, both dated 12 June, through the British Embassy, in which the Government of the Dominican Republic alleged that Dominican airspace had been violated in two instances on 3 June by U.S. aircraft. The tone of the charges in each case was "quite restrained."^{3/} The Consul General also relayed unverified reports of a rift developing within the Trujillo family, with many of its members preparing to depart.^{4/}

OAS OBSERVER TEAM FINDINGS

237. Offsetting these generally favorable indications, as far as U.S. policy was concerned, was the public disclosure of preliminary findings of the OAS Observer Team. Much as had been feared by the U.S., on the eve of its departure the Team members revealed that the investigation found the country peaceful and orderly, with no evidence of police abuses, and that important

- ^{1/} (TS) JCS Dominican Republic Battle Staff Log; (S) Msg, JCS (number unknown) to CINCLANT, C/SA, C/S USAF (Approx. 2345Z) 15 Jun 61.
- ^{2/} (S) Msg, DA 997681 to CGUSCONARC, et al., 1602130Z Jun 61;
(C) Msg, CINCLANT to JCS 171217Z Jun 61.
- ^{3/} (C) Msg, Ciudad Trujillo to Sec State, 1400, 14 Jun 61.
- ^{4/} (C) Msg, Ciudad Trujillo to Sec State, 1400, 14 Jun 61.

political reforms had been noted in recent days.^{1/} U.S. spokesmen criticized the findings the following day, but the final report submitted by the Team to the OAS on 18 July was essentially the same as what had been announced on 14 June.

1/ (U) New York Times, 15 Jun 61, p. 2.

END OF THE MILITARY PHASE OF THE CRISIS

238. Exercise AXLE GREASE was conducted by CINCLANT on 16 June in the Vieques-Culebra area of Puerto Rico as planned, and terminated on 17 June. The Dominican situation still remained dormant.^{1/}

239. As the exercise ended and the bulk of U.S. forces that had been marshalled for operations in the Dominican Republic left for home, an anticlimatic touch, not without pathos, was added to the crisis. As the last vestigial trace of what had originally set in motion momentous events, it was the final gesture of a long lost cause on which so much hope had once been placed and so much enterprise expended. On 17 June, dissident leaders approached an official of the U.S. Consulate in Ciudad Trujillo and once again pleaded for U.S. armed intervention. They proposed a plan to create an excuse for such intervention by staging provocative acts, such as sabotaging American property and investments and threatening the safety of American citizens, thus leaving the U.S. no alternative but to intervene. The Consular official to whom it was proposed rejected the plan outright as "utter stupidity" and forcefully advised the dissidents to abandon the whole scheme.^{2/}

240. The next day, 18 June, the Consul General submitted to the Secretary of State a review and evaluation of developments in the Dominican crisis, identifying what he believed to be the principal trends indicated that had policy significance for the U.S.

241. The internal political situation, he felt, was one of cautious waiting on the part of both the dissident opposition and

1/ (S) J-3 Dominican Republic Sit Rep 14-61, 16 Jun 61.

2/ (S) Msg, Ciudad Trujillo to Sec State, 1451, 17 Jun 61.

~~TOP SECRET~~

the Government, with neither desiring to take precipitous action for the time being. Law and order was being maintained, with no sign of unrest. The regime gave no evidence of pro-Castro or Communist orientation, and its attitude toward the U.S. remained ambivalent although not anti-American.

242. Civilian dissident groups were, in his opinion, without esprit and impotent, while exile groups had insufficient domestic support. The military establishment seemed to be still consolidated and responsive to Ramfis' command. Balaguer was probably well-intentioned, but his position was weak so long as Trujilloists continued in control of the military, the security services, and important segments of the economy. Within the Trujillo family complex, indications were that strains had begun to develop and friction in relations between members might lead to serious clashes.^{1/}

243. It was on 19 June, 21 days after the assassination of Trujillo, that the military phase of the Dominican Republic crisis formally came to a close. The Dominican Republic Battle Staff of JCS, after having been in existence for 19 days, was disestablished and publication of the Dominican Republic Sit Rep was discontinued. At 1700 hours that evening the last Battle Staff watch was secured, with a final entry to this effect made in the Battle Staff Log.^{2/}

244. The political phase of the crisis, however, continued for some time longer. In the course of reaching a climax, before a measure of stability was regained, it assumed again a military phase briefly and U.S. forces once more had a role

^{1/} (C) Msg, Ciudad Trujillo to Sec State, 1454, 18 Jun 61.
^{2/} (S) Memo, Dir J/S to J-3 et al., DJSM-712-61, 19 Jun 61;
(TS) JCS Dominican Republic Battle Staff Log.

in influencing the outcome. Late in November two show-of-force operations were conducted: SEA BULL, a demonstration by U.S. naval surface vessels offshore within view of Ciudad Trujillo and other ports, and WAVE HIGH, a fly-by of Marine aircraft. But a Joint Battle Staff was not reactivated for the occasion. Except for a four-day period when the J-3 Commands Division was set up just short of Battle Staff status and operated out of the JWR Battle Staff room, what would have been Battle Staff functions were performed in the course of regular activities by the J-3 Divisions normally concerned, in coordination with other interested JCS Directorates. Political unrest in the Dominican Republic, marked by outbreaks of violence and disorder, carried over into the next year, coming to a head with a military coup on 16 January 1962, followed two days later by a countercoup on 18 January, then gradually subsided until a tenuous semblance of order was restored. A year after the Trujillo assassination the internal situation was still smoldering.

RECAPITULATION

245. A number of general observations about decision making in command and control of the U.S. response to the crisis that were brought out in the foregoing analysis bear summarizing and reemphasis.

246. The Dominican crisis was from the beginning, and remained, essentially political. It never had intrinsically a military dimension, other than that which was misread into it by some agencies of the U.S. Government. Nevertheless, it was a classic example of the use of force as a policy instrument. The U.S. military response was addressed to a political condition, rather than a military situation, and the strategic objectives it was intended to serve were accordingly political in nature and for a policy purpose. However, no clearly defined "enemy," against whom force would be employed, was identified, initially or later, and in a relatively short period of time the original "friendly forces" (the dissidents) were replaced by new ones (the Government) to whom political support was extended and military support promised.

247. The peak of intensity of the military phase of the crisis, as interpreted and reacted by the U.S., occurred at the beginning (31 May - 1 June) and progressively declined thereafter. (See Figure 1). Conversely, the national decision against intervention was not a climactic discrete event but an evolving process. It gradually emerged and took form de facto over a period of time (7 days) before it was institutionally adopted as a formal decision and given official sanction.

248. Political intelligence proved to be the overriding problem of command and control, before and during the crisis. Defense-State coordination and prior planning had been more fully

~~TOP SECRET~~

accomplished prior to this crisis than ever before and State-Defense cooperation throughout the event was more effective than ever before. Despite this, the political intelligence system had been unable to perceive the nature of the crisis or isolate the critical factors in it in pace with the speed of events and the concomitant urgency of decision requirements. Before the crisis, strategic political intelligence on which policy and planning had been based was faulty: the character of the coming crisis had been wrongly surmised; the capabilities of the dissidents, miscalculated; and the resourcefulness and stability of the Government, misjudged. During the crisis, tactical political intelligence had been inadequate to the needs of command and control, both political and military, for day-to-day decisions in the management of U.S. action: at times, the salient features of the current internal political situation within the Dominican Republic were unknown, confused, or erroneous; at other times, when known correctly, were learned too late. By default, in the absence of reliable and timely political intelligence, operating premises for decisions were almost exclusively dependent upon past assumptions, policies, and objectives as stipulated in plans, sometimes with little relationship to contemporary circumstances.

249. Besides the lack of adequate political intelligence, a major constraint upon command and control was the built-in constraint of plans, particularly the Political Contingency Plan. The combination of preciseness but incompleteness represented in its limited spectrum of anticipated contingencies and alternative options tended to truncate arbitrarily the range of choice permitted decision makers, until the deficiency was discovered and additional possibilities considered. The rigidity and inertia of precommitment in the form of a plan had, in this case, the effect of inhibiting both flexibility and speed of response.

~~TOP SECRET~~

250. Military response, once committed to a course of action, is, because of its mass, inherently less flexible than political response, which it follows and to which it is functionally subordinate. There was thus, in the Dominican crisis, a time lag before the military course of action under way could be altered in compliance with a change in political objectives. In view of the radical degree of change of political objectives experienced during the crisis, the military response (in the form of force deployment in preparation for intervention) proved to be out of phase shortly after it was initiated and required some 10 days before being brought back again into phase with policy. The time lag was directly proportionate to the mass and momentum of the military commitment.

251. Of special significance to military command and control is that U.S. decision behavior in the Dominican Republic crisis manifested a pronounced tendency toward elevation of tactical issues into strategic issues and a resulting centralization of military operational decision making at the seat-of-government level. Many issues that, in themselves, were technically only minor military concerns were frequently seen as threshold acts potentially constituting a national commitment of policy implications or strategic consequences. The degree of caution exercised in this regard accounts for the instances of such issues being preempted and resolved as national decisions.

252. Politico-military operational issues also ended up as strategic issues. Because of no coordination or decision-making machinery being provided for on lower echelons of authority, wherever political factors impinged upon military operational considerations the problem was invariably referred upward, to be dealt with by national decision makers. In view of the brevity of the military phase of the crisis, the decision time delay

involved often prevented decisions on these issues from being rendered in time to be of utility or relevance in meeting the operational requirements that raised them.

253. Central to and determining on U.S. command and control throughout the Dominican Republic crisis were the nonmilitary aspects of decision making. Among these, the most crucial was political intelligence. In the final sense, only political intelligence can provide the basis for discriminate decisions to effect optimum military response in a predominantly political context.

FIGURE 1
CHRONOLOGY OF SIGNIFICANT EVENTS

CHRONOLOGY OF SIGNIFICANT EVENTS

1961

- 1 Jun (~0800) JCS Dominican Republic Battle Staff becomes operational.
- 1 Jun (~1030) JCS meeting decides to augment contingency forces, doubles strength.
- 2 Jun (~1700) Letter requesting U.S. intervention received from General Estrella.
- 2 Jun (2330) State-Defense meeting decides not to respond to Estrella request.
- 3 Jun Consul General reports reign of terror in Dominican Republic.
- 4 Jun Consul General offers Balaguer U.S. military support.
- 5 Jun Consul General recalled.
- 6 Jun Venezuela advises against military intervention.
- 6 Jun (~1900) State Dept. meeting decides no immediate U.S. military action to be taken.
- 7 Jun Arrival of OAS Observers in Dominican Republic.
- 7 Jun (2137) COMSECONDFLT proposes holding training exercise.
- 9 Jun State-JCS meeting decides to reduce U.S. military readiness posture.
- 12 Jun JCS meeting decides to authorize training exercise.
- 15 Jun OAS Observers leave Dominican Republic.
- 16-17 Jun Exercise AXLE GREASE conducted.
- 17 Jun Deployed Naval units begin return to CONUS.
- 19 Jun JCS Dominican Republic Battle Staff dis-established.

~~SECRET~~

FIGURE 1

1, ATCH B

clean

~~TOP SECRET~~

INVENTORY OCT 21 1968

Copy of 15 copies

Each of 214 sheets

OFFICE OF THE DIRECTOR OF DEFENSE RESEARCH AND ENGINEERING
WEAPONS SYSTEMS EVALUATION GROUP
WASHINGTON 25, D.C.

RETIREMENT COPY

1967

CI # 1

ATTACHMENT "B"

A FUNCTIONAL ANALYSIS OF JOINT STAFF INVOLVEMENT IN
THE JUNE 1961 DOMINICAN REPUBLIC CRISIS

25 September 1962

INVENTORIED
APR 14 1969

INVENTORY FEB 10 1975

SPECIAL HANDLING REQUIRED

~~NOT RELEASABLE TO FOREIGN NATIONALS~~

The information contained in the attached document will not be ~~disclosed to foreign nationals~~ without the express approval of the head of the originating office. Approval shall refer specifically to this document or to specific information contained therein.

Reproduction of this document in whole or in part is prohibited except with permission of the issuing office.

INVENTORIED

THIS DOCUMENT AS A WHOLE IS CLASSIFIED ~~TOP SECRET~~
INDIVIDUAL PORTIONS AND ATTACHMENTS HERETO
CARRY THEIR APPROPRIATE CLASSIFICATION.

INVENTORY JAN 20 1972

GROUP - 1
EXCLUDED FROM AUTOMATIC
DOWNGRADING AND DECLASSIFICATION

LIMITED DISTRIBUTION

OASD(PA) DFOISR

81-TS-141 (2)

R-5

80F-01997

DOC 3 CS-JCS/DOC DIU

CY R-3

~~TOP SECRET~~

FOI 637A

INVENTORIED

Log No. TS-62-453

095144

224

ATTACHMENT "B"
A FUNCTIONAL ANALYSIS OF JOINT STAFF INVOLVEMENT IN
THE JUNE 1961 DOMINICAN REPUBLIC CRISIS

TABLE OF CONTENTS

	<u>Page No.</u>
INTRODUCTION	1
STUDY PURPOSE	1
DATA SOURCES UTILIZED	1
SCOPE AND METHOD OF PRESENTATION	2
THE ROLE OF THE JOINT STAFF	3
FUNCTIONS IN NATIONAL MILITARY AND POLITICAL POLICY DEVELOPMENT -- OPERATIONS BY THE JCS AND UPPER ECHELONS OF THE JOINT STAFF	3
FUNCTIONS IN SUPPORT OF THE JCS -- OPERATIONS BY THE JOINT BATTLE STAFF AND JOINT STAFF DIRECTORATES	5
PRIMARY JOINT STAFF ACTIONS DURING THE CRISIS	12
ACTIONS STUDIED	12
ANALYTICAL APPROACH	14
TIME REQUIREMENTS FOR JOINT STAFF ACTIONS	16
GENERATION OF REQUIREMENTS INFORMATION FOR JOINT STAFF ACTION	18
ESTABLISHMENT OF REQUIREMENTS IN THE JOINT STAFF AND APPROVAL OF ACTIONS RECOMMENDED	20
ACTION ASSIGNMENTS - DEVELOPMENT OF DRAFT ACTION RECOMMENDATIONS	24
INFORMATION FLOW	27
TELEGRAPHIC MESSAGE TRAFFIC	27
Scope and Method of Analysis -- Summary of Telegraphic Message Traffic -- Military-In Messages - JCS Direct Addressee -- Military-In Messages - Info Copies to JCS -- State-In Messages -- State-Out Messages -- JCS-Out Messages	
INFORMAL JOINT BATTLE STAFF COMMUNICATIONS	41
JBS Telephone Conversations -- JBS Conferences, Meetings and Briefings -- JBS Personal Contacts	

TABLE OF CONTENTS (CONT'D)

	<u>Page No.</u>
FINDINGS AND SUMMATION	45
OBSERVATIONS AND RECOMMENDATIONS OF THE DOMINICAN REPUBLIC JOINT BATTLE STAFF	45
CONCLUDING OBSERVATIONS	47
With Regard to the Role of the Joint Staff -- With Regard to Functions Required for Joint Staff Actions -- With Regard to Data Sources and Information Flow	
ADDITIONAL RESEARCH SUGGESTED	50

TABLES

TABLE I	- SUMMARY OF CONFERENCES AND MEETINGS AT ECHELONS HIGHER THAN THE JOINT BATTLE STAFF	4
TABLE II	- SUMMARY OF RECORDED JBS DAILY ACTIVITIES	10
TABLE III	- SUMMARY OF JCS-OUT MESSAGES AND FUNC- TIONAL RESPONSIBILITIES	13
TABLE IV	- TIME FOR FUNCTIONS INVOLVED IN JOINT STAFF ACTIONS RESULTING IN JCS-OUT MESSAGES	17
TABLE V	- GENERATION OF REQUIREMENT INFORMATION FOR JCS-OUT MESSAGES	19
TABLE VI	- REQUIREMENT ESTABLISHMENT AND ACTION APPROVAL PHASES FOR DOMINICAN REPUBLIC JCS-OUT MESSAGE ACTIONS	22
TABLE VII	- DEVELOPMENT OF JOINT STAFF DRAFT ACTION RECOMMENDATIONS FOR JCS-OUT MESSAGES	25
TABLE VIII	- SUMMARY OF TELEGRAPHIC MESSAGES IN- COMING TO JBS	29
TABLE IX	- IN-MESSAGES SUMMARY	30
TABLE X	- MILITARY IN JCS DIRECT ADDRESSEE	32
TABLE XI	- MILITARY-IN - INFO COPIES	34
TABLE XII	- STATE-IN MESSAGES	35
TABLE XIII	- STATE-OUT MESSAGES	38
TABLE XIV	- JCS-OUT MESSAGES	39

TABLE OF CONTENTS (CONT'D)

Page No.

TABLE XV	- SUMMARY OF RECORDED JBS PHONE CON- VERSATIONS FROM 31 MAY THROUGH 17 JUNE, 1961	42
TABLE XVI	- JBS CONFERENCES AND MEETINGS	43
TABLE XVII	- JBS PERSONAL CONTACTS OF RECORD	44

FIGURES

FIGURES 1 THROUGH 18	- JBS DAILY ACTIVITIES (31 MAY 1961 THROUGH 17 JUNE 1961)	6
----------------------	--	---

APPENDICES

APPENDIX "A"	- CHRONOLOGICAL LISTING OF RECORDED CONFERENCES AND MEETINGS AT ECHELONS HIGHER THAN JBS CONCERNED WITH DOMINICAN REPUBLIC CRISIS	52
APPENDIX "B"	- RECORD OF ACTIONS RELATED TO JCS-OUTGOING MESSAGES	59
APPENDIX "C"	- INFORMAL JBS COMMUNICATIONS	151

~~TOP SECRET~~

ATTACHMENT "B"

A FUNCTIONAL ANALYSIS OF JOINT STAFF INVOLVEMENT IN
THE JUNE 1961 DOMINICAN REPUBLIC CRISIS

INTRODUCTION

STUDY PURPOSE

1. This is a presentation of the results of a functional analysis of the records compiled by the May-June 1961 Dominican Republic Joint Battle Staff (DR JBS). The purpose of this paper is to present a record of the functions performed in the Joint Staff and the information flow to, from and between Joint Staff offices, in enough detail to allow Joint Staff interpretation as to adequacy and timeliness.

2. Interpretations as to adequacy and timeliness of functions performed and information flow will require development of criteria for evaluation. This paper presents the empirical evidence of the functions, information and time required for the DR crisis actions taken by the Joint Staff, but does not attempt to establish criteria for their evaluation. It is hoped that the collated data presented in this study can assist in determining what may be reasonable criteria for evaluating Joint Staff actions.

DATA SOURCES UTILIZED

3. Research to date has involved examination of message files, logs, notes and information products of the DR JBS, related JCS papers, and interviews with members of the JBS. Message files consist of Military-In, Military-Out, State-In and State-Out telegrams obtained by the JBS from the Joint Message Center and from JBS members' respective Service contact points (e.g., Navy Flag Plot files). JBS logs and notes consist of records of phone calls, telecons, personal visits and conversations, conferences and briefings of which JBS members were informed.

~~TOP SECRET~~

~~TOP SECRET~~

~~TOP SECRET~~

4. The primary limitation on pertinent information available appears to be lack of data as to actions at the general officer level. Relationships between general officers and the Battle Staff seem to be recorded on most occasions, as are top echelon conferences resulting in requirements for JBS action. Coordination effected at the general officer level in clearing or approving actions originated by the JBS are not deducible from records about half the time, and detailed notes of upper echelon conferences have not been available. Secondary limitations on data developed include absence of comprehensive information as to the role of J-2 and other intelligence offices, and unavailability of personal knowledge of officers who have left the Joint Staff.

SCOPE AND METHOD OF PRESENTATION

5. The main body of the study consists of three sections, examining first the functions performed in the Joint Staff, second the primary actions taken by the Joint Staff during the crisis, and third, the information flow to, from and between Joint Staff offices. The first section, "The Role of the Joint Staff," reviews the operations of the JCS and upper echelons of the Joint Staff (as the guiding force behind all subordinate functions), and then analyzes in detail the operations of the Joint Battle Staff and the Joint Staff directorates. The second section examines in detail the functions performed and interrelationships involved in generating the 29 JCS-Out messages transmitted during the crisis. The third section, concerning information flow, consists of a traffic analysis of telegrams in the JBS message file, and an analysis of the informal communications revolving around the DR JBS. Finally, some conclusions are made as to more interesting observations developed and as to potential uses of this paper, and the Joint Battle Staff's own critique of its operations is reviewed.

~~TOP SECRET~~

~~TOP SECRET~~

6. In line with the basic purpose of this study, being the presentation of data in a form suitable for interpretation, analyses have consisted primarily of data presentations designed to answer specific questions about Joint Staff functions, actions and information flow. Although all tables are addressed to some specific questions (e.g., how was an action requirement initially recognized, when, and by whom?), there are usually many other questions to which the same data are applicable. Because of the difficulty of anticipating the key questions, answers to which may be desired for evaluation, much of the basic data are included in appendices to the study in collated form amenable to many other interpretative analyses.

THE ROLE OF THE JOINT STAFF

FUNCTIONS IN NATIONAL MILITARY AND POLITICAL POLICY DEVELOPMENT-- OPERATIONS BY THE JCS AND UPPER ECHELONS OF THE JOINT STAFF

7. Although appraisal of the role of the JCS was not a purpose of the functional analysis of the Dominican Republic crisis, it was found necessary to consider their role carefully in relation to subordinate echelon functions. What types of decisions and what specific actions are passed on from the JCS to higher echelons, and what requirements for lower echelon functions are passed down from higher echelons, determine very largely what is done throughout the Joint Staff, and as a corollary, determine the information flow.

8. Records available of conferences and meetings at echelons higher than the JCS are listed chronologically in Appendix "A." For each day of the crisis period, each type of meeting is noted, and participants are listed when it is not obvious who was in attendance. The purpose of the meeting and/or DR subjects discussed, and the results of the meeting, are briefly described. If a JCS member was present at a meeting it is so indicated; if

~~TOP SECRET~~

~~TOP SECRET~~

~~TOP SECRET~~

not, the source from which the JBS received its information, when known, is listed. Miscellaneous pertinent notes are recorded in the Remarks column.

9. Table I is a summary of the data in Appendix "A" concerning conferences and meetings of echelons higher than the JBS. It will be noted that the JCS and Ops Deps meetings are greatest in number, but that the JBS apparently received no briefings on eleven of them. These eleven meetings, plus one SecDef-JCS meeting, were listed in the JCS agenda as taking place. It may be assumed that the JBS was given any pertinent data resulting from these meetings. However, with no specific reference being made to them in the records, it was not possible to connect them to subsequent actions.

TABLE I
SUMMARY OF CONFERENCES AND MEETINGS AT ECHELONS
HIGHER THAN THE JOINT BATTLE STAFF

<u>Type of Meeting</u>	<u>Number of Meetings</u>	<u>Number on Which JBS was Briefed</u>
Total:	30	18
JCS	13	7
Ops Deps	7	2
State-Defense	5	5
SecDef-JCS	2	1
State	1	1
White House-CJCS	1	1
White House-JBS	1	1

10. Of the eighteen meetings for which there is a JBS record of the outcome, seven were attended by JBS members. Information on seven of the remaining eleven was received from the Vice Director, J/S.

~~TOP SECRET~~

~~TOP SECRET~~

11. The State-Defense meetings were primarily policy-making meetings to provide guidance for CINCLANT in implementing the Contingency Plan. Decisions were based on the intelligence picture plus Joint Staff briefings on military posture. The JCS and Ops Deps meetings were held often to review DR planning and to make decisions on military support and operations. From 12 June, meetings were primarily concerned with the reduction of the readiness status of forces and plans for a test exercise.

FUNCTIONS IN SUPPORT OF THE JCS -- OPERATIONS BY THE JOINT BATTLE STAFF AND JOINT STAFF DIRECTORATES

12. A basic purpose of a Joint Battle Staff is to represent the Joint Staff in miniature; to provide for rapid staffing of actions in a crisis situation where time may be critical. The June 1961 DR JBS initially consisted of three members from J-3 and one from each of the other directorates. Actually J-1, J-5 and J-6 representatives had no occasion to serve with the JBS after the first day, and J-2 and J-4 members spent most of their time in their own offices. The J-3 members assigned to the JBS were the officers with normal noncrisis functional responsibilities for the crisis area. As a result, all J-3 functions were handled as part of the JBS internal operations, while most of the J-2 and the J-4 staff work was done away from the JBS area. Accordingly, records of the Joint Staff actions coordinated by the JBS are much more complete for J-3 than for other directorates' operations.

13. Day-by-day accounts of activities of the JBS during the Dominican Republic crisis situation have been charted in Figures 1 through 18. Specifically, each chart portrays the following:

a. Message flow into the JBS: including source of message, communication method utilized, the type or nature of the message, and the time received by the JBS.

~~TOP SECRET~~

~~TOP SECRET~~

~~TOP SECRET~~

FIGURES 1 THROUGH 18
JBS DAILY ACTIVITIES
(31 MAY 1961 THROUGH 17 JUNE 1961)

~~TOP SECRET~~

~~TOP SECRET~~

8-11-62-1
~~TOP SECRET~~

JBS DAILY ACTIVITIES - 31 MAY 1961

TIME (2400 TO 1200)

□ TELEPHONE
○ TELEGRAPH
◇ HAND CARRIED

△ PERSONAL CONVERSATION
--- JCS ACTION MESSAGE UNDER CONSIDERATION
..... RELATED ACTIVITIES

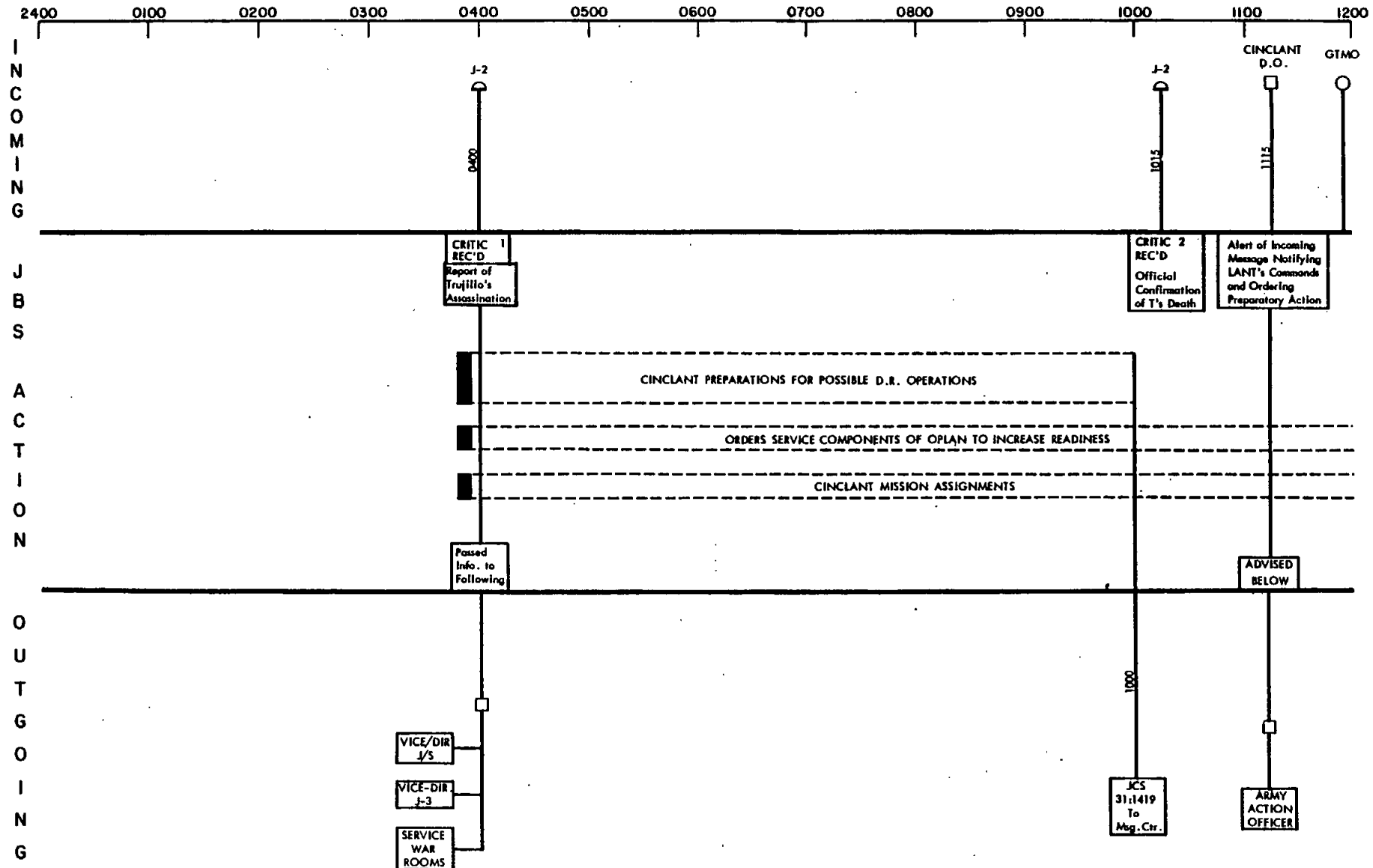

FIGURE 1A

~~TOP SECRET~~

JBS DAILY ACTIVITIES - 31 MAY 1961

TIME (1200 TO 2400)

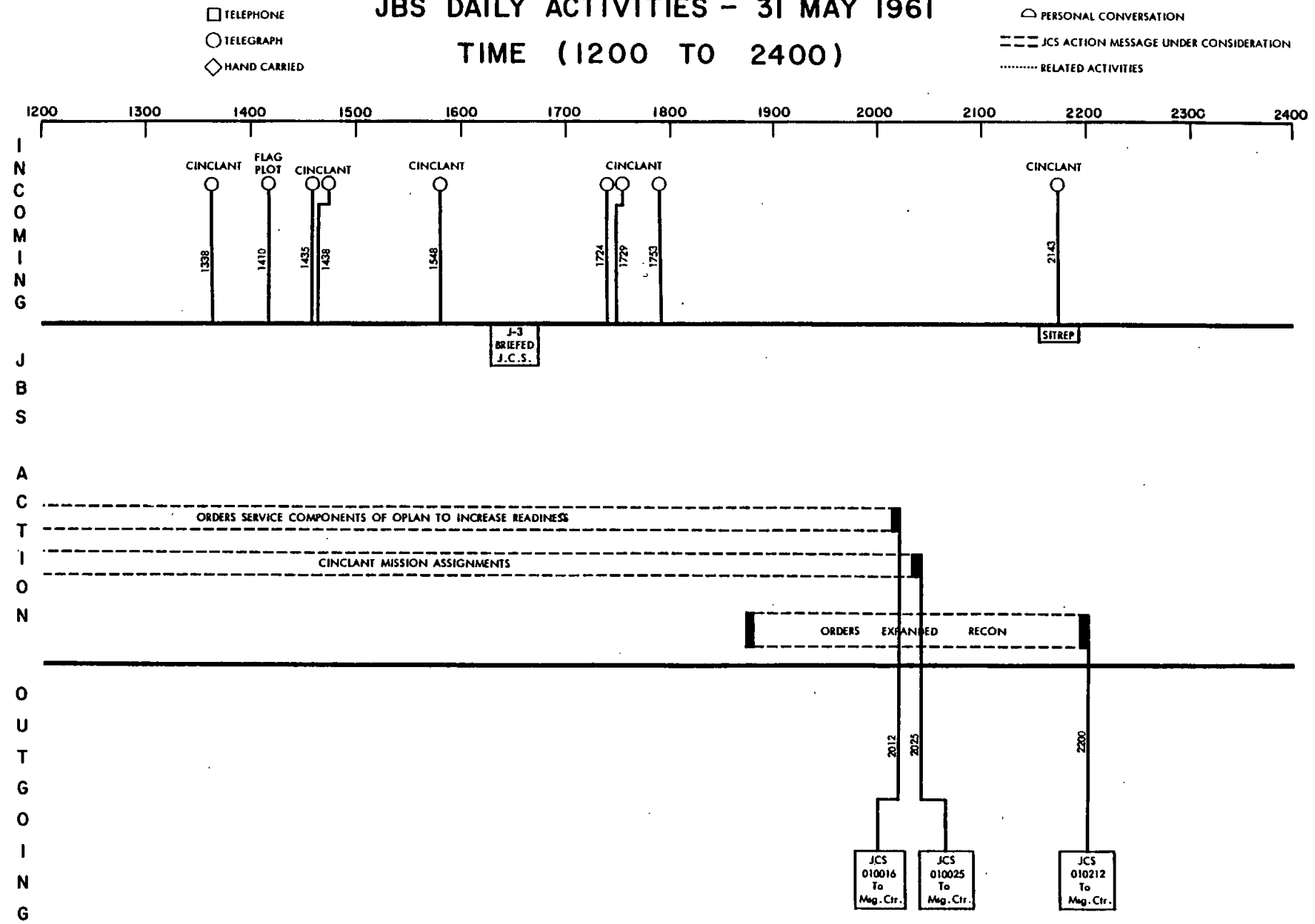

FIGURE 1B

TOP SECRET

8-11-62-3

TOP SECRET

JBS DAILY ACTIVITIES - 1 JUNE 1961 TIME (2400 TO 1200)

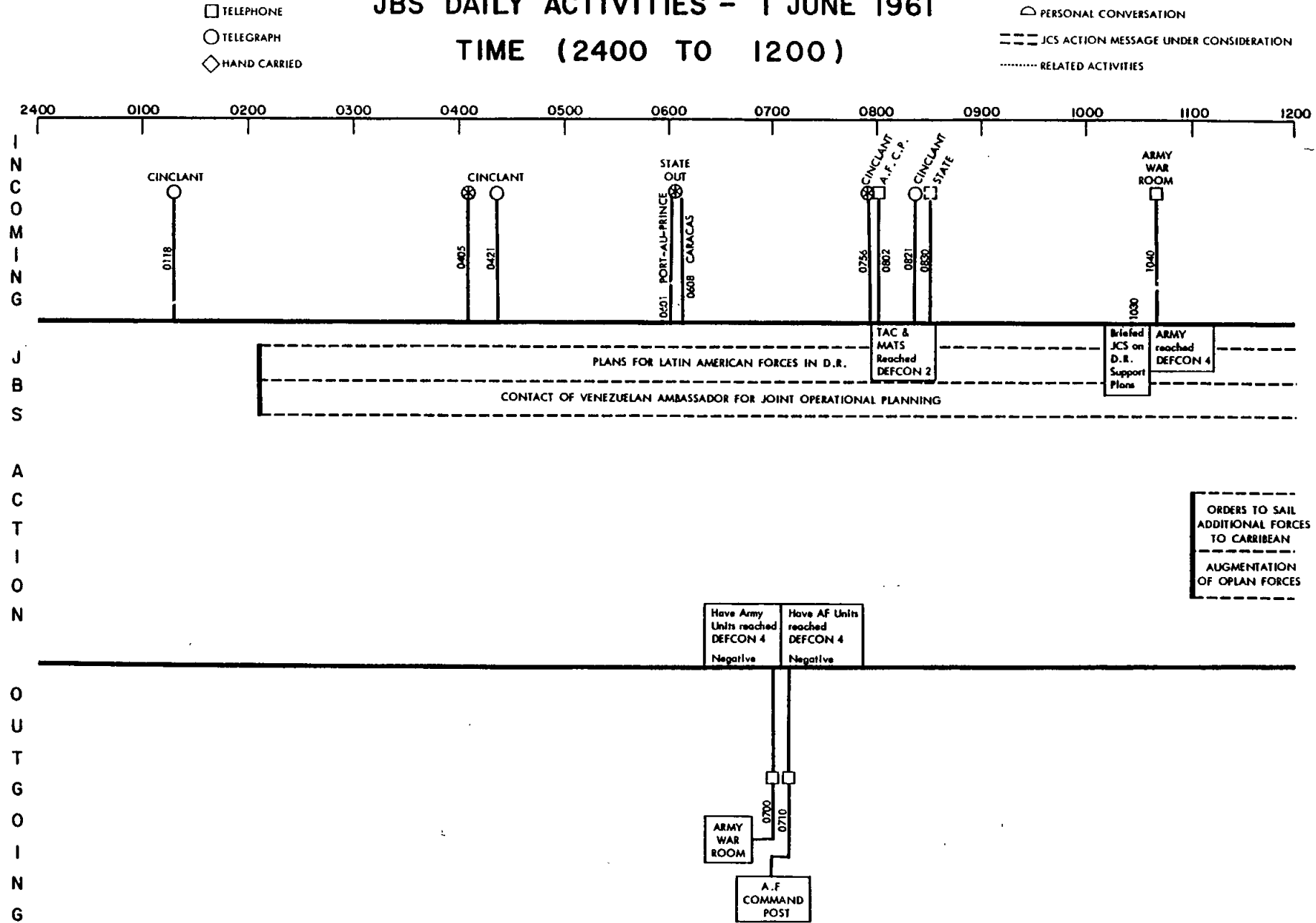

FIGURE 2A

8-11-62-4
TOP SECRET

JBS DAILY ACTIVITIES - 1 JUNE 1961

TIME (1200 TO 2400)

□ TELEPHONE
○ TELEGRAPH
◇ HAND CARRIED

○ PERSONAL CONVERSATION
--- JCS ACTION MESSAGE UNDER CONSIDERATION
..... RELATED ACTIVITIES

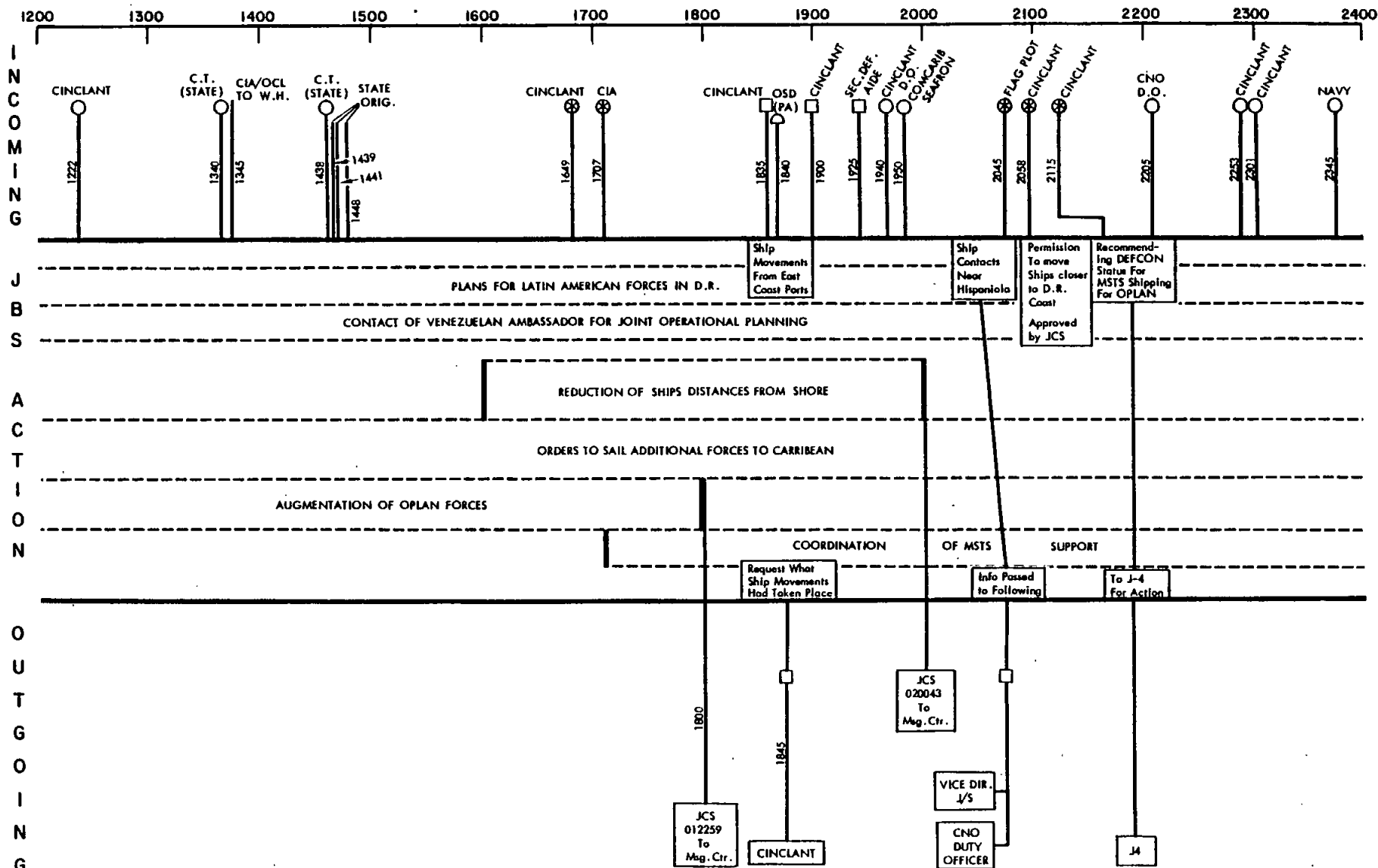

TOP SECRET

FIGURE 28

8-11-62-5

TOP SECRET

TOP SECRET

JBS DAILY ACTIVITIES - 2 JUNE 1961 TIME (2400 TO 1200)

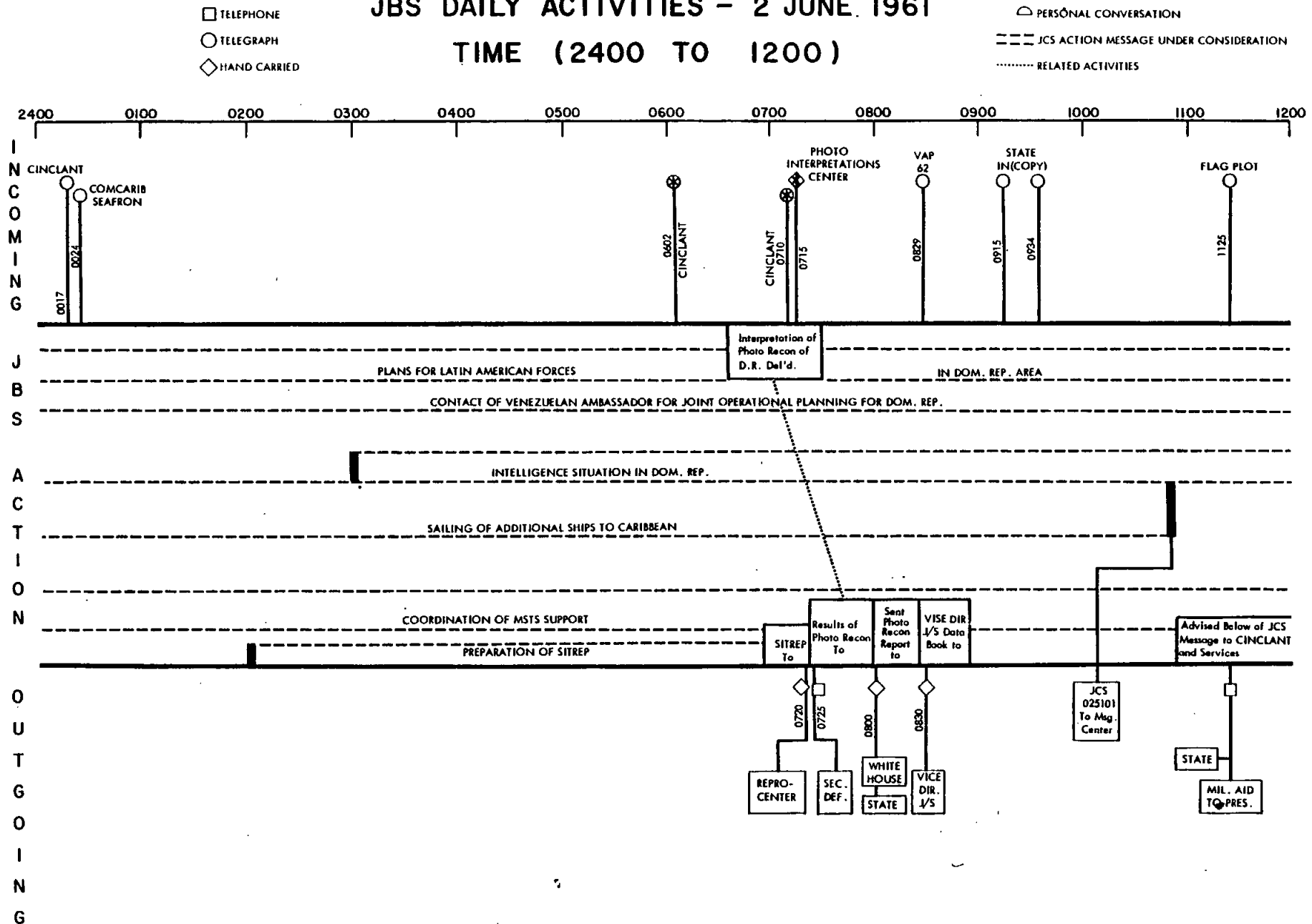

FIGURE 3A

TOP SECRET

8-11-62-6

TOP SECRET

JBS DAILY ACTIVITIES - 2 JUNE 1961 TIME (1200 TO 2400)

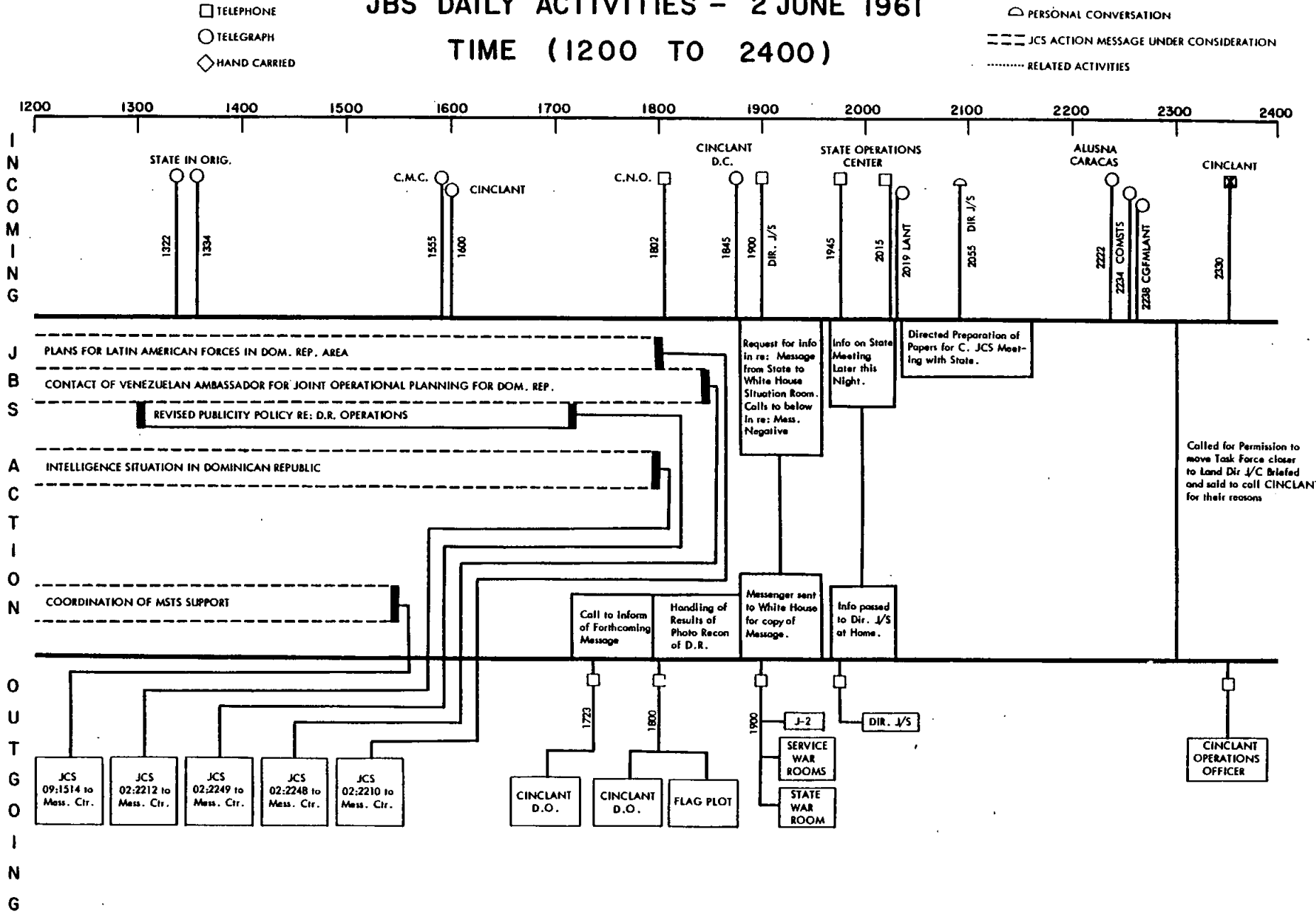

FIGURE 3B

TOP SECRET

8-11-62-7

TOP SECRET

JBS DAILY ACTIVITIES - 3 JUNE 1961 TIME (2400 TO 1200)

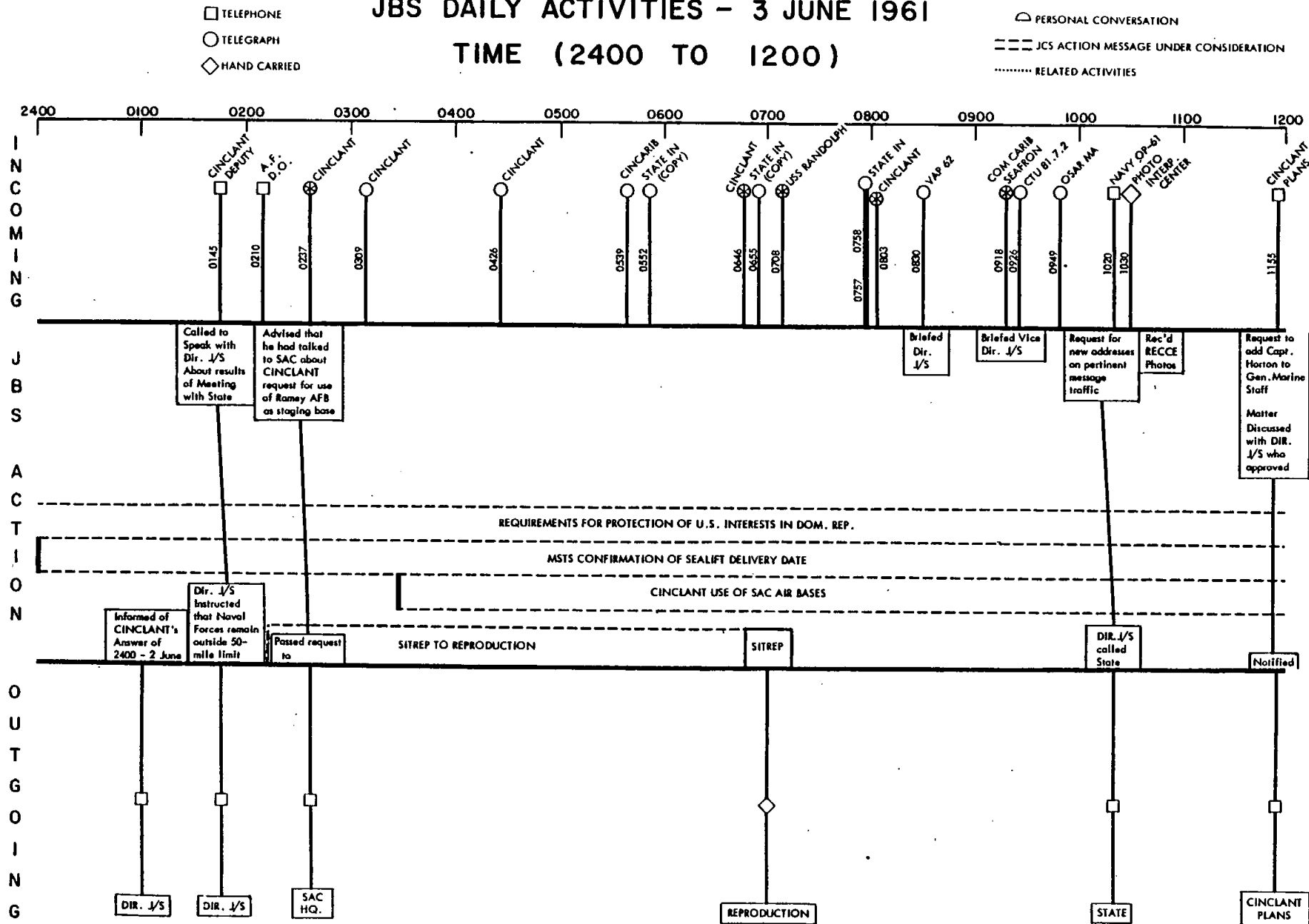

FIGURE 4A

JBS DAILY ACTIVITIES - 3 JUNE 1961

TIME (1200 TO 2400)

□ TELEPHONE
○ TELEGRAPH
◇ HAND CARRIED

△ PERSONAL CONVERSATION
--- JCS ACTION MESSAGE UNDER CONSIDERATION
..... RELATED ACTIVITIES

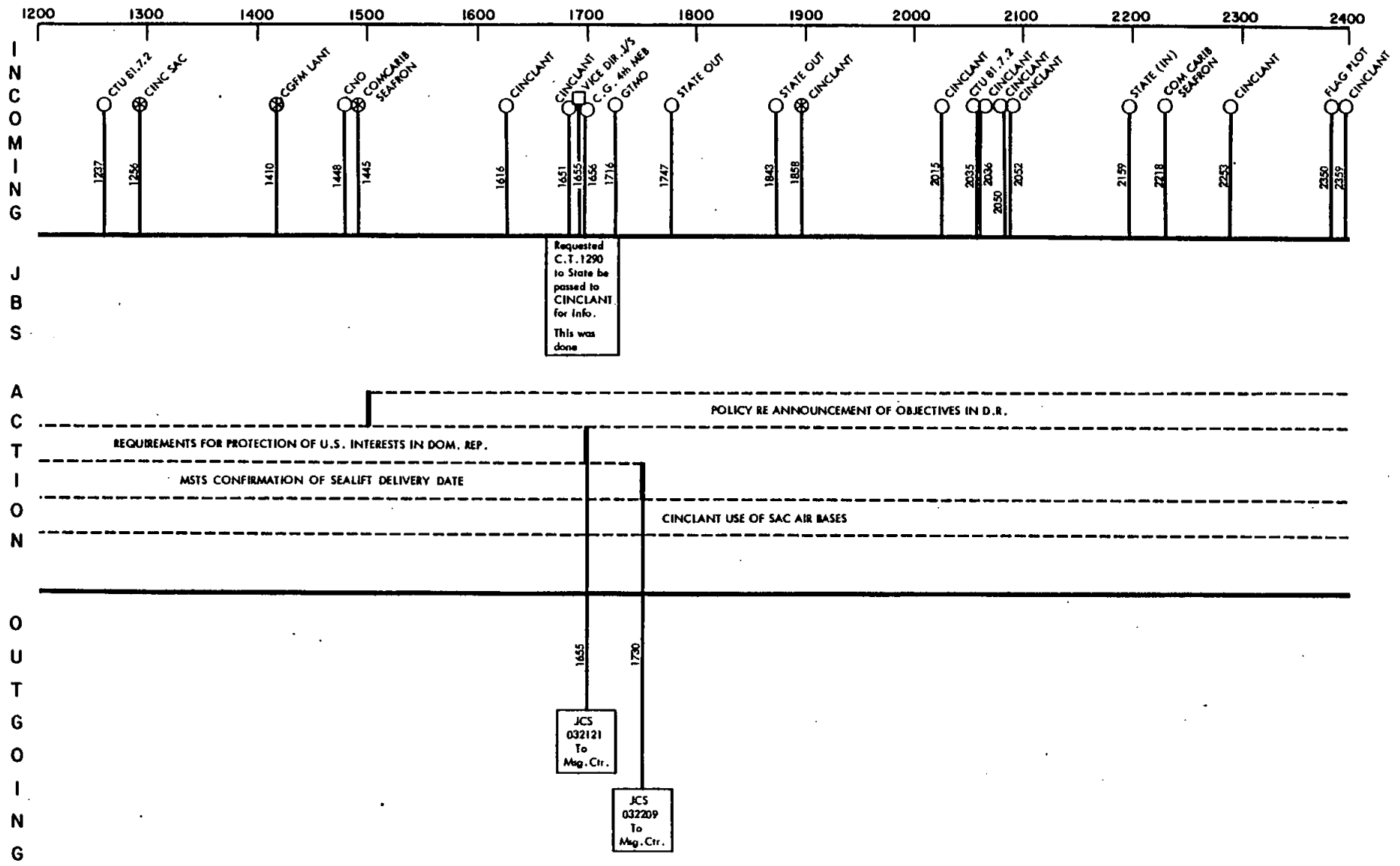

FIGURE 4B

8-11-62-9

TOP SECRET

TOP SECRET

JBS DAILY ACTIVITIES - 4 JUNE 1961 TIME (2400 TO 1200)

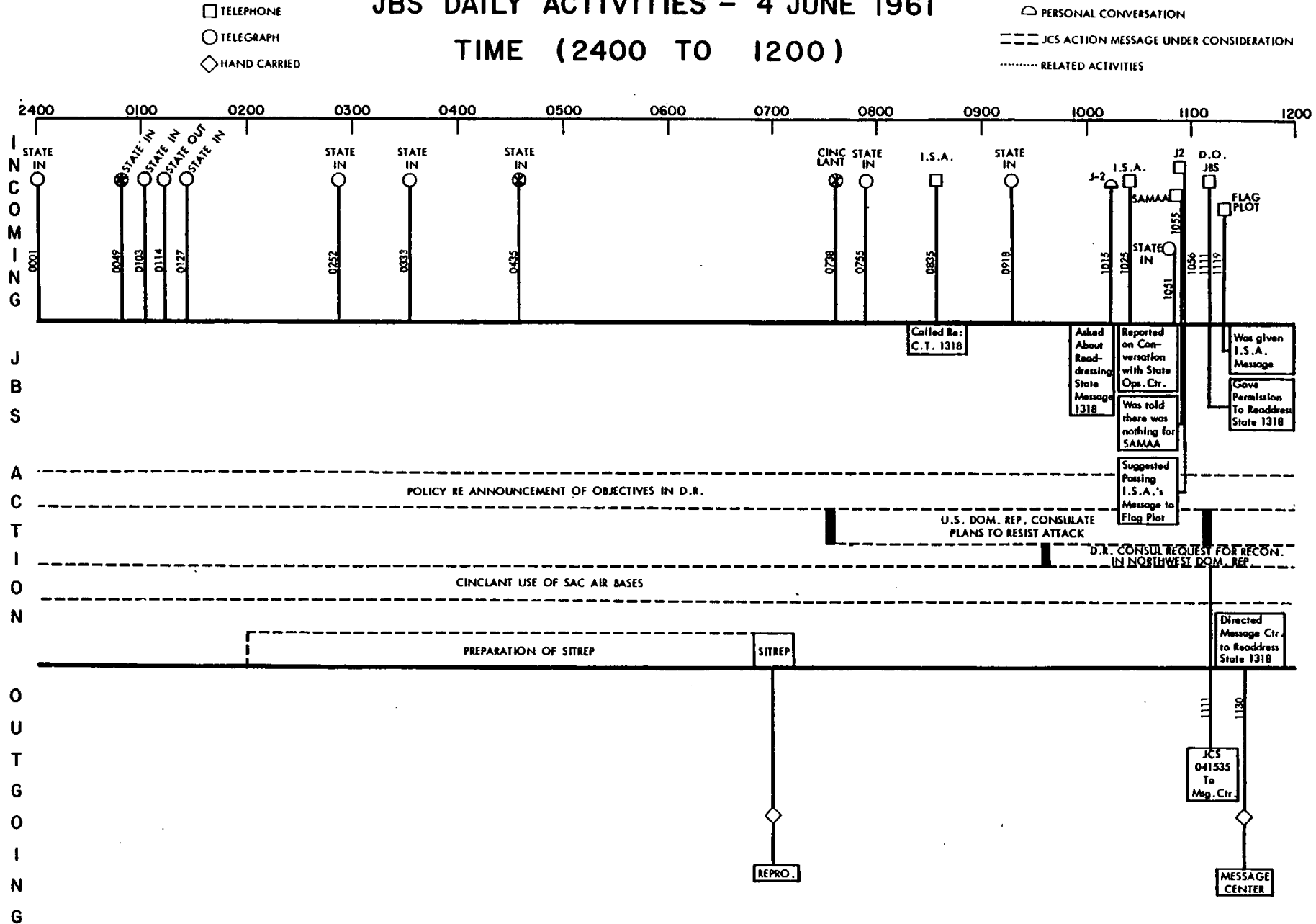

FIGURE 5A

JBS DAILY ACTIVITIES - 4 JUNE 1961 TIME (1200 TO 2400)

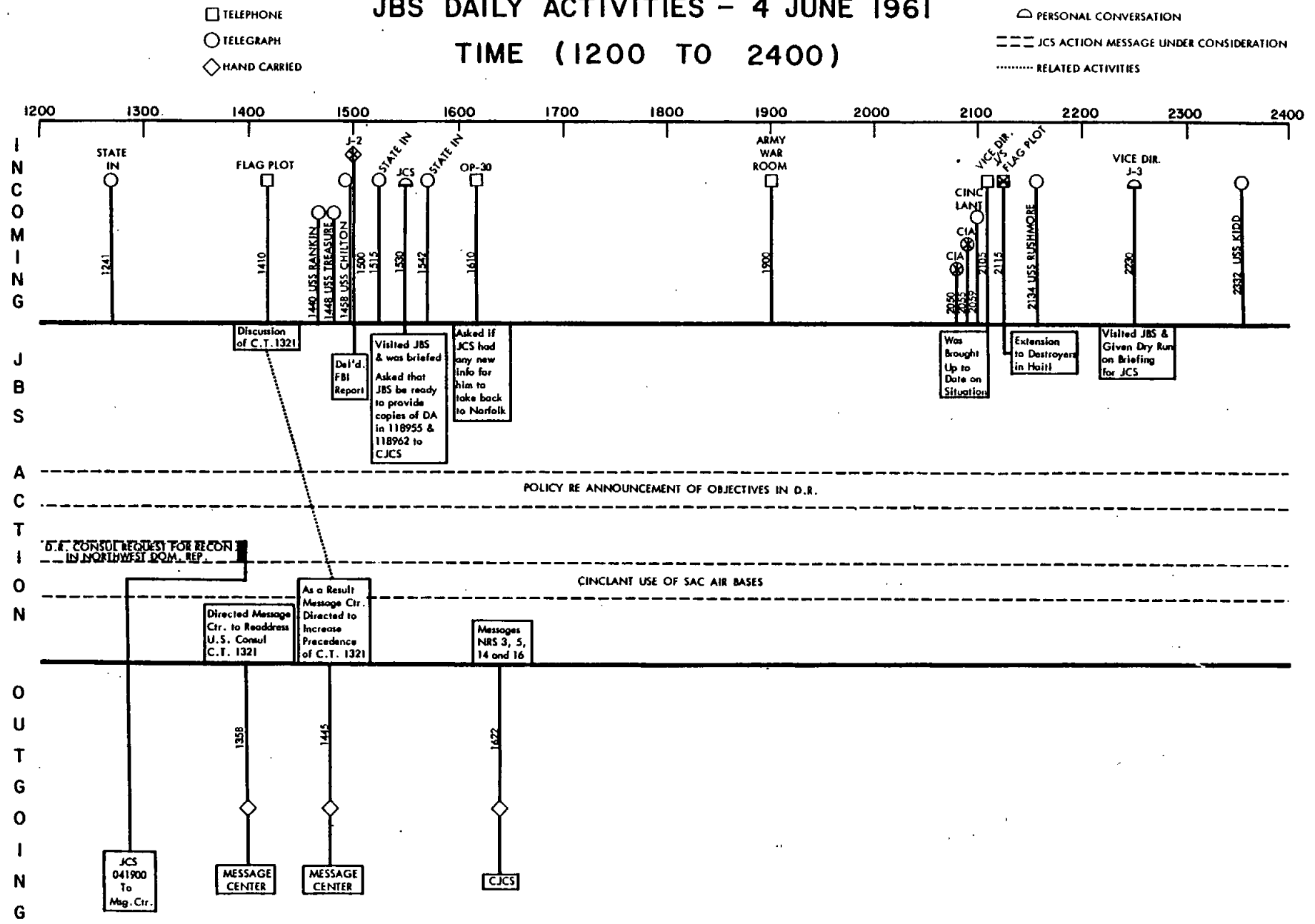

FIGURE 5B

8-11-62-11
~~TOP SECRET~~

~~TOP SECRET~~

JBS DAILY ACTIVITIES - 5 JUNE 1961

TIME (2400 TO 1200)

□ TELEPHONE
○ TELEGRAPH
◇ HAND CARRIED

△ PERSONAL CONVERSATION
- - - JCS ACTION MESSAGE UNDER CONSIDERATION
..... RELATED ACTIVITIES

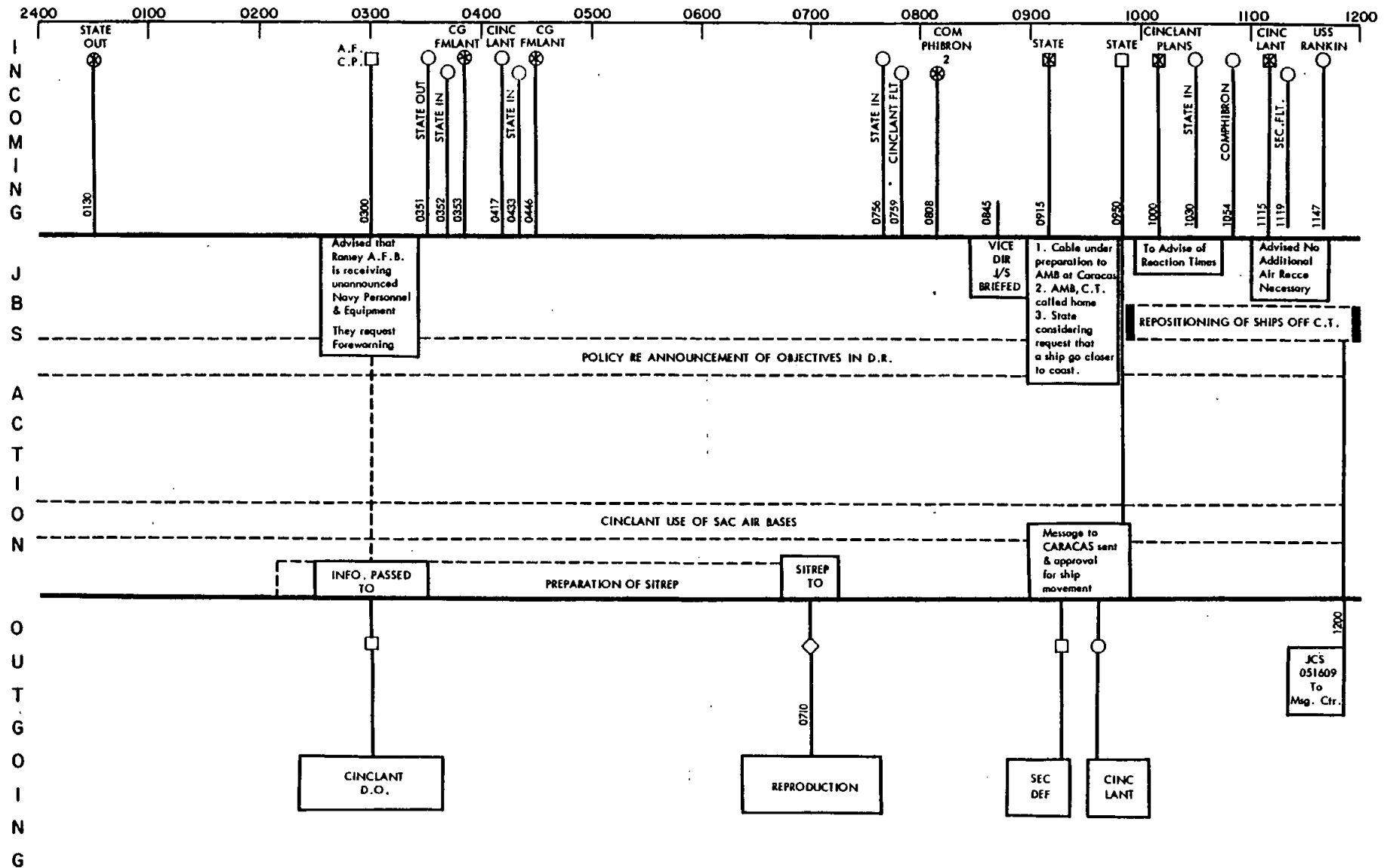

FIGURE 6A

8-11-62-12
~~TOP SECRET~~

~~TOP SECRET~~

JBS DAILY ACTIVITIES - 5 JUNE 1961

TIME (1200 TO 2400)

□ TELEPHONE
○ TELEGRAPH
◇ HAND CARRIED

○ PERSONAL CONVERSATION
--- JCS ACTION MESSAGE UNDER CONSIDERATION
..... RELATED ACTIVITIES

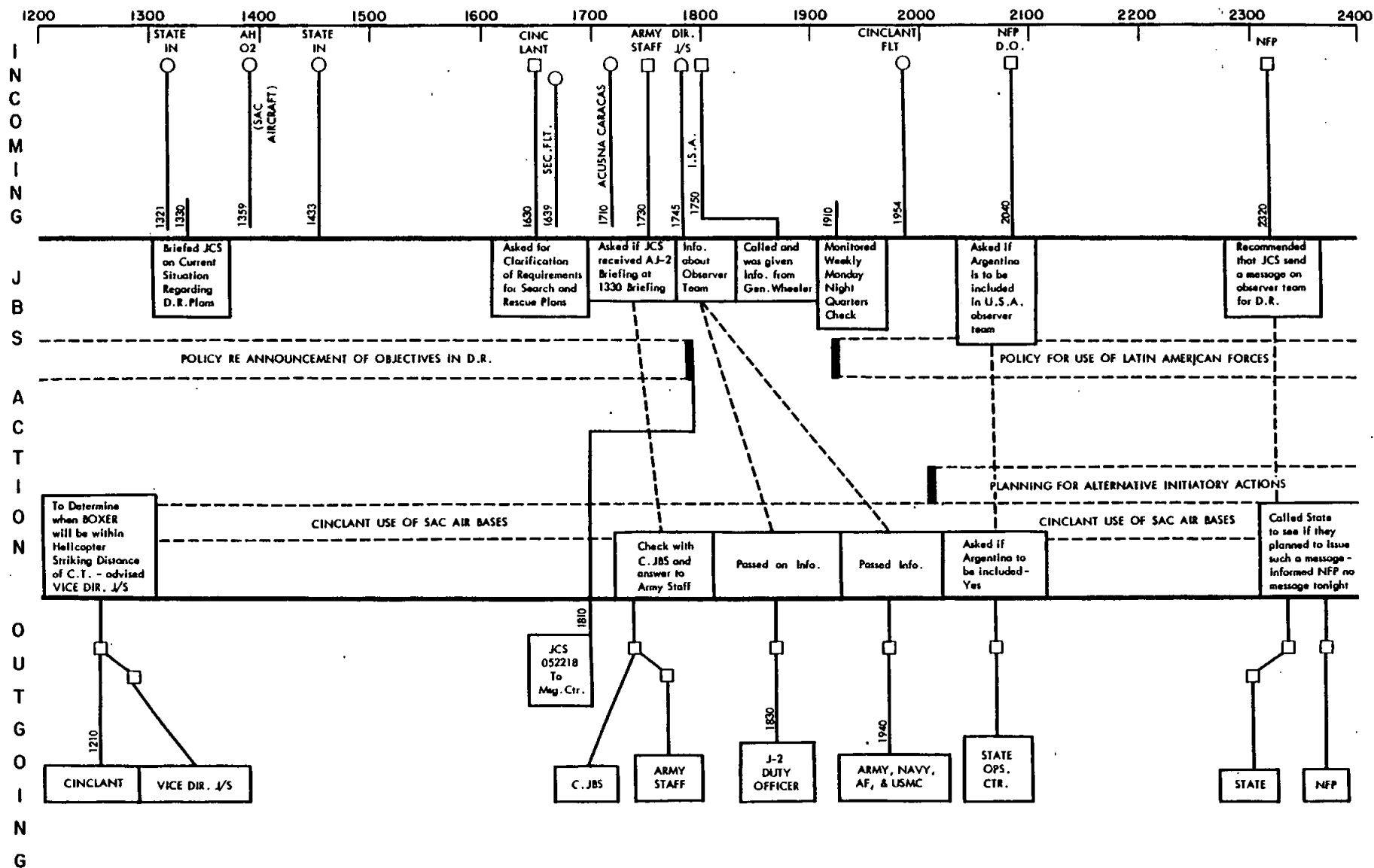

FIGURE 68

8-11-62-13

~~TOP SECRET~~

~~TOP SECRET~~

JBS DAILY ACTIVITIES - 6 JUNE 1961

TIME (2400 TO 1200)

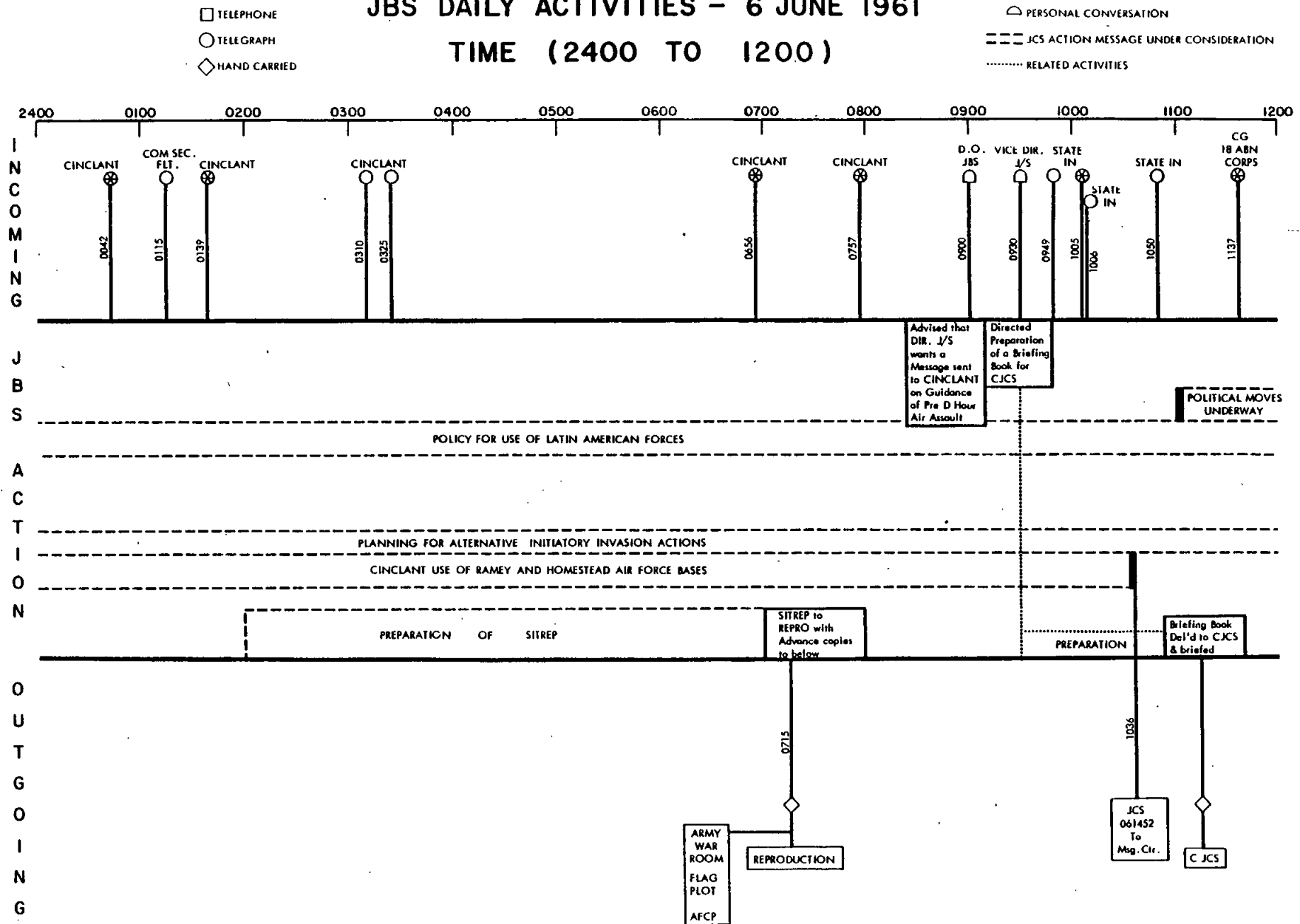

FIGURE 7A

TOP SECRET

8-11-62-14

TOP SECRET

JBS DAILY ACTIVITIES - 6 JUNE 1961 TIME (1200 TO 2400)

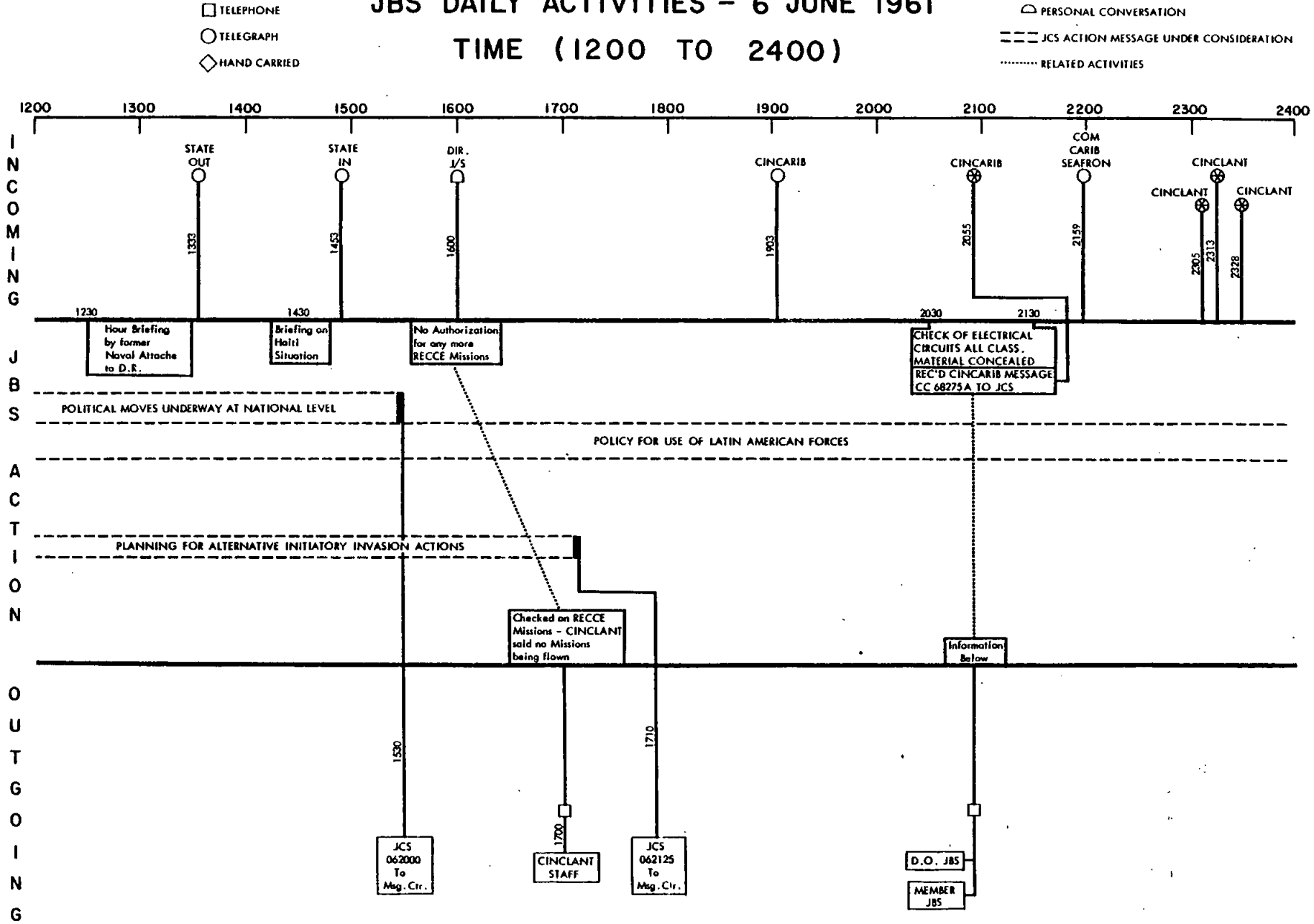

FIGURE 78

TOP SECRET
8-11-62-15

TOP SECRET

JBS DAILY ACTIVITIES - 7 JUNE 1961

TIME (2400 TO 1200)

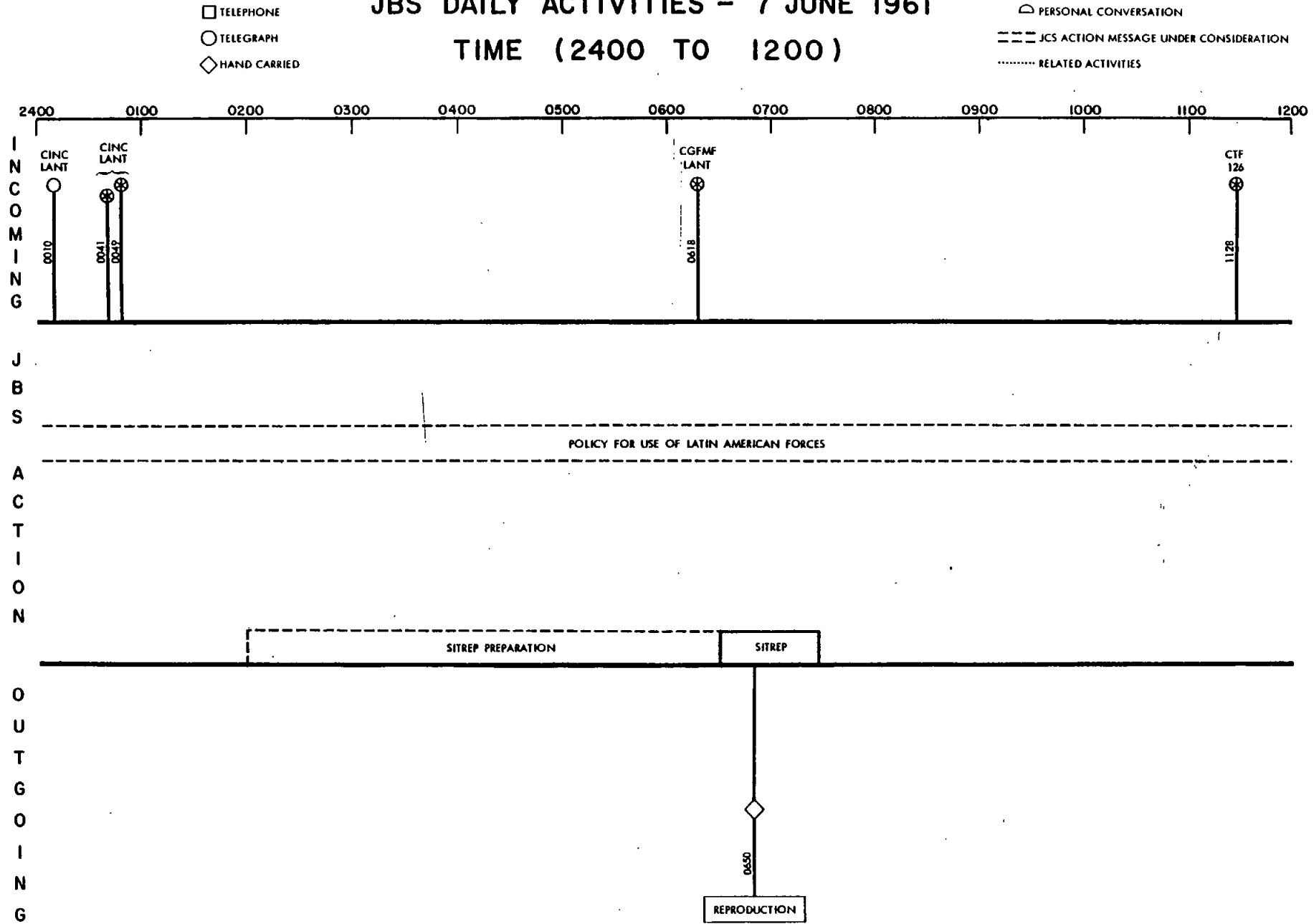

FIGURE 8A

JBS DAILY ACTIVITIES - 7 JUNE 1961

TIME (1200 TO 2400)

□ TELEPHONE
○ TELEGRAPH
◇ HAND CARRIED

△ PERSONAL CONVERSATION
- - - JCS ACTION MESSAGE UNDER CONSIDERATION
..... RELATED ACTIVITIES

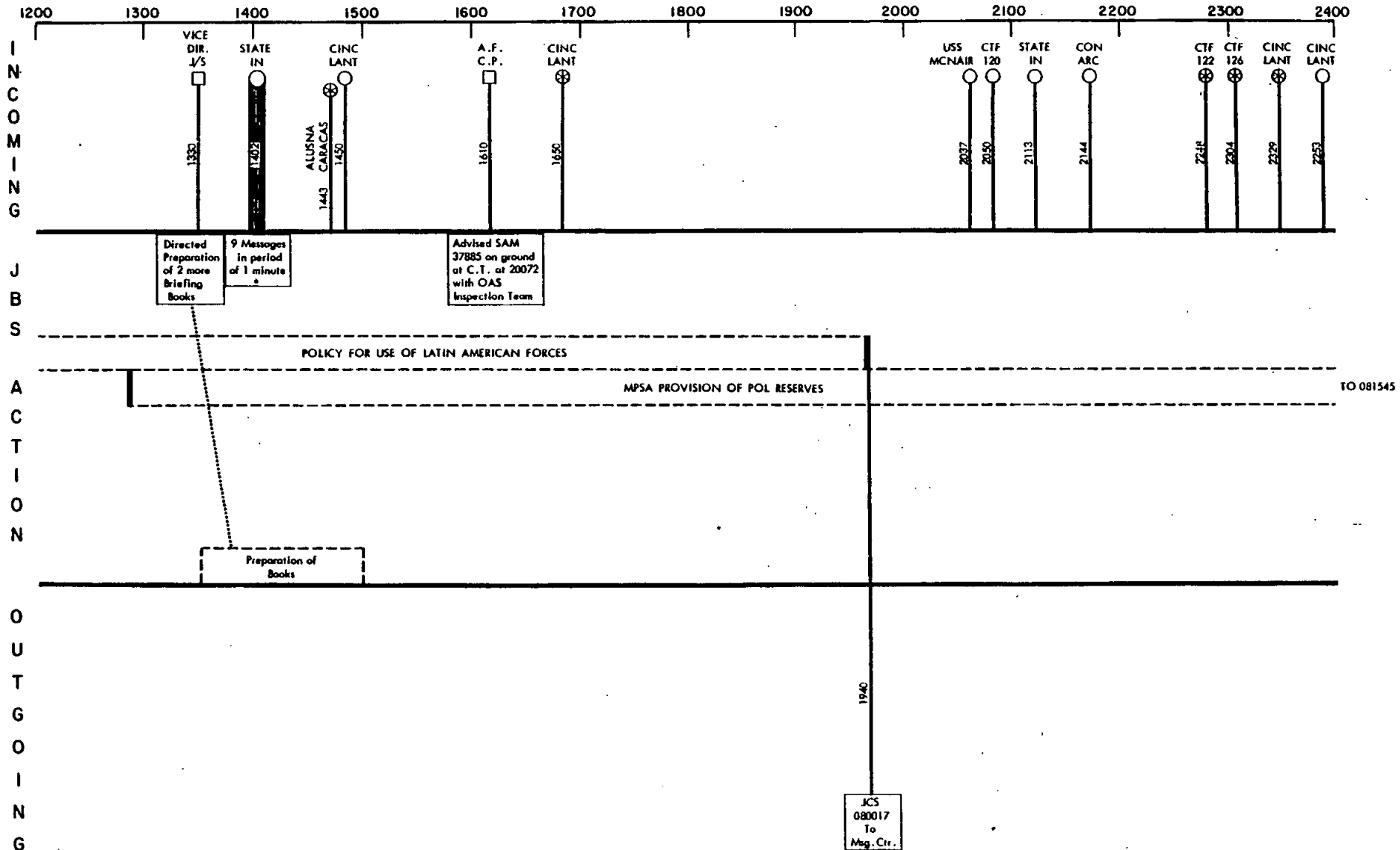

FIGURE 88

TOP SECRET
8-11-62-17

TOP SECRET

JBS DAILY ACTIVITIES - 8 JUNE 1961

TIME (2400 TO 1200)

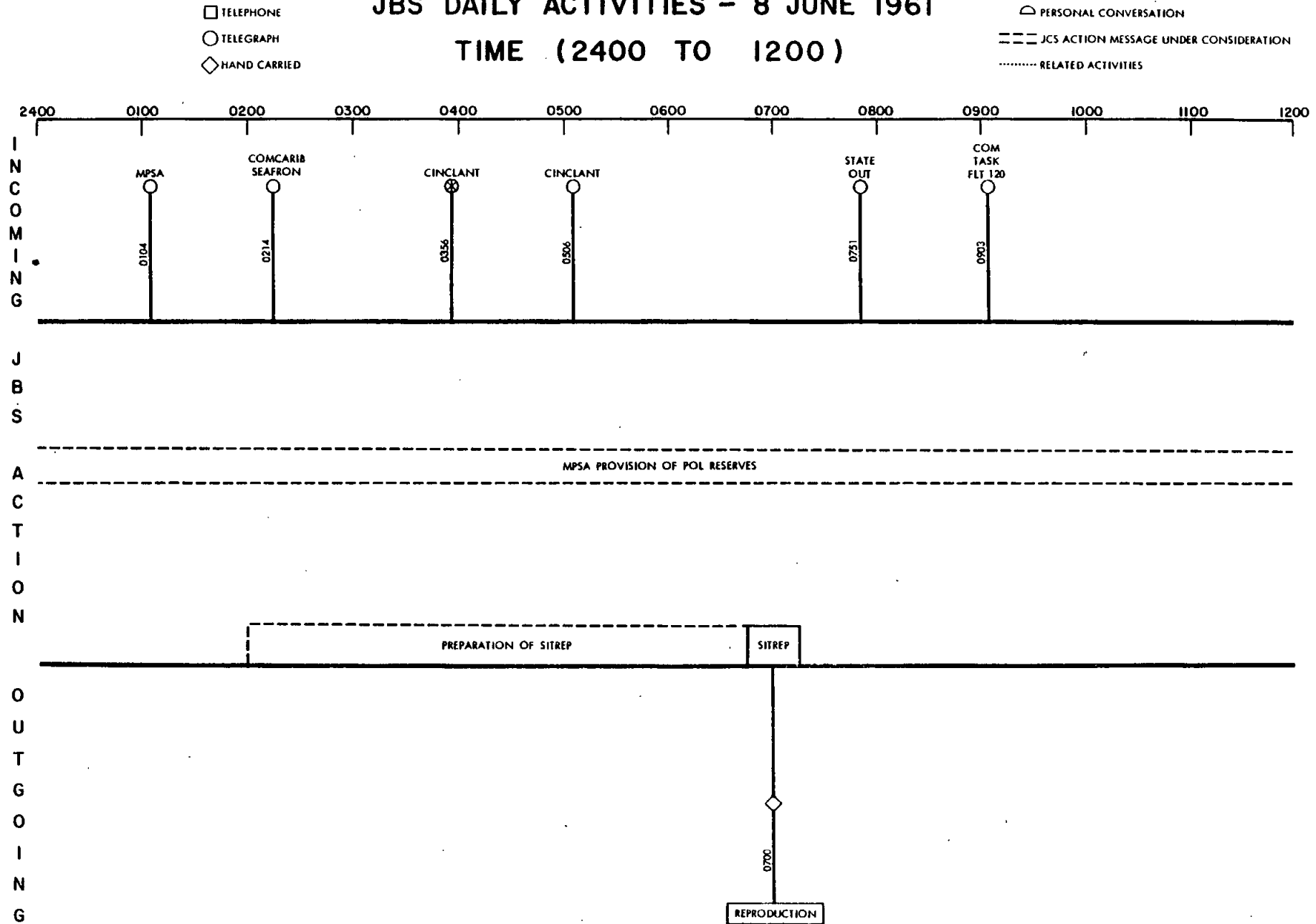

FIGURE 9A

TOP SECRET
8-11-62-18

TOP SECRET

JBS DAILY ACTIVITIES - 8 JUNE 1961

TIME (1200 TO 2400)

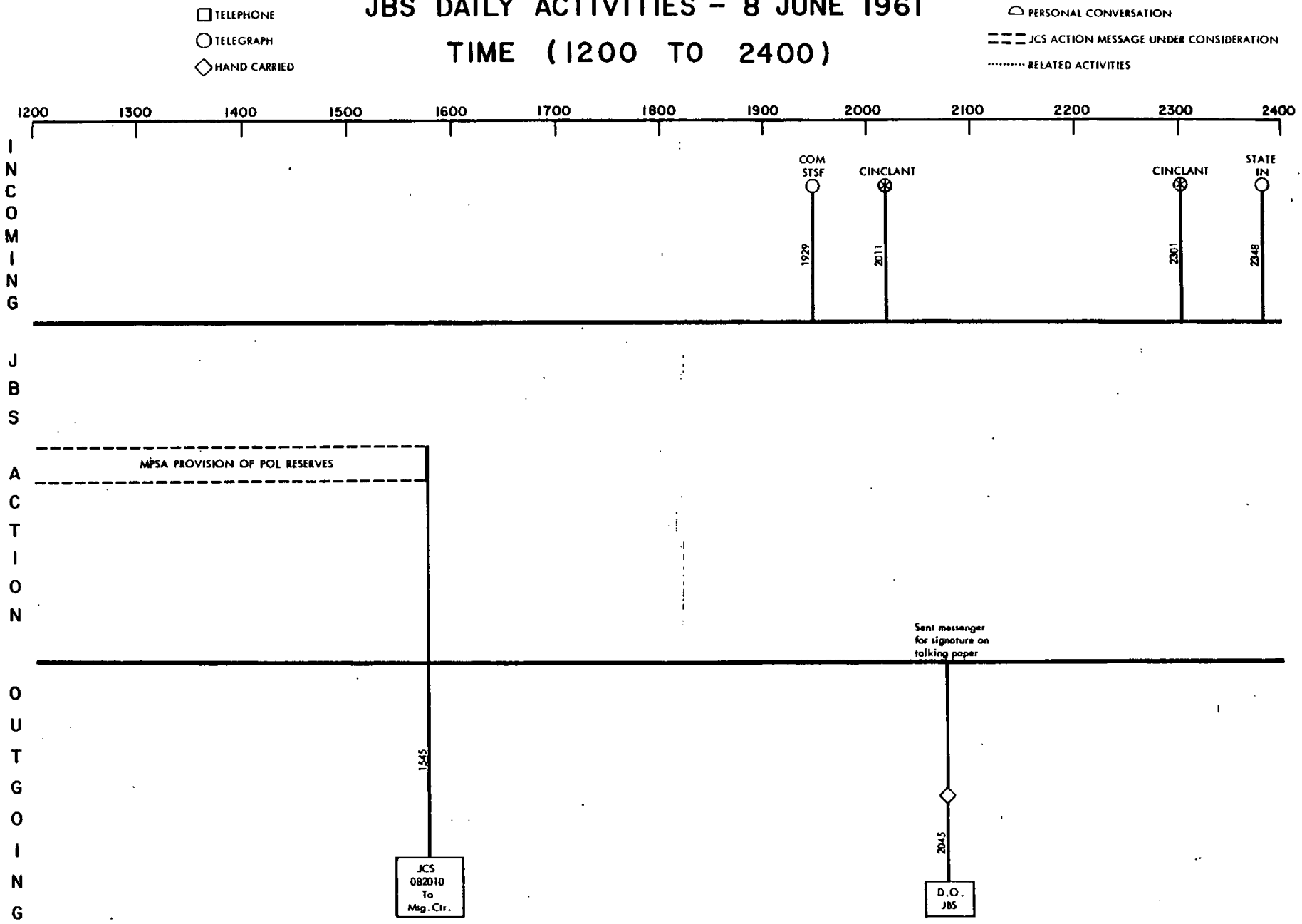

FIGURE 9B

8-11-62-19
TOP SECRET

TOP SECRET

JBS DAILY ACTIVITIES - 9 JUNE 1961

TIME (2400 TO 1200)

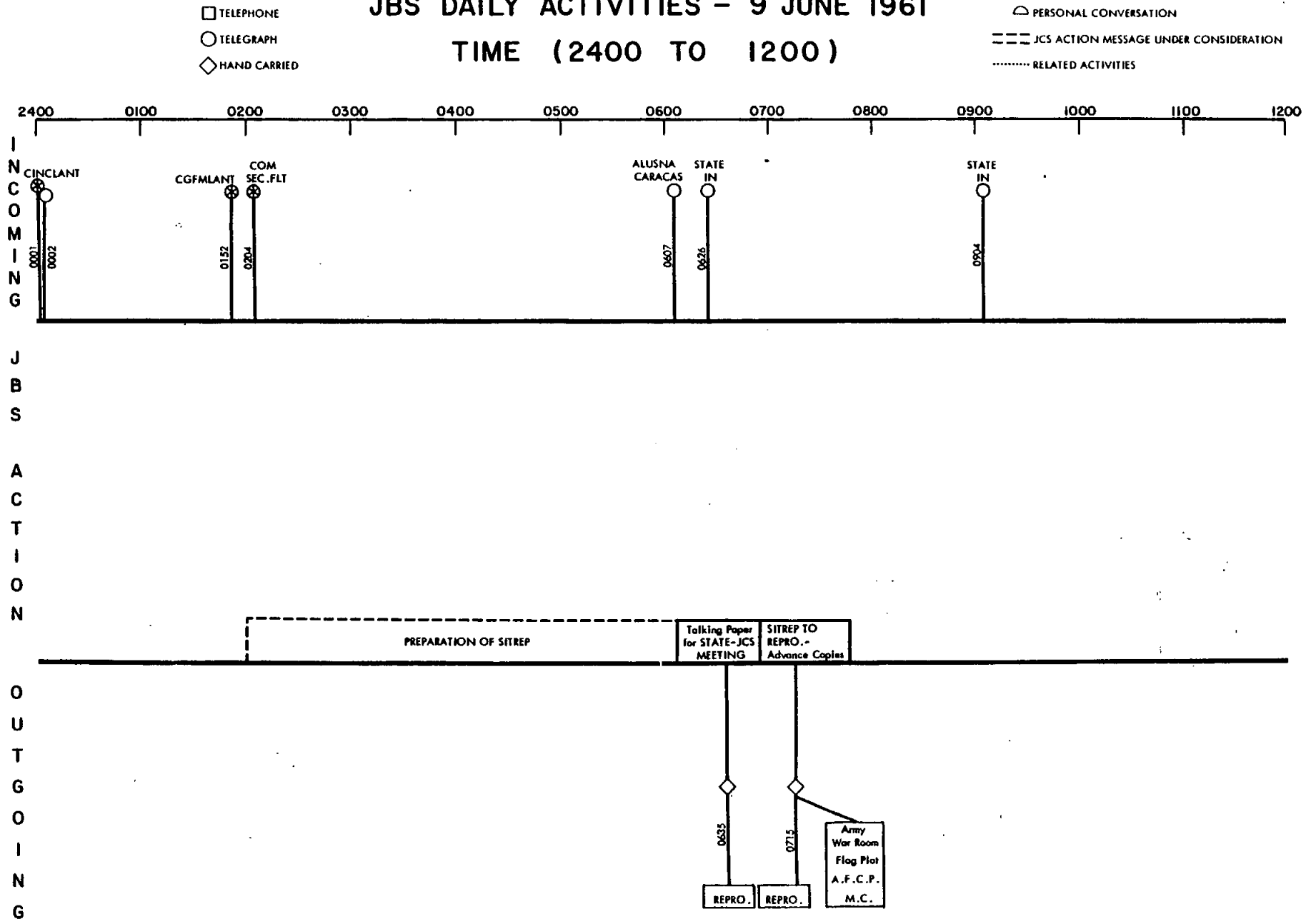

FIGURE 10A

8-11-62-20
~~TOP SECRET~~

~~TOP SECRET~~

JBS DAILY ACTIVITIES - 9 JUNE 1961

TIME (1200 TO 2400)

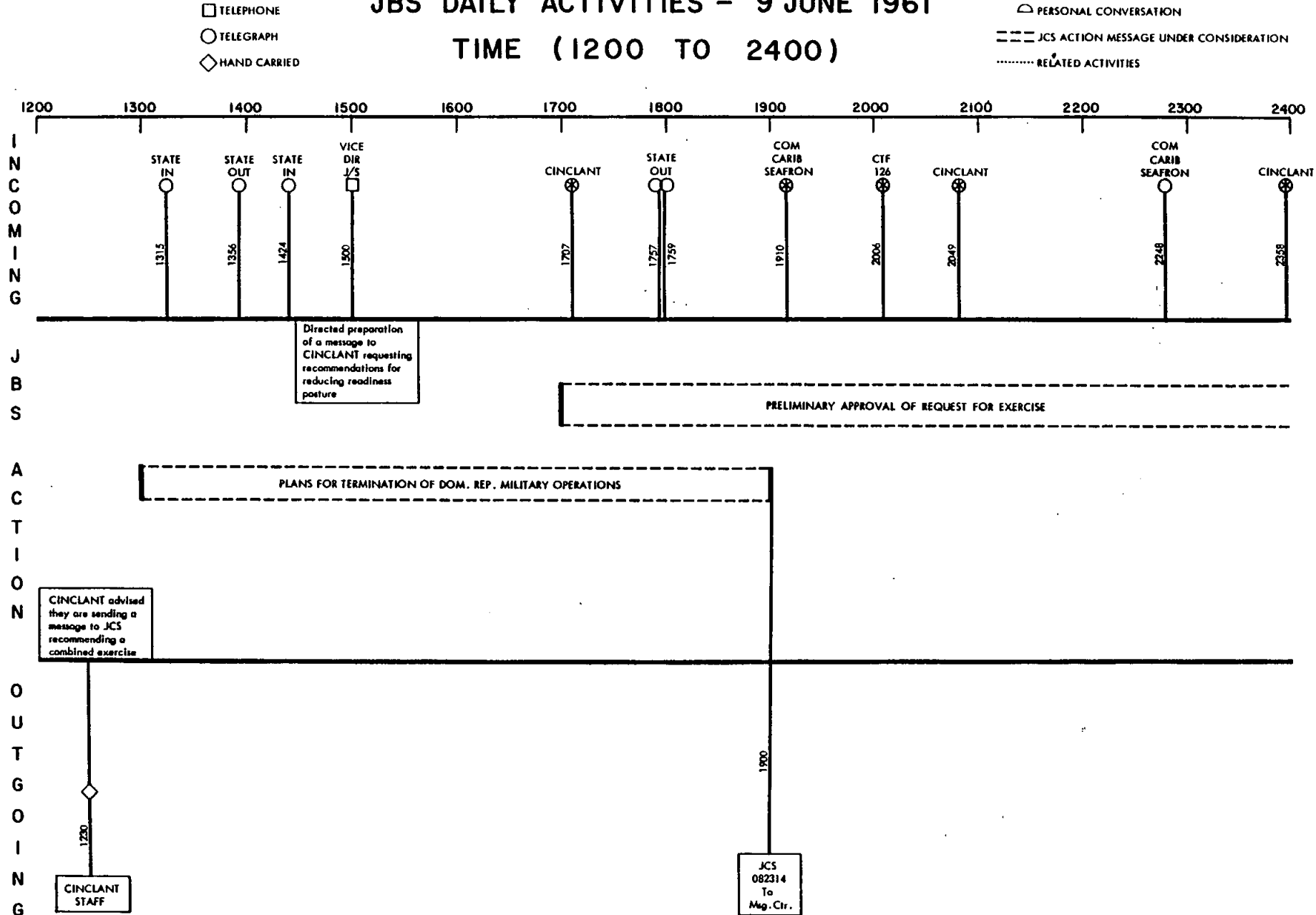

FIGURE 10B

8-11-62-21
~~TOP SECRET~~

~~TOP SECRET~~

JBS DAILY ACTIVITIES - 10 JUNE 1961

TIME (2400 TO 1200)

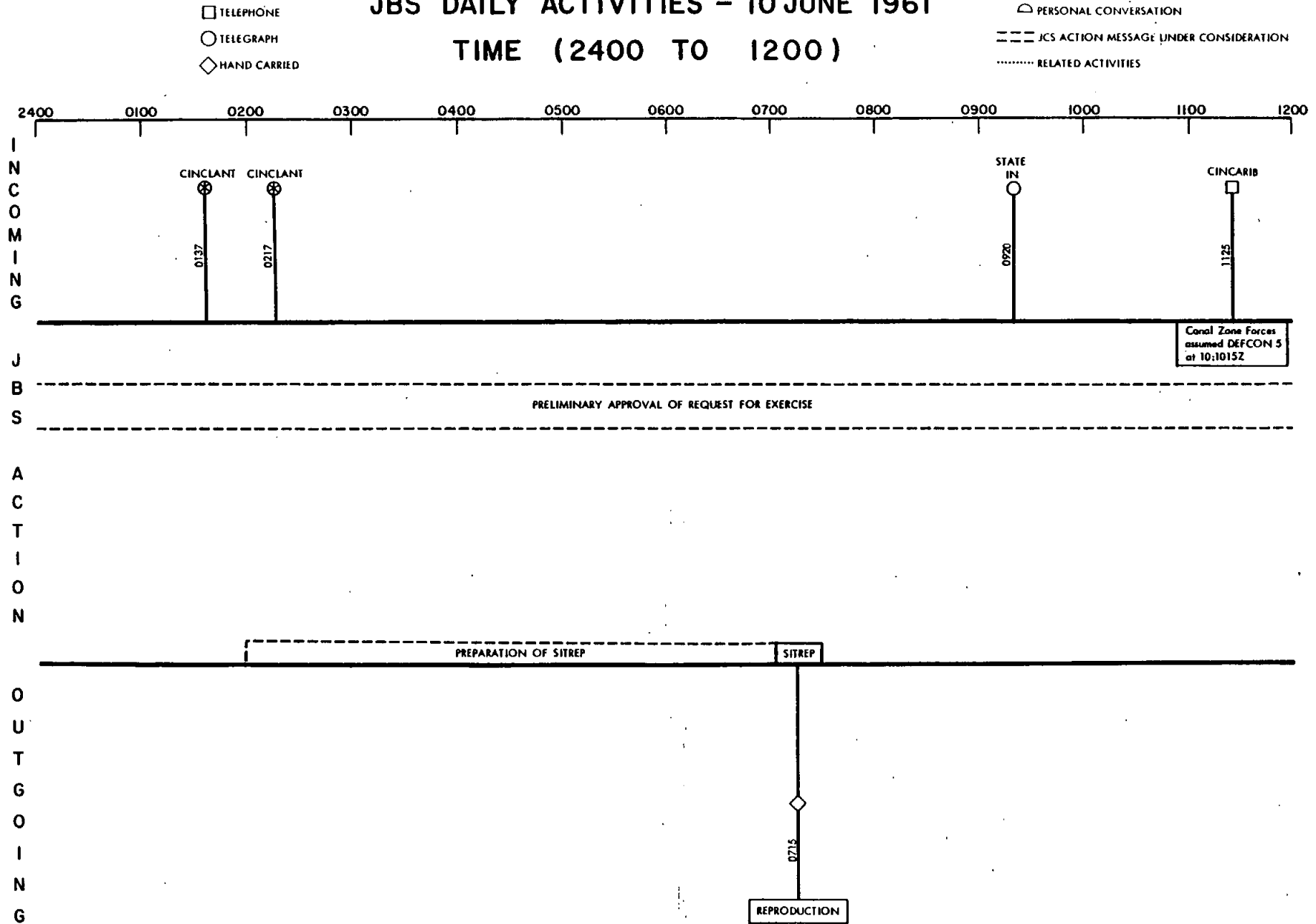

FIGURE 11A

TOP SECRET

8-11-62-22

TOP SECRET

JBS DAILY ACTIVITIES - 10 JUNE 1961 TIME (1200 TO 2400)

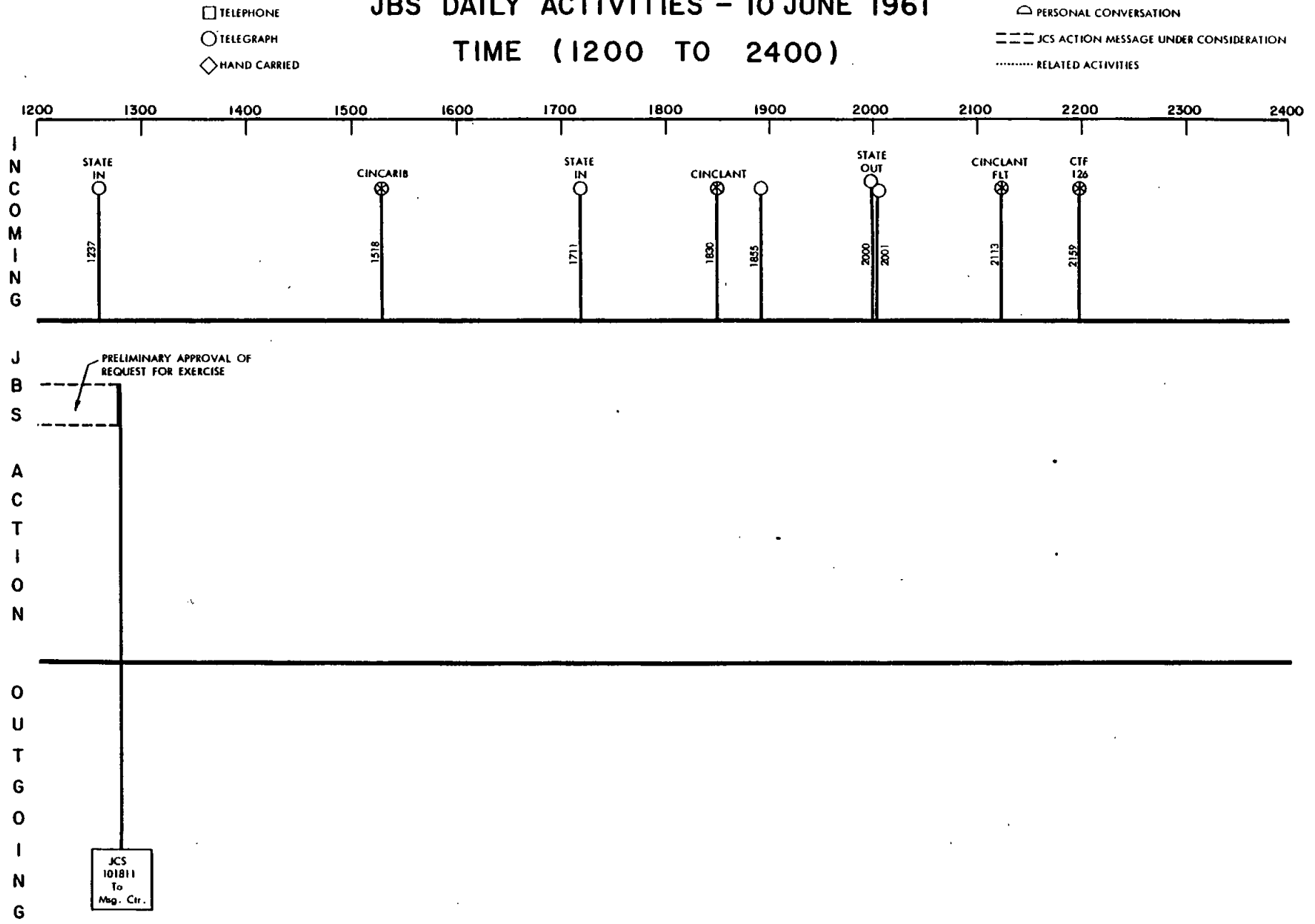

FIGURE 118

TOP SECRET
8-11-62-23

TOP SECRET

JBS DAILY ACTIVITIES - 11 JUNE 1961

TIME (2400 TO 1200)

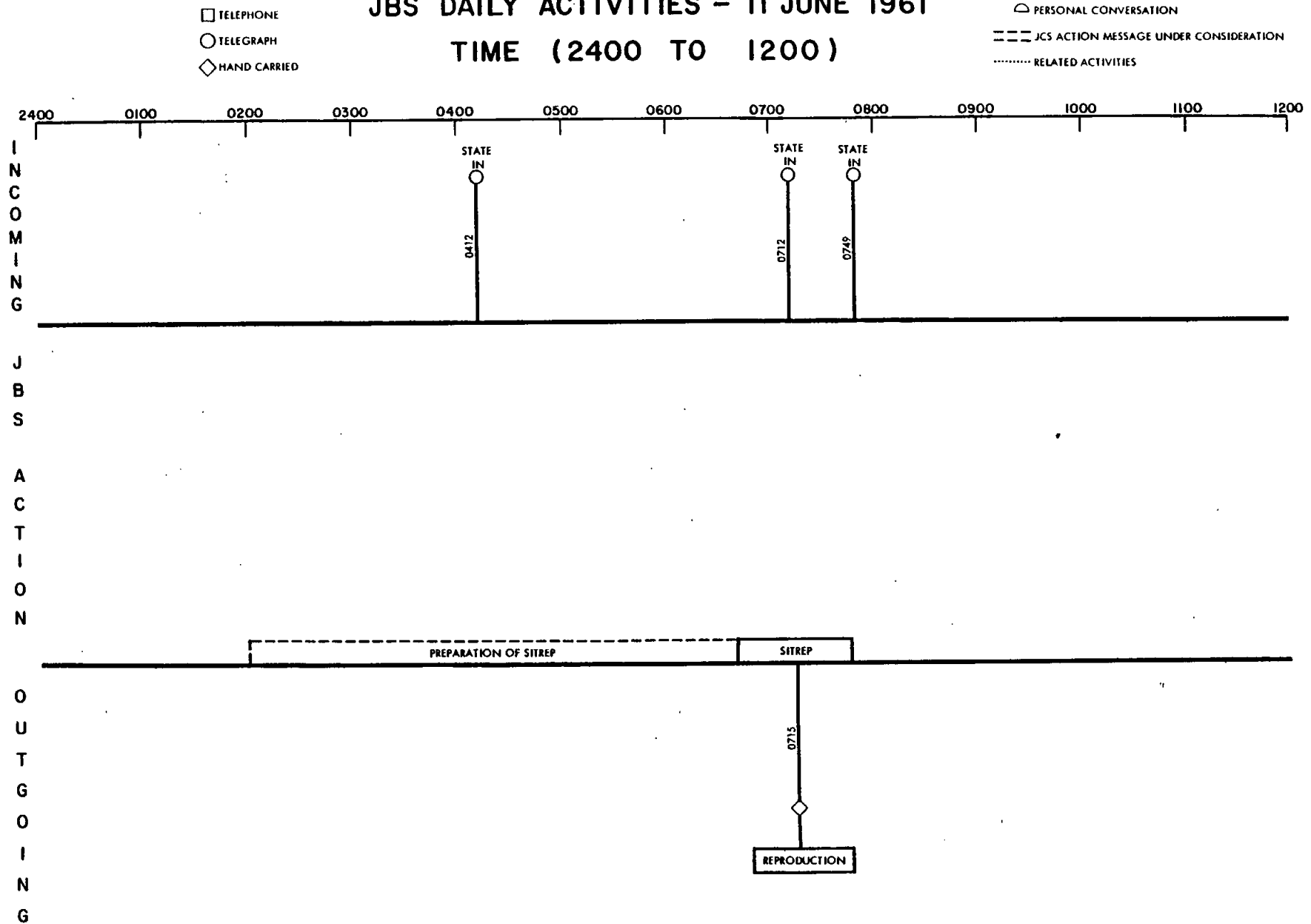

FIGURE 12A

TOP SECRET

8-11-62-24

TOP SECRET

JBS DAILY ACTIVITIES - 11 JUNE 1961

TIME (1200 TO 2400)

- TELEPHONE
- TELEGRAPH
- ◇ HAND CARRIED

- △ PERSONAL CONVERSATION
- ▬▬▬ JCS ACTION MESSAGE UNDER CONSIDERATION
- RELATED ACTIVITIES

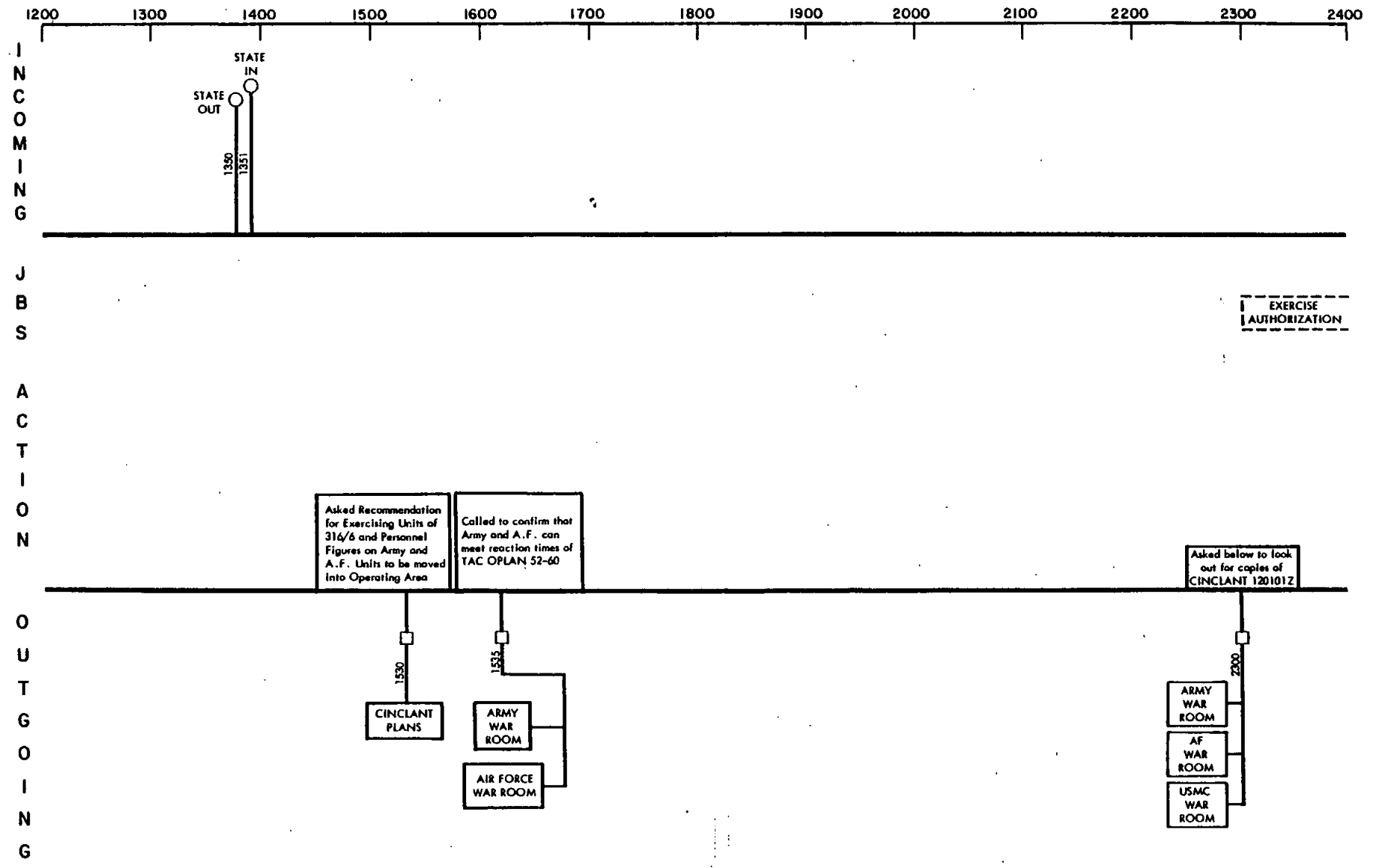

FIGURE 12B

8-11-62-25
~~TOP SECRET~~

~~TOP SECRET~~

JBS DAILY ACTIVITIES - 12 JUNE 1961

TIME (2400 TO 1200)

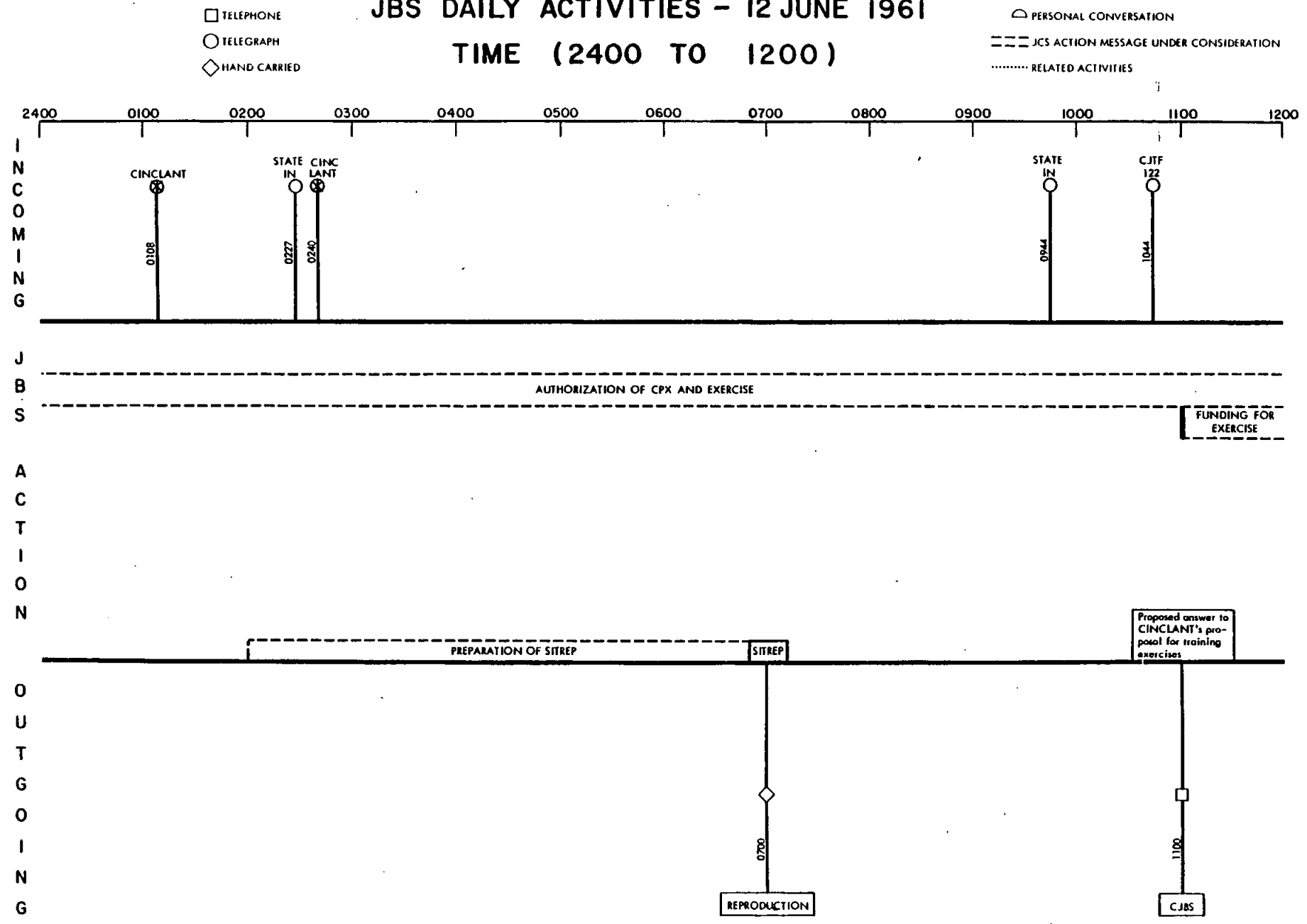

FIGURE 13A

8-11-62-26
~~TOP SECRET~~

~~TOP SECRET~~

JBS DAILY ACTIVITIES - 12 JUNE 1961

TIME (1200 TO 2400)

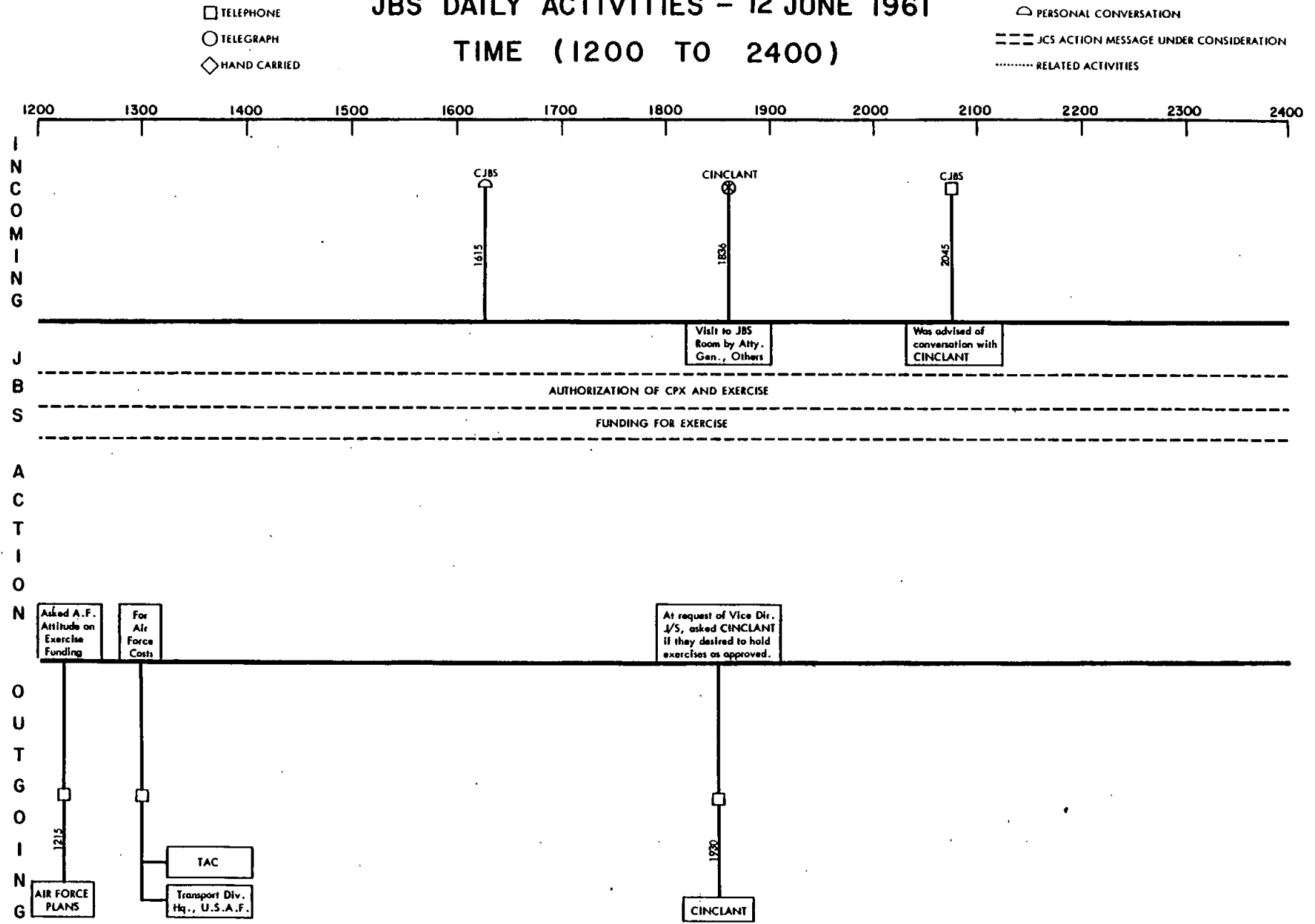

FIGURE 138

8-11-62-27
~~TOP SECRET~~

~~TOP SECRET~~

JBS DAILY ACTIVITIES - 13 JUNE 1961

TIME (2400 TO 1200)

- TELEPHONE
- TELEGRAPH
- ◇ HAND CARRIED

- △ PERSONAL CONVERSATION
- JCS ACTION MESSAGE UNDER CONSIDERATION
- RELATED ACTIVITIES

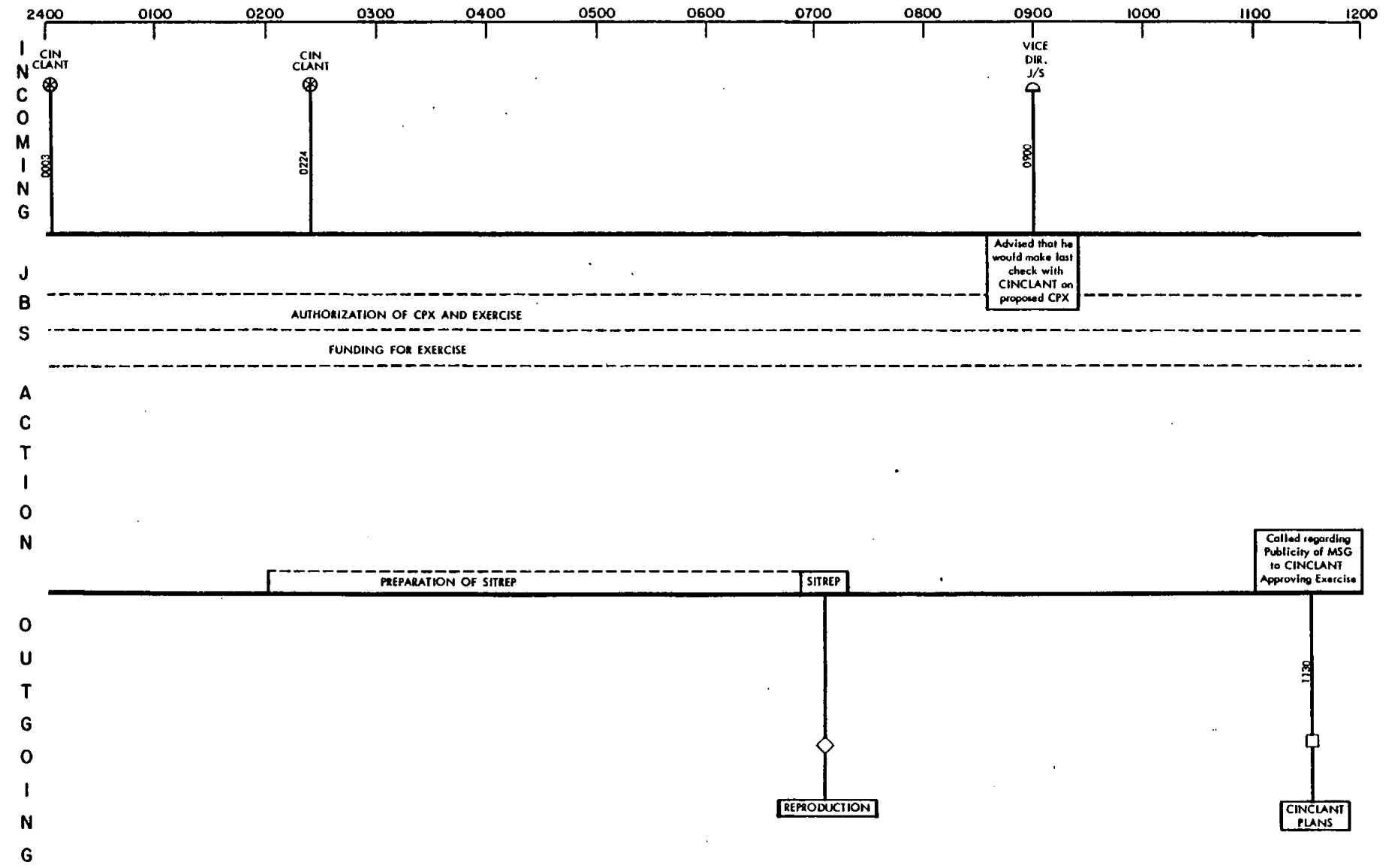

FIGURE 14A

TOP SECRET

8-11-62-28

TOP SECRET

JBS DAILY ACTIVITIES - 13 JUNE 1961 TIME (1200 TO 2400)

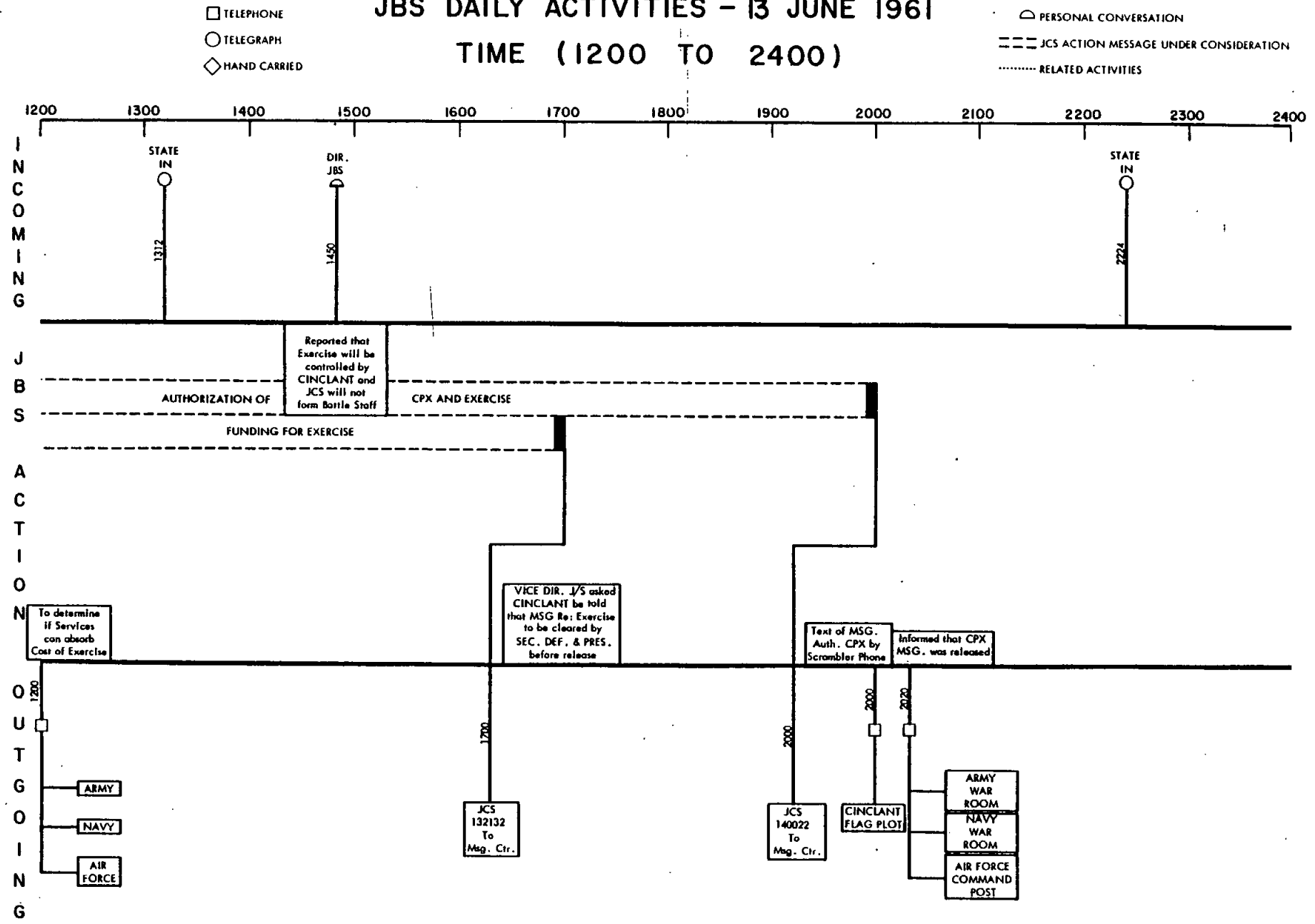

FIGURE 14B

TOP SECRET

8-11-62-29

TOP SECRET

JBS DAILY ACTIVITIES - 14 JUNE 1961 TIME (2400 TO 1200)

- TELEPHONE
- TELEGRAPH
- ◇ HAND CARRIED

- △ PERSONAL CONVERSATION
- ▬▬▬ JCS ACTION MESSAGE UNDER CONSIDERATION
- RELATED ACTIVITIES

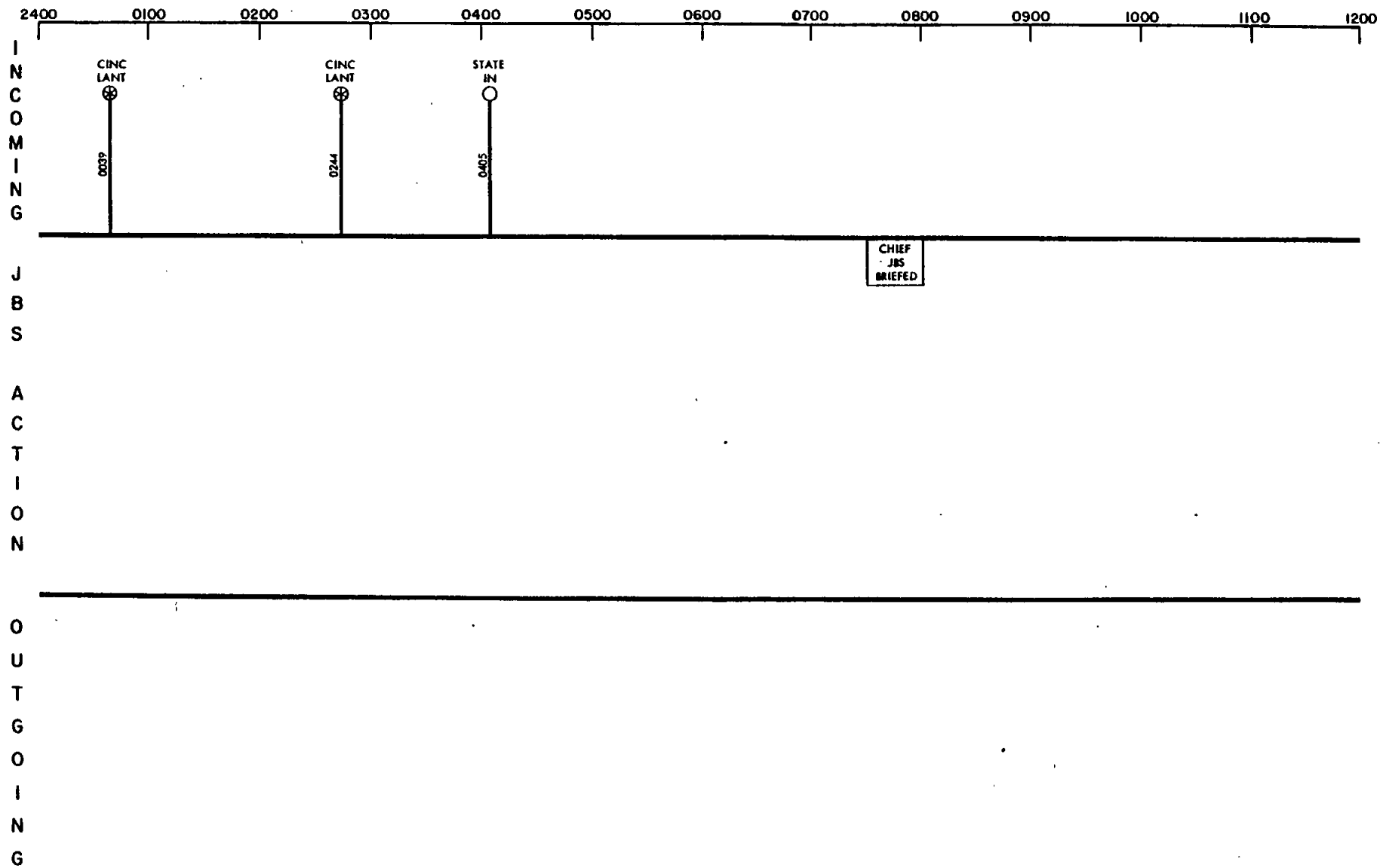

FIGURE 15A

8-11-62-30

~~TOP SECRET~~

~~TOP SECRET~~

JBS DAILY ACTIVITIES - 14 JUNE 1961 TIME (1200 TO 2400)

- TELEPHONE
- TELEGRAPH
- ◇ HAND CARRIED

- △ PERSONAL CONVERSATION
- JCS ACTION MESSAGE UNDER CONSIDERATION
- RELATED ACTIVITIES

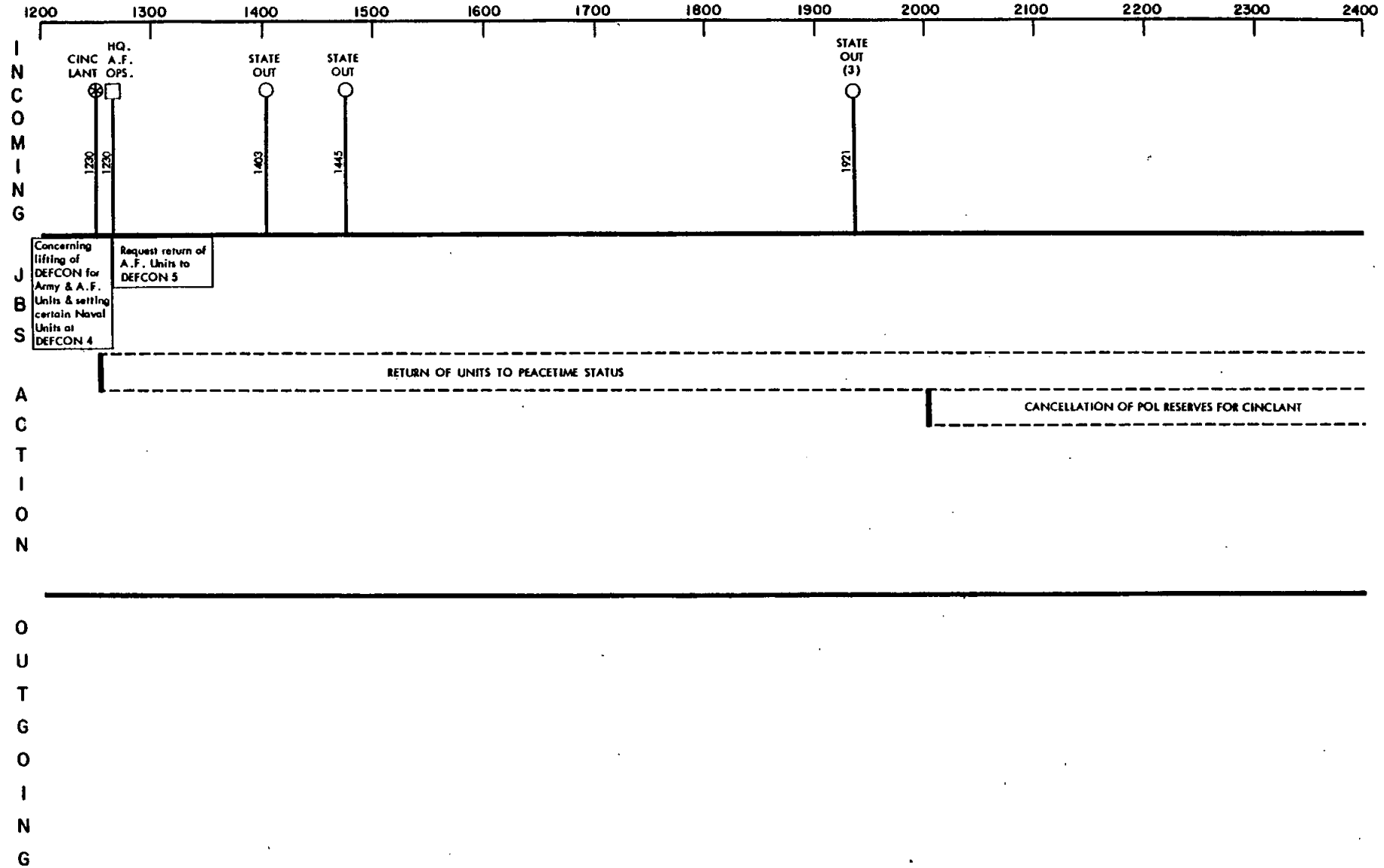

FIGURE 158

TOP SECRET

8-11-62-31

TOP SECRET

JBS DAILY ACTIVITIES - 15 JUNE 1961

TIME (2400 TO 1200)

- TELEPHONE
- TELEGRAPH
- ◇ HAND CARRIED

- △ PERSONAL CONVERSATION
- JCS ACTION MESSAGE UNDER CONSIDERATION
- RELATED ACTIVITIES

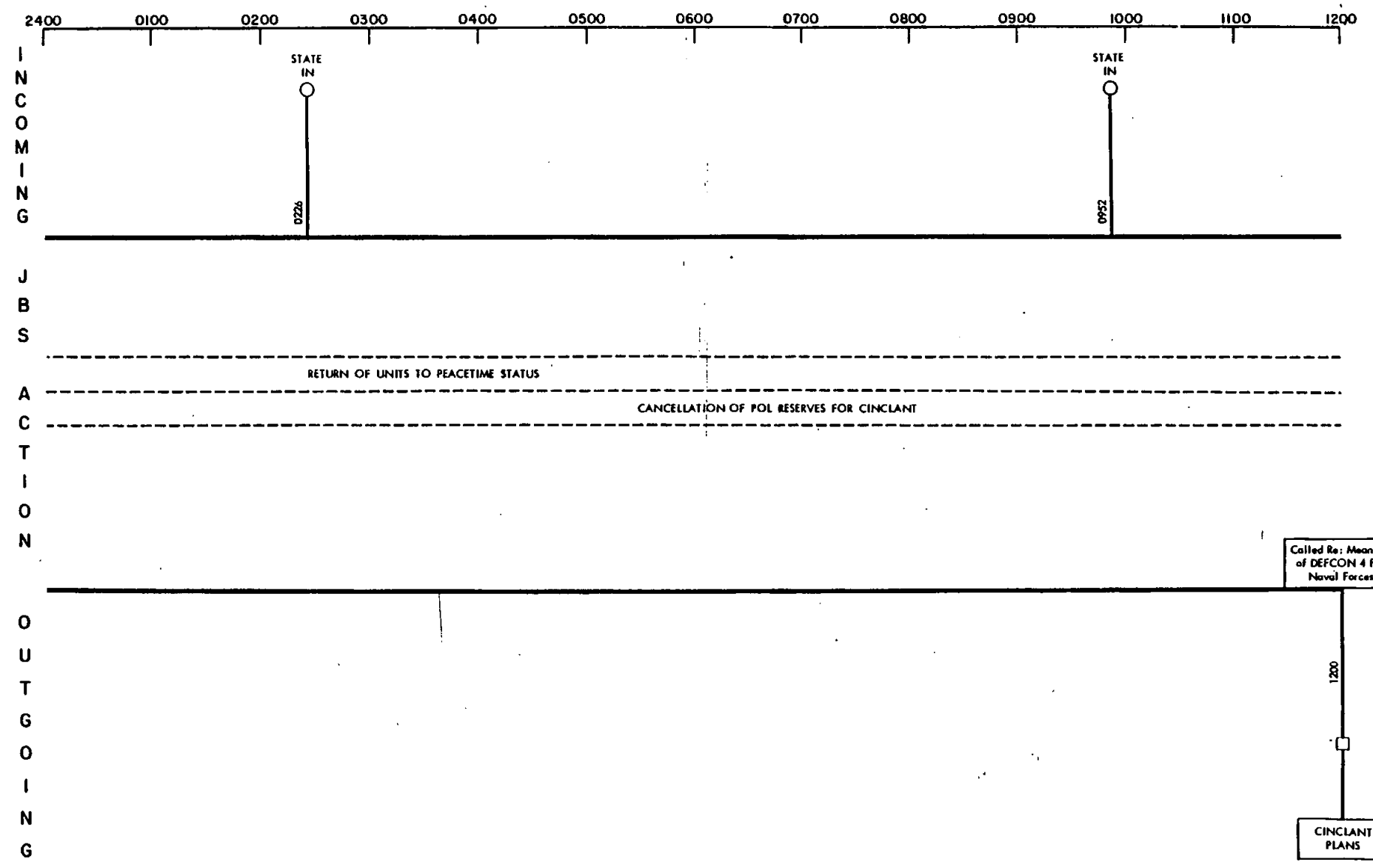

FIGURE 16A.

JBS DAILY ACTIVITIES - 15 JUNE 1961

TIME (1200 TO 2400)

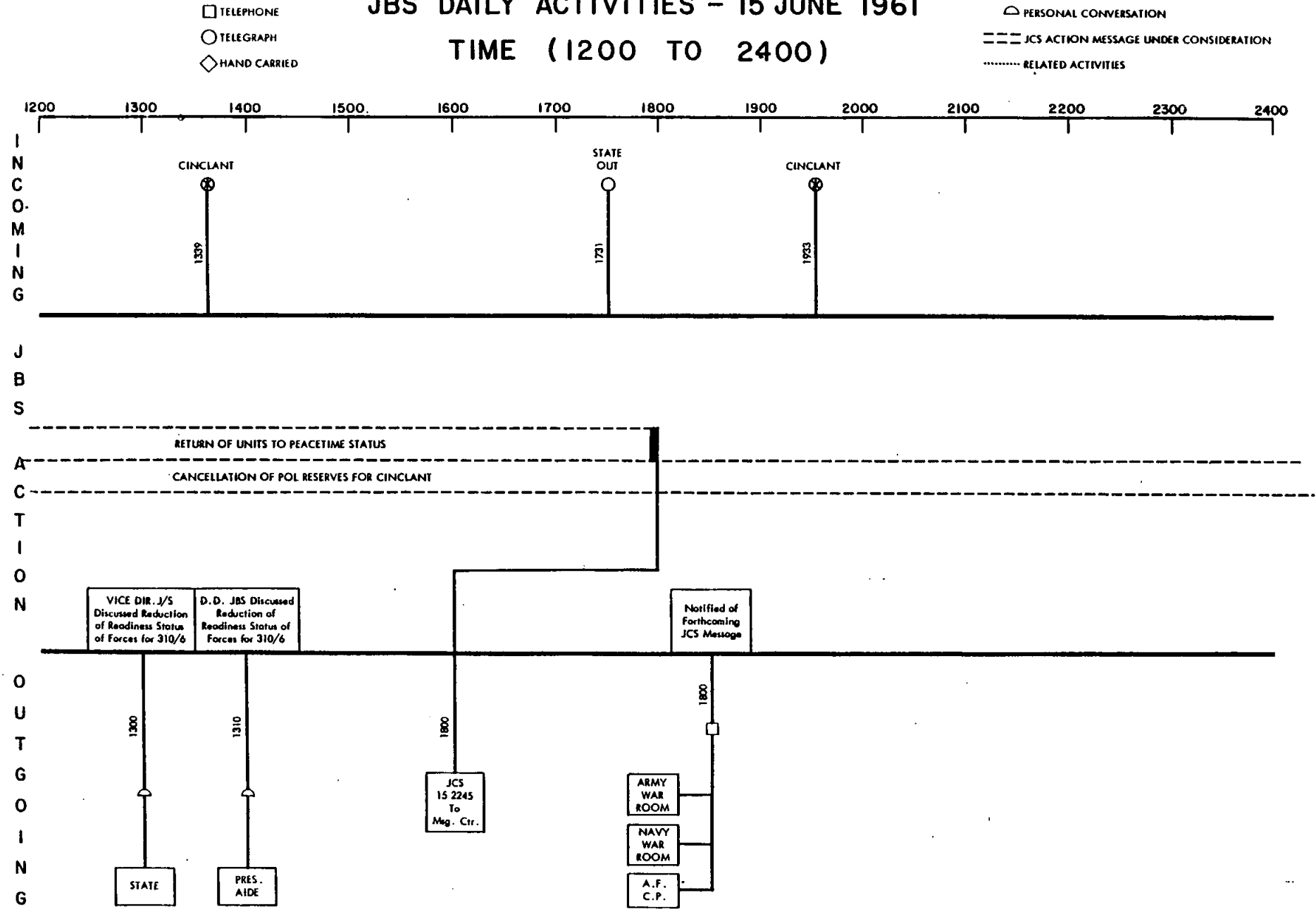

FIGURE 16B

TOP SECRET
8-11-62-33

TOP SECRET

JBS DAILY ACTIVITIES -16 JUNE 1961

TIME (2400 TO 1200)

- TELEPHONE
- TELEGRAPH
- ◇ HAND CARRIED

- △ PERSONAL CONVERSATION
- JCS ACTION MESSAGE UNDER CONSIDERATION
- RELATED ACTIVITIES

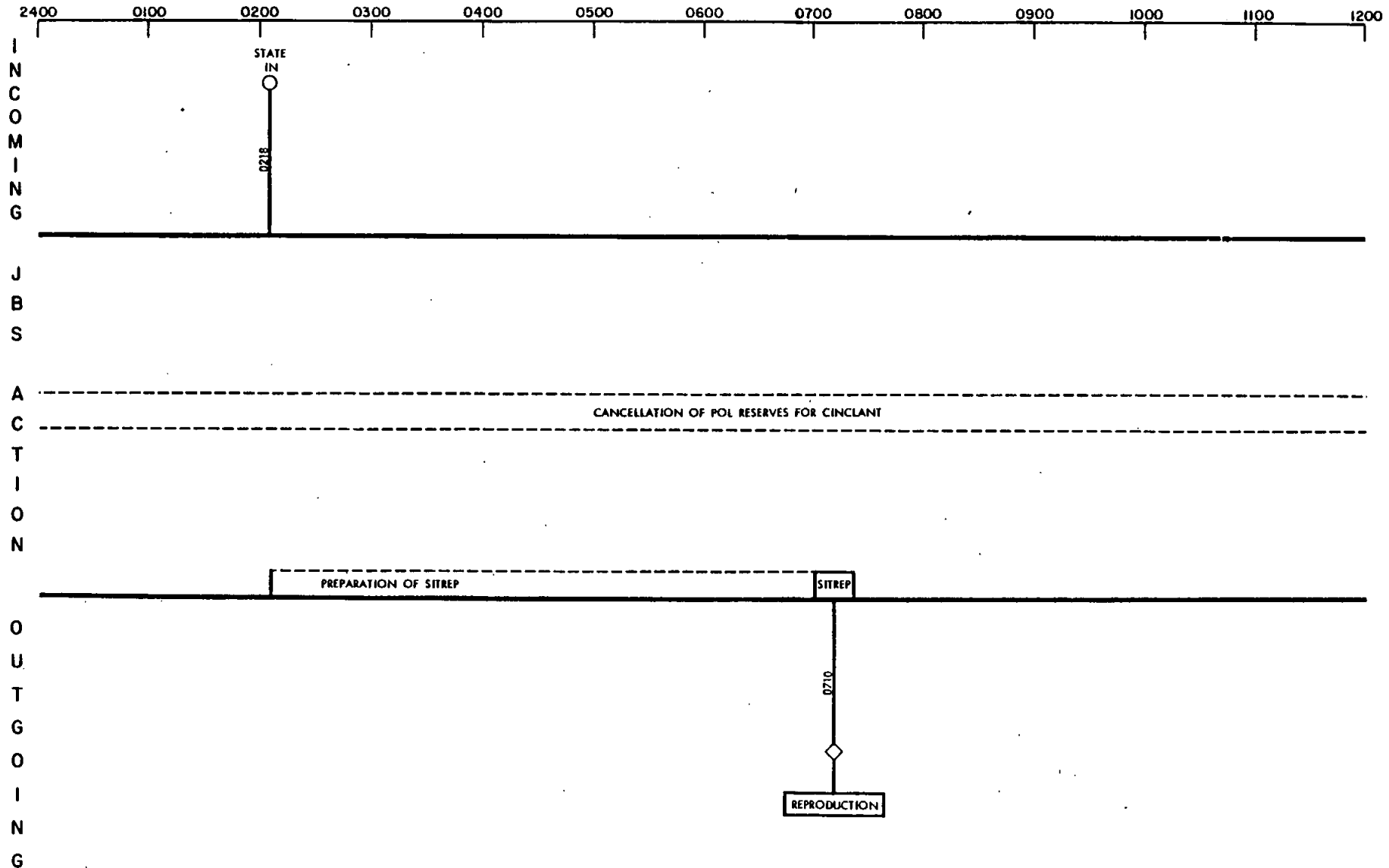

FIGURE 17A

8-11-62-34
~~TOP SECRET~~

~~TOP SECRET~~

JBS DAILY ACTIVITIES - 16 JUNE 1961

TIME (1200 TO 2400)

- TELEPHONE
- TELEGRAPH
- ◇ HAND CARRIED

- △ PERSONAL CONVERSATION
- ▨ JCS ACTION MESSAGE UNDER CONSIDERATION
- RELATED ACTIVITIES

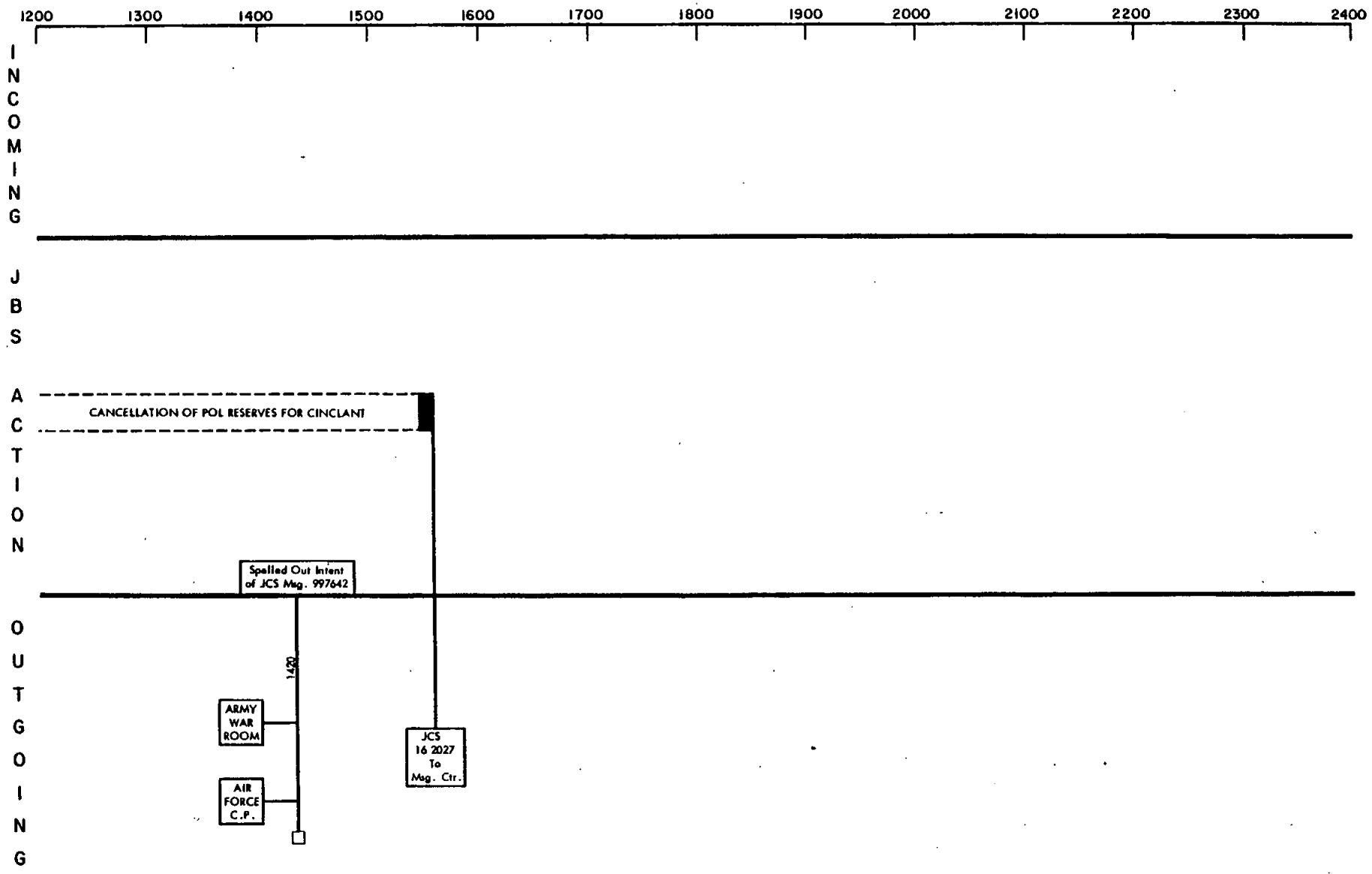

FIGURE 178

TOP SECRET

8-11-62-35

TOP SECRET

JBS DAILY ACTIVITIES - 17 JUNE 1961

TIME (2400 TO 1200)

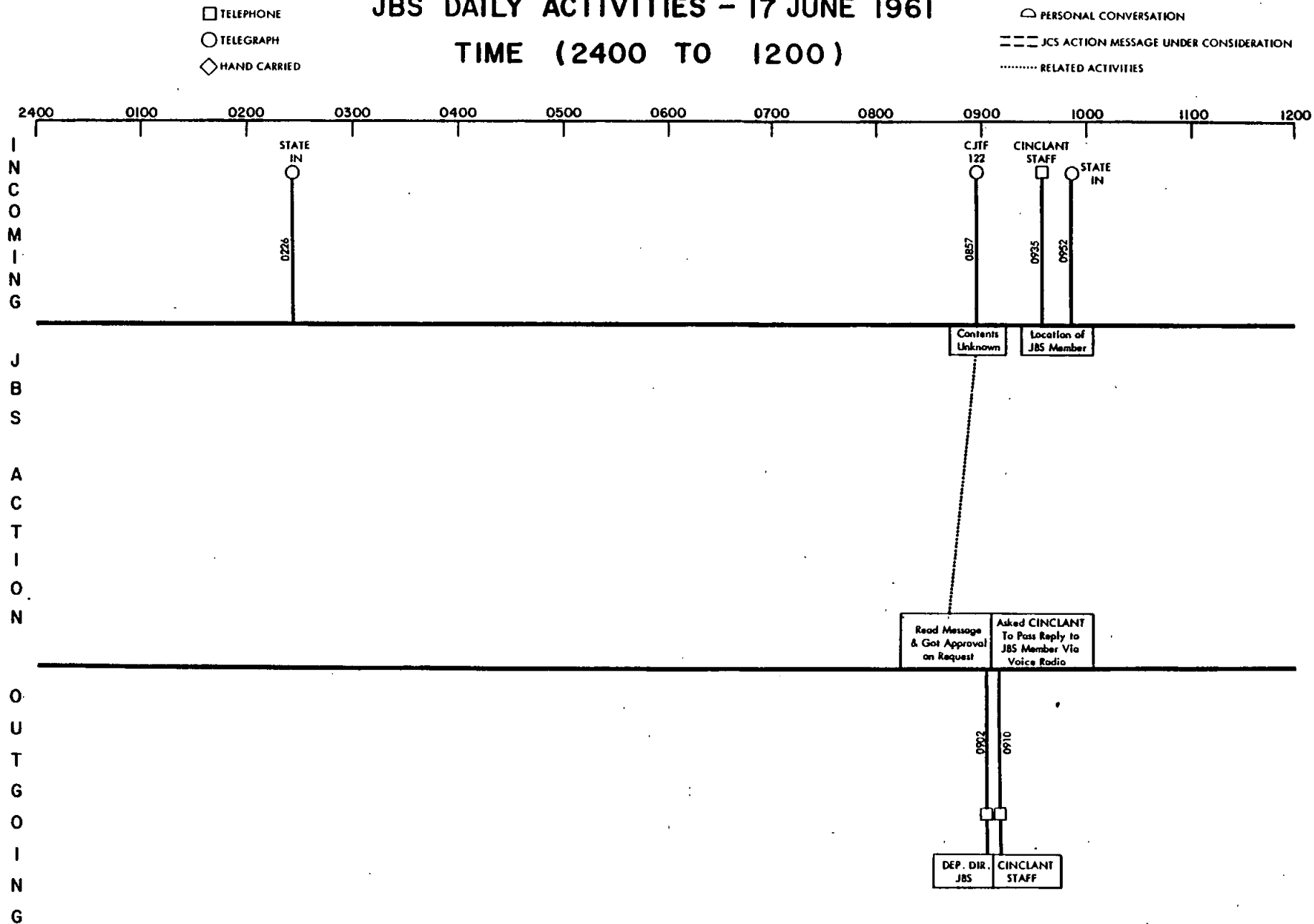

FIGURE 18A

8-11-62-36
~~TOP SECRET~~

~~TOP SECRET~~

JBS DAILY ACTIVITIES - 17 JUNE 1961 TIME (1200 TO 2400)

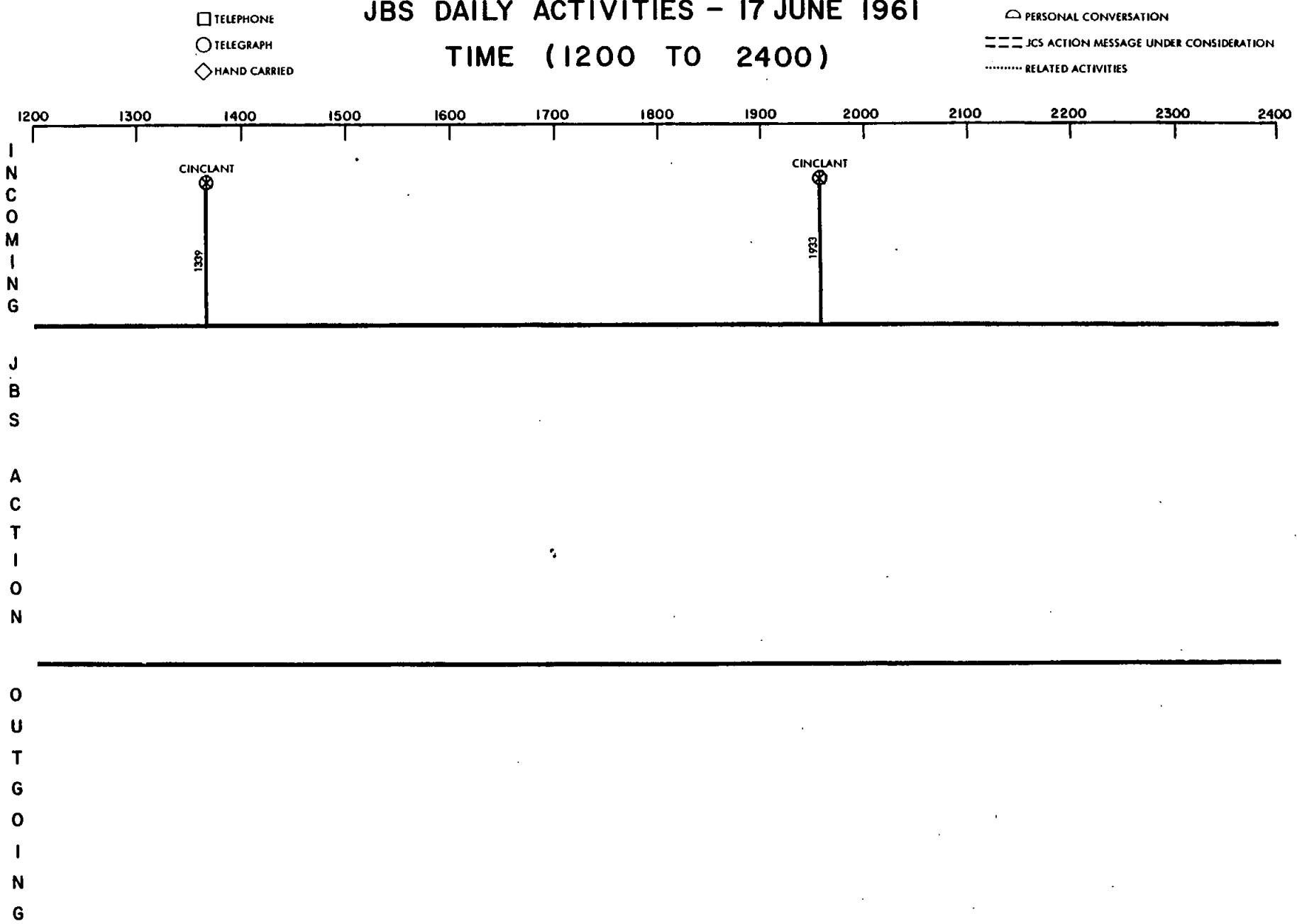

FIGURE 188

b. Essence of text of message (except telegraph where no action was required) and, where applicable, what actions followed in the JBS as result of message.

c. Method of information flow out of the JBS: including time where applicable, method of communication, nature of message, and recipient of message.

14. In order to portray this amount of information with some degree of clarity it was necessary to utilize symbols of several types. The following is a listing of the symbols used with explanation of what they represent.

- - telegraph
- - telephone
- ◇ - hand-carried
- ◐ - personal conversation.

15. Also indicated symbolically are those messages which are used in the preparation of daily situation reports (SITREPS). These are indicated by an asterisk (*) in the center of the communication channel symbol. The time received in the JBS is the time as recorded either in the JBS Log or on the Daily Staff Journal. If the time received is not found in either of these sources then the time the message is received in Washington is used. The text of the message received is indicated on the chart for all telephone, hand-carried, or personal conversation messages. For those messages received by telegraph the text is recorded on the chart only if the message resulted in some action on the part of the JBS.

16. The horizontal line at the top of each chart is the time reference (0000-2400) in local time (EDT) for each daily period. The charts are most easily read from top to bottom. The first entry below the time reference line will be the originating

source of a message. Below that will be found the symbol indicating the communication channel utilized. The symbol is followed by a vertical line. At the base of the line the time the message was received by JBS is indicated.

17. The center of the chart bounded by 2 horizontal lines represents the JBS. Within this section are indicated (within the constraints of the data available) the functions of the JBS. Each of the incoming messages required some activity on the part of one or more members of the JBS. Each message had to be reviewed and a decision was required for each one, i.e., to file it, use in SITREP, pass on to higher authority, to collate with other information, etc. Represented in time blocks (within dotted lines) within this section are actions in preparation or under consideration which resulted in JCS-Out messages. The precise functions being performed are not indicated but the blocks represent the time from receipt of requirements information in the JBS until the time the J/S action was completed. It must be remembered that while one or more of the JBS members are involved in this activity the normal message inflow and subsequent activity are concurrently taking place with its necessary involvement of additional members of the JBS.

18. The area below the JBS horizontal band contains outgoing messages from the JBS. Again we have the communication channel symbol followed by the vertical communication substance line. Beneath this line will be found the recipient of the outgoing message.

19. Information flow and each of the functions portrayed on the charts will be examined in some detail in subsequent sections of this paper. The purpose of these figures is to graphically illustrate the JBS as the focal point of the crisis activity.

On 31 May, there was no Joint Battle Staff per se in action. The day is included, however, for purposes of continuity and to indicate initial actions by the Emergency Actions Branch and because, during the day, this group was supplemented by the personnel who on the following day were designated as the Dominican Republic Joint Battle Staff.

20. Table II summarizes the daily activities of the JBS as the focal point for Joint Staff involvement in the Dominican Republic crisis. The number of telegraphic messages and number of informal communications received each day are recorded as indicative of the incoming volume of work. The number of major actions under consideration illustrates the continuing workload of members of the JBS. The number of outgoing contacts effected indicates the coordination and action products completed by the JBS members. The last column attempts to indicate the shape of the June 1961 DR crisis activity, totaling the other columns for each day.

21. This table largely supports the conclusions drawn below which were developed from the daily charts. There were approximately 80 additional messages received which are found in the JBS files, but for which there was no record as to even the date of receipt. The "Major Activities Under Consideration" are the actions taken by the JBS in development of JCS outgoing messages. Since some of them continue over several days, they are not additive.

22. It can be seen that the first seven days (through 6 June) were periods of high activity. The peak of activity occurred on 2 and 3 June. In addition to the heavy message traffic both in and out of the JBS, 17 percent of all JCS action messages (for the entire crisis situation) were sent out on 2 June. On

~~TOP SECRET~~

~~TOP SECRET~~

TABLE II

SUMMARY OF RECORDED JBS DAILY ACTIVITIES^{a/}

Date (1961)	Number Telegraphic Messages Received	Number Informal Communications Received	Number Major Activities under Consideration	Number Outgoing Contacts Effected	"Shape of the Crisis" Total Activity Level
31 May	10	3	4	5	22
1 June	23	7	4	10	44
2 June	16	6	7	21	50
3 June	34	6	4	8	52
4 June	23	15	4	7	49
5 June	20	10	4	15	49
6 June	20	3	4	9	36
7 June	25	2	2	2	31
8 June	10	0	1	3	14
9 June	18	1	2	5	26
10 June	16	1	1	1	19
11 June	7	0	0	7	14
12 June	6	3	2	11	22
13 June	8	4	2	9	23
14 June	10	2	2	1	15
15 June	8	2	2	6	18
16 June	1	0	1	3	5
17 June	<u>5</u>	<u>1</u>	<u>0</u>	<u>2</u>	<u>8</u>
TOTAL	260 ^{b/}	66	Not Additive	133	Not Additive

^{a/} Recorded individually in Appendix "C."

^{b/} Not including 80 messages on file for which records do not indicate time received by JBS.

~~TOP SECRET~~

~~TOP SECRET~~

52

3 and 4 June, although the rate of messages into the JBS was quite intense, there were fewer outgoing messages. Also there were fewer JCS messages under consideration and being sent for these two days than during the single day of June 2. It should be noted that 3 and 4 June were Saturday and Sunday.

23. On 5 June, there was a substantial increase in overall activity, although the number of JCS messages under consideration was decreasing. There were fewer incoming and outgoing messages on 6 June. There was, however, a slight increase in JCS message activity. Overall activity was decreasing on 7, 8, and 9 June with a renewal of activity around 1200 on 9 June. This point in time marked the beginning of activities concerned with the combined exercise operations.

24. Involved in every one of the days portrayed was at least some activity involved with JCS action messages. While the period of peak activity on this activity was 2 June, it is to be noted that 50 percent of all JCS messages for the entire crisis period (to 17 June) were prepared and sent during the first 4 days, i.e., 31 May through 3 June. Since this was also the period of most intense message traffic flow, these 4 days are considered the most hectic for the personnel involved. During this period there were 111 incoming messages to the JBS, each one of which involved consideration and evaluation and some of which resulted in subsequent action. There were also 29 outgoing messages (exclusive of JCS-Out messages) during this maximum activity period.

PRIMARY JOINT STAFF ACTIONS DURING THE CRISIS

ACTIONS STUDIED

25. As part of the functional analysis of Joint Staff operations during the Dominican Republic crisis, it is believed important to show how functions performed and information flow interrelated in specific Joint Staff actions. Detailed study of actions has been limited so far to those which resulted in JCS-Out messages produced by the Joint Staff.

26. Other types of "actions" performed include consideration by the Joint Staff of a large number of incoming telegraphic messages stating or implying requirements on which no formal Joint Staff actions were taken. There was a small number of "actions" which ended with decisions passed informally by upper echelons of the Joint Staff to commanders concerned. There was a series of "actions" involved in "following-up" on JCS-Out message directives, interpreting them for commanders in the field, and recording commanders orders, to indicate to the Joint Chiefs how their orders were being carried out. There was a large number of "actions" which consisted of "taking cognizance" of incoming information and recording some of it in a daily situation report. To the extent possible with data sources so far available, these are all recorded in Appendices, but it has not been practical to trace their complete histories, as has been done with the JCS-Out message "actions."

27. For all practical purposes, however, all formal Joint Staff actions are represented by the 29 JCS-Out messages produced during this crisis situation. Table III summarizes these actions, and the remainder of this section analyzes the functions involved.

~~TOP SECRET~~

~~TOP SECRET~~

TABLE III
SUMMARY OF JCS-OUT MESSAGES AND
FUNCTIONAL RESPONSIBILITIES

~~TOP SECRET~~

~~TOP SECRET~~

TABLE III
SUMMARY OF JCS-OUT MESSAGES AND FUNCTIONAL RESPONSIBILITIES

Msg. Order No.	Subject Matter	Functional Purpose	Office Originating Requirement Information	Office Ordering J/S Action	J/S Action Office	Highest Echelon &/ Approving Action	Action Time in J/S (Hours)
1	Force Readiness	Orders given CINCLANT	CIA	Vice Dir. J/S	JWR-EAB D/O	Prob. Ops. Deps.	6-1/4
2	Force Readiness	Orders given CINCLANT and Services	State-Def. Mtg.	CJCS	Vice Dir. J/S & J-3	President	16-1/4
3	Operational Assignment	Orders given CINCLANT	State-Def. Mtg.	CJCS	Vice Dir. J/S & J-3	Vice President	16-3/4
4	Operational Assignment	Orders given CINCLANT	Unknown J/S Office	Dir. J/S	JWR-EAB D/O	Dir. J/S	3-1/2
5	Force Size Planning	Orders given CINCLANT and Services	JCS	JCS	Entire JCS	Sec. Def.	24-1/4
6	Operations	Orders given CINCLANT	CINCLANT	Vice Dir. J/S	J-3	"State-Defense" (Prob. CJCS)	4-3/4
7	Operations	Orders given CINCLANT and Services	JCS	Sec. Def.	J-3	President	40-1/4
8	Logistic Support (Sealift)	Coordination Report, Channel established CINCLANT	CINCLANT	J-4	J-4	J-4	22
9	Foreign Gov't Plans	Guidance, State Mag. Readdressed CINCLANT	State-Venz. Amb.	Dir. J/S	J-2	Dir. J/S	40
10	D.R. Intelligence	Guidance, State Mag. Readdressed CINCLANT and CINCARIB	State-D.R. Consul	Dir. J/S	J-2	Dir. J/S	15
11	Foreign Gov't Plans	Orders given CINCARIB	State-Venz. Amb.	Dir. J/S	J-3	CJCS	51-1/4
12	Publicity Policy (Public Relations)	Orders given CINCLANT and Services	OSD-PA	Dir. J/S	J-3	Dir. J/S	N.A. b/
13	D.R. Intelligence	Guidance, State Mag. Readdressed CINCLANT Exclusive	State-D.R. Consul	Vice Dir. J/S	JBS-D/O	Vice Dir. J/S	29
14	Logistic Support (Sealift)	Coordination Report effected CINCLANT	CINCLANT	Dir. JBS	J-4	Dir. JBS	19
15	D.R. Intelligence	Guidance, State Mag. Readdressed CINCLANT and CINCARIB	State-D.R. Consul	Dir. JBS	JBS-D/O	Dep. Dir. J-3	4-1/4
16	D.R. Intelligence	Guidance, State Mag. Readdressed CINCLANT, CINCARIB & COMSECONDFLT	State-D.R. Consul	Dir. JBS	JBS-D/O	Dep. Dir. J-3	5-1/4
17	Operations	Orders given CINCLANT	State-Ops. Ctr.	Vice Dir. J/S	J-3	Sec. Def.	3
18	U.S. Policy	Guidance given CINCLANT Exclusive	CINCLANT	CJCS	Dir. J/S	CJCS	51-1/4
19	Operations/Plans	Authorization given CINCLANT & CINCSAC	CINCLANT	Prob. JCS	Ofc. Sec. JCS	Prob. JCS	68-1/2
20	U.S. Policy	Guidance given CINCLANT Exclusive	Sec. State	CJCS	Unknown	CJCS	N.A.
21	Plans	Guidance requested CINCLANT	CINCLANT	Dir. J/S	J-3	Dir. J/S	20-3/4
22	U.S. Policy	Guidance given CINCLANT and CINCARIB	CINCLANT	Vice Dir. J/S	J-3	Dir. J/S	49
23	Logistic Support (POL)	Report coordination effected CINCLANT	CINCLANT	J-4	J-4	J-4	27-1/4
24	Operations	Orders given CINCLANT	State-JCS Mtg.	CJCS	J-3	Sec. Def.	6-1/4
25	Plans	Authorization given CINCLANT	COMSECONDFLT	Dir. J/S	Vice Dir. J/S	CJCS	21-1/4
26	Logistic Support (Funds)	Report coordination effected CINCLANT	CINCLANT	Dep. Dir. J/S	J-3	Dir. J/S	31-1/2
27	Operations	Authorization given CINCLANT	CINCLANT	CJCS	J-3	President	45-3/4
28	Force Readiness	Orders given CINCLANT	CINCLANT	CJCS	J-3	President	46
29	Logistic Support (POL)	Report coordination effected CINCLANT	CINCLANT	J-4	J-4	J-4	44-1/2

a/ Highest echelon recorded by lower echelons. Undoubtedly some of these decisions were cleared internally by unrecorded higher echelons.
b/ N.A. - Information Not Available.

ANALYTICAL APPROACH

28. Functions involved in J/S actions have been analyzed on the assumption of four time-phased groups of functional requirements. First, there is the generation of an action requirement, involving a cause (or causal event) and a series of functions providing potential action requirement information to the Joint Staff. Second, there is a series of functions involved in establishing the requirement for action in the J/S. This involves at least a temporary decision that J/S action is desirable, and roughly what type of action should be taken and how fast. Third, there is a series of functions performed in preparing a draft action recommendation. Fourth, there is an approval phase, involving modifications of the draft action recommendation and approval at various echelons, with (finally) an order to transmit the Joint Staff action product to external offices concerned, followed by the message transmittal.

29. Subfunctions performed and time-phasing are not always the same under the groupings used. Functions involved when generation of the action requirement occurs within the J/S are quite different from those performed with external generation. Often, preparation of a draft action recommendation is begun while the formal decision to undertake J/S action is being considered. Nevertheless, the analytical format described in the following paragraphs has been found most useful in logical development of J/S actions from fragmentary and disconnected data.

30. Actions associated with each of the JCS-Out messages produced have been recorded in Appendix "B" to the extent to which data could be obtained. A format was developed within the model of functional groupings (described above) to answer a series of questions pertinent to each grouping. It has not been practical

to analyze the data pertinent to each of these questions in the study, but the purpose of Appendix "B" is to make the data available. The data groupings and the questions related to the Appendix format are listed below:

a. Action Reference

What was the subject of this J/S action and when or in what manner was it culminated?

b. Action Requirement Generation

(1) What was the basic cause of the eventual J/S action and when did the causal event occur?

(2) How was the requirement initially recognized, when and by whom?

(3) How was the potential action requirement information transmitted to the Joint Staff, when and by whom?

(4) How much time elapsed between each phase of the action requirement generation and final J/S action?

c. Establishing the Requirement

(1) How long did it take to decide on the type of J/S action desired and what was the principal time-consuming function?

(2) What office was responsible for monitoring the potential requirement and what functions were performed and liaison effected in establishing the requirement?

(3) What higher echelons were involved in determining the action requirement; in what manner was the decision made, and what was the prime factor in the decision?

d. Preparing Draft Action Recommendation

(1) How long did it take to specify the requirement, consider courses of action available, coordinate with offices concerned, and prepare an action recommendation?

(2) What offices were responsible for ordering, preparing, and supervising preparation of the draft action recommendation?

~~TOP SECRET~~

~~TOP SECRET~~

(3) How much and what type of effort was required to detail the requirement and prepare the action recommendation, and what liaison and data sources were utilized, and what type of product resulted?

e. Modification and Approval of Action Product

(1) How long did it take to review, modify, approve and transmit the J/S action product?

(2) What offices were concerned with approval of the action recommendation and what coordination and liaison were effected by the approving offices?

(3) Who was responsible for actions necessary in modifying the draft recommendation and what functions were performed?

f. Log Notes and Comments

What was the basic purpose of this message, to what extent were key developmental actions documented, and what problems were inherent in the data? (This information grouping is presented as the last page of each message collation in Appendix "B" and provides a summary of each, suitable for quick review of all JCS-Out messages sent during the DR crisis).

TIME REQUIREMENTS FOR JOINT STAFF ACTIONS

31. Before taking a close look at the individual functions involved in Joint Staff actions, it may be desirable to determine the relative efforts involved in term of time required for these functions. Table IV summarizes data available on the 29 individual actions studied.

32. Table IV requires careful interpretation. Each line of the table is an individual summary of data from Appendix "B." Unfortunately, each summary represents a different sample of the 29 actions due to unavailability of some kinds of data for every action. Since the sum of the median subfunction times is

TABLE IV

TIME^{a/} FOR FUNCTIONS INVOLVED IN JOINT STAFF ACTIONS
RESULTING IN JCS-OUT MESSAGES

Time Requirements	Sample Size (No. of Msgs.)	Median Time (Hours)	Time Range (Hours)		Longest Action
			Shortest 25% (Less Than)	Longest 25% (More Than)	
<u>To inform Joint Staff</u>					
From time of cause to time of recognition	19	3	1/4	4-3/4	116
From time of recognition to time Joint Staff informed	24	2-1/2	1-3/4	6	66
Total: From time of cause to time Joint Staff informed <u>b/</u>	21	7	2-3/4	20	120
<u>Within Joint Staff</u>					
To establish requirement	20	13	3-3/4	17	88
For draft action preparation	14	1/4	1/4	3	5-1/2
For action product approval	14	2-1/4	1/4	18	33
For action product transmittal	26	1/2	1/4	3/4	1-1/2
Total time in Joint Staff <u>b/</u>	27	22	6-1/4	45	89
<u>Total Requirement <u>b/</u></u>					
From time of cause to completion of J/S action	22	41	22	55	165
From time of recognition to completion of J/S action	24	34	19	49	89

a/ Times to nearest one-quarter hour (including time for decisions made outside Joint Staff).

b/ Values are not additive because of selective records which understate time requirements. (See text)

considerably less than the median total times recorded, it appears that subfunctions not recorded are those which take the longer times. The net result is that median subfunction times are likely understatements of actual time requirements.

33. Nevertheless, it is fairly apparent that establishing a requirement -- determining that action is required, generally what type of action and how fast action should be taken -- is the major consumer of time in the Joint Staff. Obtaining approval of draft action recommendations is the second largest time-consuming action (and is the most likely candidate for discrepancies in functions) within Joint Staff. Actually these two functions are very closely tied together in preparing JCS-Out messages, since in many cases effective final approval is obtained in the process of deciding that Joint Staff action will be taken. More detailed examination of these and other functions is made below.

GENERATION OF REQUIREMENTS INFORMATION FOR JOINT STAFF ACTION

34. Who originated what types of information which led to eventual Joint Staff actions? How long did it take to transmit requirement information to a Joint Staff office where action could be taken, and by what method of communication was it received? Table V presents available data pertinent to these questions.

35. There is nothing that seems particularly important or startling in the data of Table V. Information sources could probably be guessed if the subjects were given. The fact that almost half of the JCS actions were generated as a result of requirements established by the theater commander seems in line with the small number of JCS messages generated overall. Six of the eight State-Department-generated actions were due to

TABLE V

GENERATION OF REQUIREMENT INFORMATION
FOR JCS-OUT MESSAGES

<u>Requirement Source</u>	<u>Subject</u>	<u>No. Of Actions</u>	<u>Method Of Info. Receipt</u>	<u>Hours To Inform J/S Action Office (Min.-Max.)</u>
Joint Staff		6		
JCS	Planning For Augmented Forces	1	Debriefing	1/2
	Orders for Force Size Augmentation	1	Debriefing	1/2
Unknown Office	Recon. orders for OB info.	1	N.A.	1/2
State-Defense Meetings	Force Readiness Preparation	2	Debriefing	1-1/2
	Basic Mission Assignment	1	Debriefing	1
State Department		8		
Sec. State	U.S. Policy	1	Personal	N.A.
Field Offices	Intelligence Guidance	5	Telegrams	6 $\frac{1}{4}$ -15
	Intelligence Requirement	1	Telegrams	1-1/2
Operations Center	Prep. for Show-of-force	1	Phone Conv.	N.A.
OSD-Public Affairs Office	Revised Publicity Policy	1	Phone Conv.	N.A.
CIA	Trigger Of Contingency Plan	1	Telegram	5-1/2
Theater Commander		13		
CINCLANT	Operations Suggested	5	Telegrams	3 $\frac{1}{4}$ -54
	Logistic Support Needed	5	Telegrams	2-3/4-120 ^{a/}
	Policy Guidance Requested	2	Telegrams	1-1/2-47
COMSECONDFLT	Exercise Suggested	1	Telegrams	66 <u>a/</u>

a/ Time utilization described in text.

dependence of the Joint Staff on State for the intelligence picture in the Dominican Republic. The method of information transmittal was personal for locally generated actions, and formal, by telegram, for those generated outside the Washington area. There are indications that CINCLANT discussed some of his requirements with CNO and CJCS in telecons prior to formal communications, but these are not recorded in JBS logs.

36. The time required to notify Joint Staff action offices of requirements is largely a function of the physical location where the requirement information is generated. Locally generated requirements were phoned or brought personally to the JBS as they arose. State telegrams were sometimes screened and sent by courier to the JWR (received $1\frac{1}{2}$ to 7 hours after transmittal) and otherwise handled by normal Joint Message Center screening procedures (10 to 15 hours to the JWR). Variations in the time it took CINCLANT to send his requirements are due primarily to his own estimate of importance for speed and coordinating procedures. When CINCLANT wanted a quick reaction, his staffing and message transmittal was rapid, with four messages received in the Joint Staff less than $3\frac{1}{2}$ hours after being brought to CINCLANT's attention. Conversely, five days after CINCLANT informed MSTs by telecon to cancel a POL requirement, he requested the JCS to formally cancel the requirement. Similarly, he held up COMSECONDFLT's proposal for an exercise for $2\frac{1}{2}$ days (66- $1/4$ hours) prior to formally requesting the exercise.

ESTABLISHMENT OF REQUIREMENTS IN THE JOINT STAFF AND APPROVAL OF ACTIONS RECOMMENDED

37. As indicated previously, the processes of determining that Joint Staff action was desired, what type of action should be taken, and the degree of time and effort to be devoted to

~~TOP SECRET~~

~~TOP SECRET~~

developing the action were the major time-consuming efforts in Joint Staff actions concerning the June 1961 Dominican Republic crisis. It is extremely difficult to separate data concerning requirement establishment and action approval phases from available log records. For this reason, records for both these phases are listed as logged in Table VI. It is likely that some (and perhaps many) of the offices logged as ordering Joint Staff actions were, in fact, passing on unlogged orders from higher echelons.

38. In the requirement establishment phase of a JCS action, the action office generally brings the potential requirement information to successively higher echelons until a decision is made to do something. The decision, with guidance, is then passed successively down to the action officer. After he develops a draft action recommendation, it is similarly passed up the line for approval. After approval, recommended modifications are passed back down to the action office. In order to indicate this complete flow, the action office is noted in Table VI. Because there are many unrecorded cases of requirement establishment and action approval times, the total time in the Joint Staff is also recorded in Table VI, where available.

39. There are several points of interest in this table. The small number of "routine" actions, where the Chief JBS or J-4 can take action without going to higher echelons, is indicated. Furthermore, of the seven routine actions, two in which State messages were readdressed were based on precedence established by higher echelons in the first few days of the crisis. Unfortunately these two State messages passed directly to CINCLANT by the Chief JBS later required justification by the CJCS and were the last State messages readdressed by the J/S during the crisis.

TABLE VI

REQUIREMENT ESTABLISHMENT AND ACTION APPROVAL PHASES
FOR DOMINICAN REPUBLIC JCS-OUT MESSAGE ACTIONS

Message No.	Office Ordering Joint Staff Action	No. Of Actions Ordered	Time To Establish Requirement Hours	Time To Approve DAR Hours	Action Office	Approval Office	Subject	Time In J/S Hours
7	Sec. Def.	1	16-3/4	18	J-3	President	Force Augmentation	40-1/4
	CJCS	7						
2			13	2-3/4	J-3	President	Joint Readiness	16-1/4
3			13	3	J-3	Vice.Pres.	LANT Mission Assignment	16-3/4
18			N.A.	N.A.	Dir J/S	CJCS	U.S. Policy Guidance	51-1/4
20			N.A.	N.A.	N.A.	CJCS	U.S. Policy Guidance	N.A.
24			2	1-3/4	J-3	Sec.Def.	Decreased Readiness	6-1/4
27			9-1/4	33-1/4	J-3	President	Exercise Approval	45-3/4
28			15-3/4	28	J-3	President	Termination Of Operations	46
	JCS	2						
5			16-3/4	1	JBS	Sec.Def.	Force Augmentation	24-1/4
19			87-3/4	N.A.	Sec.JCS	JCS	LANT planning use of SAC bases	88-1/2
	Director J/S	7						
4			N.A.	N.A.	EAB D/O	Dir. J/S	Modified recon order	3-1/2
9			28	11-1/2	J-2	Dir. J/S	Readdress State Message	40
10			2-3/4	11-1/2	J-2	Dir. J/S	Readdress State Messages	40
11			N.A.	N.A.	J-3	CJCS	Orders diplomatic contact	51-1/4
12			N.A.	N.A.	J-3	Dir. J/S	Modifies publicity policy	N.A.
21			12-1/4	N.A.	J-3	Dir. J/S	Requests plans preferences	20-3/4
25			N.A.	N.A.	Vice. Dir.J/S	CJCS	Authorizes exercise planning	21-1/4
	Vice Director J/S	5						
1			5-3/4	0	EAB D/O	Ops.Deps.	Initial LANT preparations	6-1/4
6			3-1/4	N.A.	J-3	CJCS	Order ship locations	4-3/4
13			28-1/2	0	JBS D/O	Vice Dir J/S	Readdress State Messages	29
17			2-3/4	0	J-3	Sec.Def.	Orders ship location	3
22			37	N.A.	J-3	Dir. J/S	U.S. policy guidance	49
	Chief JBS	4						
14			N.A.	N.A.	J-4	Chief JBS	Logistic coord.	19
15			3-3/4	0	JBS D/O	Chief JBS	Readdress State Messages	4-1/4
16			4-1/4	0	JBS D/O	Chief JBS	Readdress State Message	5-1/4
26			1	N.A.	J-3	Dir J/S	Logistics coord.	31-1/2
	J-4	3						
8			N.A.	N.A.	J-4	J-4	Logistics coord.	22
23			N.A.	N.A.	J-4	J-4	Logistics coord.	27-1/4
29			36-1/2	N.A.	J-4	J-4	Logistics coord.	44-1/2

TABLE VI

REQUIREMENT ESTABLISHMENT AND ACTION APPROVAL PHASES
FOR DOMINICAN REPUBLIC JCS-OUT MESSAGE ACTIONS

40. The time used to establish requirements and approve action recommendations does not seem to fit any particular pattern. There are at least five cases where action approval was accomplished in the requirement establishment stage. The longest time to establish a requirement (87-3/4 hours) was spent in monitoring discussions between LANT and SAC with regard to use of Ramey AFB for Marine aircraft operations. The JCS finally stated formally the conditions for LANT use and control of SAC bases. On two occasions, 28-hour periods were used to establish requirements that State Department messages should be readdressed to CINCLANT. J-4 took 36 hours after the crisis was over to decide to inform CINCLANT that his request to cancel a POL resupply ship had been formalized.

41. The three longest recorded approval times were those where Presidential approval was obtained. It is probable that two CJCS approvals were quite lengthy (51 1/2 hours each in the J/S), and both probably required elaborate coordination with the State Department. The first two readdressings of State messages were held 11 1/2 hours for approval. State coordination was probably being effected in this period.

42. The subjects requiring top-level establishment and approval are much as would be expected. At the start of the crisis a major problem was determining how far the JCS would go on their own in implementing a nationally approved contingency plan. The problem was answered by the J/S ordering CINCLANT to prepare to implement his OPLAN with his forces only, by the Vice President with the Secretary of Defense and Secretary of State ordering force augmentation planning, and the President approving actual force augmentation orders and Joint increased readiness conditions. As previously mentioned, readdressing

~~TOP SECRET~~

State-In messages for the guidance of CINCLANT, and providing policy guidance in general, were major approval problems throughout the crisis.

ACTION ASSIGNMENTS - DEVELOPMENT OF DRAFT ACTION RECOMMENDATIONS

43. Action assignments generally consisted of monitoring the establishment of a requirement, preparing a Draft Action Recommendation (DAR), and coordinating action approval. Table VII is concerned with the development of DAR's. However, the Joint Staff action offices listed in Table VII were usually the monitoring and coordinating offices for all the Joint Staff functions performed in establishment and approval of JCS-Out messages as well. Preparation of DAR's involved specifying the requirement in detail, considering guidance or directions received as to the action desired, coordinating laterally with offices concerned, and preparing an action recommendation. Because of the very specific instructions that action offices were given during the Dominican Republic crisis, the median time for DAR preparations after actions were assigned was approximately 15 minutes. More often than not, however, action recommendations had been drafted, reviewed and modified within the JBS well before action was formally assigned. Records are too spotty to allow analysis of such preliminary draft action preparations. Many other potential actions were written up by "action" offices receiving potential action information which never resulted in formal actions.

44. Action offices were usually assigned on receipt of potential requirement information in the Joint Staff. Telegrams received by the JBS were assigned by subject matter to J-2, J-3 or J-4 for potential action. Requirements brought into the Joint Staff by general officers as the result of meetings (such

TABLE VII

DEVELOPMENT OF JOINT STAFF DRAFT ACTION RECOMMENDATIONS
FOR JCS-OUT MESSAGES

<u>Joint Staff</u> <u>Action Ofc.</u>	<u>No. of Action</u> <u>Assignments</u>	<u>No. Requiring</u> <u>More Than 30</u> <u>Min. for DAR</u> <u>Preparation</u>	<u>Action Types</u>
Ofc. Sec. JCS	1	0	As directed in JCS mtg.
Dir. J/S	1	0	Personal for CJCS
Vice Dir. J/S	3	0	As discussed in top echelon mtgs.
J-2	2	0	Selection of State msgs. for re- addressing
J-3	17	--	Misc., see text
JWR-EAB D/O	2	0	
JBS D/O	3	0	
J-3 Mbs. JBS	11	4	
Entire JBS	1	1	
J-4	4	4	Coordination with MSTS and MPSA
Unknown J/S Ofc.	1	0	Modifies JCS- approved order

~~TOP SECRET~~

as JCS or State-Defense meetings) were generally assigned to the lowest ranking officer attending the meeting. Thus, as indicated in Table VII, the Director J/S personally prepared a message for CJCS and the Vice Director J/S personally prepared three messages resulting from meetings attended with higher ranking personnel. Often, however, general officers receiving orders from their superiors would assign action to a JBS member and would sit down with the JBS to draft a message.

45. The longest times recorded for preparing and coordinating DAR's were two requiring $5\frac{1}{2}$ hours each. These resulted from detailed planning and coordination requirements generated when the JCS decided to augment the forces available for operation against the Dominican Republic. These DAR preparations resulted in specification of air support and airborne units, sealift requirements and reasonable sailing dates, along with "talking papers" for the CJCS, to brief the State Department, Secretary of Defense and Vice President on the augmentation. Three hours was required to draft a subsequent DAR authorizing an exercise, and most of this time was consumed in clearing with CINCLANT in advance. For the same reason, $2\frac{1}{2}$ hours were required to prepare the draft message "to unwind DR military operation" (i.e., clearance with CINCLANT in advance), and $1\frac{1}{2}$ hours was used to completely revert to peacetime readiness after the OPLAN exercise.

46. The only recorded times greater than half-hour for DAR preparation are noted above. However, the J-4 action (for which the JBS has no records of action phases) probably took 12 to 24 hours each to obtain coordination and the necessary data included in their messages of logistic coordination effected.

~~SECRET~~

INFORMATION FLOW

47. Information flow to, from and between Joint Staff offices has been analyzed in two phases. The first phase below is basically a "traffic analysis" of telegraphic messages filed by the June 1961 Dominican Republic JBS. All other types of JBS communications recorded in various logs are examined in the second part of this section under "Informal Joint Battle Staff Communications."

TELEGRAPHIC MESSAGE TRAFFIC

Scope and Method of Analysis

48. This analysis of the May-June 1961 Dominican Republic JBS message file is designed to indicate the nature of message traffic in terms of the operational characteristics of these messages -- rather than the contents of the messages and the significance of the contents. Research has consisted first of abstracting all messages in the JBS files; recording senders, addressees, times of origin, receipt and logging, message precedence, type of message subject and references. Abstracts were then grouped by whether they were addressed directly to the JCS or received as information copies. They were further subdivided by JBS file categories: "Military-In," "Military-Out," "State-In," and "State-Out." Within each of the preceding groups, counts of numbers of messages, and median times from origin to receipt and origin to logging, were made for each specific sender or class of sender and for each type of message subject. Arbitrary classes of message subjects were used as deemed appropriate to show significance of the messages for Joint Staff usage.

49. This section summarizes the data developed by the methods described above. It is aimed primarily at analysis of how the Joint Staff and JBS were informed as to what was

~~SECRET~~

~~SECRET~~

going on and what needed to be done. Tabular presentations are made for each grouping of message traffic, along with some verbal discussion of some of the more interesting data. Military-Out (JCS-Out) messages have been analyzed in detail in the preceding action and are only briefly reviewed here.

Summary of Telegraphic Message Traffic

50. Tables VIII and IX summarize the flow of telegraphic messages into the Washington area, listing message distribution and transmittal times respectively for pertinent incoming messages. JCS-Out messages are not included in either table and State-Out messages are not examined for transmittal times (since time into the State message center is zero).

51. Table VIII indicates that more than 90 percent of the messages describing the situation in the crisis area were received by the J/S "indirectly," rather than with the JCS as a direct addressee. Similarly, the JCS appear to be almost completely dependent on relatively informal procedures associated with determining "info copy" recipients for info as to our political moves, and more importantly, on the political and military reactions of other countries to the crisis situation.

52. Numbering sequences in the messages themselves indicate many gaps in the subject categories received as JCS info, i.e., sometimes this type of message is passed on to the JCS and sometimes it isn't. Due to direct routing of hot items directly to the JBS in some cases, and in others, informal borrowing from Service Files and War Rooms, more than one message out of five in the JBS message file did not come in by logging through the Joint War Room. These are strong inferences that some indefinite volume of message traffic of interest was never received in the Joint Staff.

~~SECRET~~

~~SECRET~~

~~SECRET~~

TABLE VIII

SUMMARY OF TELEGRAPHIC MESSAGES INCOMING TO JCS

Type Message	Military - JCS Direct Addressee	Military - JCS Info	State-In	State-Out	Totals
<u>Subject (Prime Purpose)</u>					
All Subjects - Totals (Median Hrs. from origin to logging in JWR)	65 (6½)	133 (11½)	111 (20)	31 (18½)	340 (14)
Informed J/S of crisis area situation	6	42	69	3	120
Informed J/S of U.S. military reactions to crisis situation	28	44	0	6	78
Informed J/S of political reactions to crisis situation	0	5	29	22	56
Requested J/S action or required consideration of action	31	42	13	0	86
(Number of messages unlogged)	(11)	(28)	(36)	(7)	(82)

TABLE IX
IN-MESSAGES SUMMARY

Message Handling-for-Transmittal Times

<u>Type Message and Message Precedence</u>	<u>No. a/ Messages</u>	<u>Median Time from Origin to Receipt</u>	<u>Transmittal Time Range</u>	
			<u>Fastest 25%</u>	<u>Slowest 25%</u>
<u>JCS Direct Addressee</u>				
		(In JCS Message Center)		
Emergency or Flash	2	0:48	0:38	0:57
Operational Imme- diate	28	1:08	0:14	2:06
Priority	21	2:20	0:48	3:29
Routine	5	3:16	0:07	8:34
<u>Military-JCS Info</u>				
		(In JCS Message Center)		
CRITIC	2	0:54	0:04	1:43
Emergency or Flash	7	0:43	0:19	2:06
Operational Imme- diate	45	2:35	0:57	6:02
Routine	9	3:37	1:23	19:17
Priority	26	9:44	1:15	42:03
Deferred	1	5:43	-	-
<u>State-In^{b/}</u>				
		(In State Message Center)		
NIACT	26	3.5	1.5	10.0
Oper. Immed.	9	10.0	7.5	12.5
Priority	25	2.5	2.0	6.5
Routine	29	3.5	2.0	7.0

a/ Number countable, i.e., with message precedence, time of origin, and time of receipt on JBS file copy.
b/ Times to nearest half-hour.

~~SECRET~~

53. There are factors other than message precedence which determine the time required for transmittal after origination. The times recorded in Table IX are indicative of the backlog of messages waiting transmission. The CRITIC message requiring one hour and 43 minutes for transmittal has not been explainable due to lack of clearances.

Military-In Messages -- JCS Direct Addressee

54. Table X indicates the message distributions by sender and type subjects for Military-In messages where the JCS was a direct addressee. Median times from origin to receipt and to logging are also noted.

55. Roughly half the messages received are requirements on the JCS: to coordinate actions for the theater operations, to approve operations, plans or policies, or to furnish background information or policy guidance. The other half of such messages are reports of the friendly and nonfriendly situations that prevail. Inherent in most of these reports is a requirement for Joint Staff review to determine if further JCS action is required, e.g., the theater commander has taken certain actions (does the JCS approve); the theater commander has taken certain actions (are corollary JCS actions required); theater forces will be ready in a certain number of hours (must national planning be modified to fit theater capabilities); certain nonfriendly actions have occurred (should the JCS order countermeasures).

56. There is a median lag of about five hours between time of receipt of these messages and time logged into the JWR. The median lag between time of origin and receipt is $1\frac{1}{2}$ hours.

57. Eighty percent of the messages sent to the JCS as a direct addressee were from the crisis theater commander. Of 85 messages (in the entire JBS file) sent by the theater commander's

TABLE X
MILITARY IN
JCS DIRECT ADDRESSEE

Message Distribution by Sender

<u>From</u>	<u>No. Msgs.</u>	<u>Hours: Minutes Median Times From Origin</u>	
		<u>To Receipt In JMC</u>	<u>To Logging In JWR a/</u>
CINCLANT	52	1:28	6:19
CINCLANTFLT	2		
COMSECONDFLT	2		
CINCARIB	4		
CIA	3		
CG 18th ABN Corps	1		
AMCONGEN Ciudad Trujillo	<u>1</u>	—	—
Totals	65	1:26	6:19

Message Distribution by Type Subject

No. of Messages

Nonfriendly Situation Reports (Total)	6
Requiring Action	4
Background	2
Requirements (Total)	31
For Coordinating Actions (Total)	13
Personnel	1
Logistics	8
State Dept.	2
Operations	1
Fiscal	1
For Approvals (Total)	13
Operations	6
Policy	2
Plans	5
For Guidance & Background (Total)	5
Friendly Situation Reports (Total)	28
Readiness Reports	15
Orders Given	13

a/ Time for routine traffic to be reproduced. Advance copies were forwarded on messages where "action" was obviously required.

~~SECRET~~

subordinates during the crisis and logged by the JBS, only five were sent to the JCS as a direct info addressee. This was of some importance because the greatest time delays in message transmittal occur where readdressing is required (see next section for data).

Military-In Messages -- Info Copies to JCS

58. The distribution of JCS info copies of Military-In messages is shown in Table XI, first in terms of time required for transmittal to the JWR, next in terms of sending offices, and last in terms of subject matter.

59. Roughly half of the military info copies logged by the JBS were available in the JWR less than 12 hours after origination, and approximately three-quarters in less than one day. Approximately two-thirds of these messages were generated in the action theater. There appears to be about six hours time involved in relay of messages from operational units through subordinate theater commanders to Washington as info copies.

60. Approximately ten hours delay was incurred on the average for lower echelon communications sent as info copies between receipt by Army and Navy centers in Washington and logging in the JWR. Communications from higher echelons averaged considerably less time in local transmittal to the JWR (e.g., CINCLANT's messages averaged only 3.5 hours).

61. The subjects of info copies of military messages were approximately evenly divided between commanders' requirements, info reports on friendly forces, and intelligence reports (42:44:42). Info copies of commanders' requirements for support (not requiring JCS coordination) were processed to the Pentagon faster than any other type of message. Reports concerning

TABLE XI

MILITARY-IN - INFO COPIES

1. Distribution of Times from Message Origin to Logging in JWR

<u>Hours Elapsed</u> (Inclusive)	<u>Number of Messages</u> <u>Logged in JWR</u>
1 - 11	55
12 - 23	22
24 - 35	11
36 - 47	9
48 - 59	4
60 - 71	2
72 - 95	0
> 95	2
Total	<u>105</u>

2. Message Distribution by Sender

<u>Sender</u>	<u>No. of</u> <u>Messages</u>	<u>Median Hours</u> <u>From Origin</u>		<u>No.</u> <u>Unlogged</u>
		<u>To Receipt</u> <u>In Washington^{a/}</u>	<u>To Logging</u> <u>In JWR</u>	
Theater Commander	20	2.0	5.5	2
Subordinate Theater Commanders	36	3.5	13.0	10
Operational Theater Forces	29	8.5	19.0	5
Service Staff Support Offices	21	2.0	14.0	1
Supporting Service Commands	15	5.5	13.0	6
Service Chiefs	9	0.0	8.0	3
Other Unified/ Spec. Commanders	3	-	-	1

3. Message Distribution by Type Subject (Info Copies)

<u>Subject</u>	<u>No. of</u> <u>Messages</u>	<u>Median Hours</u> <u>From Origin</u>		<u>No.</u> <u>Unlogged</u>
		<u>To Receipt</u>	<u>To Logging</u>	
Requirements	42	2.0	9	11
Friendly Situation Reports:				
Readiness	17	3.5	13	3
Movements	15	22.5	37	1
Others	12	4.0	8	3
Nonfriendly Situation Reports:				
Actions	22	3.0	12	2
Background	16	2.5	10	2
Interactions (with U.S. forces)	4	-	-	2
Message Handling	<u>5</u>			<u>4</u>
Totals	133			<u>28</u>

a/ Receipt at individual Service Message Centers

movement of ships, logistic items, and personnel were processed the slowest, averaging roughly one-day delay in message transmission, compared with two to four hours for all other subjects.

State-In Messages

62. Data pertinent to State-In messages received and filed by the JBS are summarized in Table XII. Message counts are indicated for five areas of origin of these State-In messages. Median times to receipt at the State Department and to logging in the JWR are shown, and counts by message subject are included.

TABLE XII
STATE-IN MESSAGES

<u>Origin</u>	<u>From Con- sulate in Crisis Area</u>	<u>From Em- bassies Adjacent to Crisis Area</u>	<u>From Em- bassies Outside Crisis Thtr.</u>	<u>From POLAD's^{a/} with Mil. Fcs.</u>	<u>Totals</u>
No. of Messages	70	22	9	10	111
Median Hrs. to Receipt at State	3.5	3.5	3.5	1.5	3.3
Median Hrs. from Origin to Logging in JWR	18	10	33	46	20
No. Unlogged in JWR	22	9	3	2	36
No. of Messages Describing Crisis Situation	64	1	0	4	69
No. Describing Other Countries' Reactions	1	19	9	0	29
No. Stating Requirements	5	2	0	6	13

^{a/} Political Advisers.

[REDACTED]

63. It appears that a large number of messages from the crisis area consulate were never included in the JBS file, especially after the first few days. There are no indications whether or not senior staff officers had access to additional State Dept. traffic. Screening and censoring procedures at State may have limited Joint Staff knowledge of the situation, but investigation of this subject has been deferred.

64. POLAD's messages either informed the State Department of military capabilities in the crisis area which could support potential political moves by State, or requested direct State policy guidance for the military theater commander. Unfortunately, this was a very difficult request to meet, and was handled exclusively by top echelons -- CJCS and Secretary of State. POLAD's messages were transmitted more rapidly after origination than other "State" messages (probably due to the use of military communication nets), but were the slowest in being processed to the JWR, averaging almost two days en route.

65. At the request of the State Department, embassies outside of the crisis theater reported official and press reactions in those countries to the crisis. In this particular situation, this info was negative (i.e., no strong reaction in countries outside of crisis theater) but was important to the Joint Staff in that external influences required little or no concern in military planning.

66. About 70 percent of the messages received from embassies adjacent to the crisis area (15 out of 22 messages) were of military concern in that they discussed other governments' plans for military action or planned political reactions to U.S. military moves. These messages were apparently recognized

[REDACTED]

as being of high Joint Staff interest because they were processed to the JWR much more rapidly than any other type of State message.

67. About 85 percent of the State traffic from the crisis area described the local crisis situation. About one-quarter of the messages described actions possibly calling for U.S. military reaction within some context of U.S. policy. All of these "military action" messages required policy decisions at a level higher than either the JCS or Secretary of State, and only one was in fact implemented. However, if the requests for U.S. actions made in these messages had been implemented, the messages would have provided vital background info for the military actions. The other 60 percent of the total messages from the crisis area were, from the military point of view, purely background on the personalities involved and situation reports.

State-Out Messages

68. Data concerning State-Out messages are summarized in Table XIII.

69. State-Out messages were a major source of information relative to U.S. policy towards the crisis situation, primarily in terms of State's translation of policy into action. These messages provided important information to the U.S. military forces with regard to potential military reactions of other countries, indicating what we want them to do prior to State-In messages stating what they expect to do.

70. The progress of State actions to fulfill military requirements can be followed in these messages, providing advance info as to the progress of negotiations. Some high-level military-State decisions were also reflected in these messages which do not appear in any other logged message traffic.

TABLE XIII
STATE-OUT MESSAGES

Total messages in JBS file	31
Median hours from origin to logging in JWR	18.5
Number of messages unlogged	7
Addressees:	
Crisis area consulate	17
Embassies adjacent to crisis area	12
POLAD	1
Embassies outside crisis theater	1
Subjects:	
Crisis area situation	3
Coordination of U.S. military requirements	6
Coordination of joint military actions with other countries	2
Actions concerning other countries' political reactions	11
U.S. political policy and actions	9

71. About the same amount of time was required to obtain State-Out messages as for State-In, half of them being logged 18.5 hours after origination.

JCS-Out Messages

72. Message distributions of JCS-Out messages by addressee, subject and purpose are shown in Table XIV. (These are the 29 messages analyzed in detail under "Joint Staff Actions," preceding.)

73. All messages except one were addressed to the theater commander for Dominican Republic operations. Ten of these were coaddressed as indicated in the table. The message to CINCARIB was an order to attempt to collect information as to Venezuelan plans for Dominican Republic military actions.

TABLE XIV
JCS-OUT MESSAGES

Message Distribution by Addressee

<u>Addressee</u>	<u>No. of Messages</u>	
To CINCLANT		28
"Exclusives" for CINCLANT	4	
To CINCARIB		1
With CINCLANT	3	
To Services with CINCLANT	5	
To COMSTS with CINCLANT	1	
To SAC with CINCLANT	1	
Total JCS-Out Messages		29

Message Distribution by Subject and Purpose

<u>Subject</u>	<u>Purpose</u>	<u>No. of Messages</u>	
Operations			14
Force Readiness	Orders given	3	
Mission Assignments	Orders given	6	
	Authorization	1	
Plans Revisions	Orders given	1	
	Authorization	2	
	Guidance Requested	1	
Logistic Support			5
Sealift	Report of Coordination Effected	2	
POL	Report of Coordination Effected	2	
Funding	Report of Coordination Effected	1	
Intelligence			6
Foreign Gov't Plans	Orders Collection	1	
	Guidance given	1	
Crisis Situation	Guidance given	4	
Policy			4
U.S. National Policy	Guidance given	3	
Public Relations	Guidance given	1	

~~SECRET~~

The "Exclusives for CINCLANT" were attempts to inform him of State Department actions and policy -- information which was very tightly controlled during the crisis.

74. Approximately half of the JCS-Out messages concerned operational and planning assignments. Half of these concerned specific mission assignments: do certain reconnaissance, locate ships at certain distances from shore, etc. These operational orders and authorizations are probably representative of the kinds of JCS actions needed to implement a detailed, applicable contingency plan, as are the reports of coordination effected for logistic support (17 percent of the total).

75. Very few U.S. political policy messages went out of the Joint Staff and the distribution was tightly controlled. As elaborated in the historical analysis of this crisis, there were urgent requests from the theater forces for policy guidance, and procedures for providing this guidance were inadequate. The Joint Staff had to develop procedures for policy guidance in conjunction with the State Department for each phase of contingency planning as the situations arose.

76. The intelligence support role of the Joint Staff was unusual during this crisis situation. Top echelon Joint Staff officers note that they had never had so little intelligence to work with. Further, they had not previously had to depend on State Department information as their basic intelligence source, so that channels had to be improvised. Extreme caution in use of State information is evident here, as it was with policy guidance. Intelligence for theater operations had to be passed through JCS channels, five of the six JCS-Out messages in the intelligence field being relays of State messages massed on as guidance to theater forces.

~~TOP SECRET~~

~~TOP SECRET~~

INFORMAL JOINT BATTLE STAFF COMMUNICATIONS

77. A chronological record of all recorded telephone conversations, briefings, meetings and personal contacts of members of the JBS is attached as Appendix "C". These data have been obtained from the JBS log, from notes in the message file log and on messages themselves, and from comments of members of the JBS in interviews. For each day of the crisis period each type of contact of JBS members is recorded, along with the office involved in the contact and the subject area. The part played by the JBS in the contact and subsequent actions resulting are also noted. The following subsections examine each type of informal JBS communication individually.

JBS Telephone Conversations

78. Table XV presents a summary of the number of telephone conversations that were logged in by the members of the Dominican Republic Joint Battle Staff, and provides a breakdown by the offices with which there were contacts during the crisis period.

79. This summary shows that of the 132 total telephone calls recorded, more than half of them were outgoing calls. Further, 33 calls, or 25 percent of the total, were between the JBS and CINCLANT offices.

80. Telephone calls involving other offices of the JCS, and the Navy Department, were the next highest in number with 21 being recorded for each. It might be pointed out that because of the proximity of the Joint Battle Staff to the JCS offices, many contacts made by the JBS with the Director or Vice Director of the Joint Staff, and the Director or Deputy Directors, J-3, in particular, were of the nature of informal encounters within the offices, rather than by telephone. These are included in Table XVII, "Personal Contacts".

TABLE XV

SUMMARY OF RECORDED JBS PHONE CONVERSATIONS
FROM 31 MAY THROUGH 17 JUNE, 1961

	Total Calls	JBS Outgoing Calls	JBS Incoming Calls
TOTAL NUMBER OF CALLS:	132	78	54
CINCLANT TOTAL:	33	19	14
CINCLANT Staff	9	7	2
CINCLANT Duty Officer	7	5	2
CINCLANT Plans	6	3	3
CINCLANT	4	1	3
CINCLANT Operations	2	1	1
Deputy, CINCLANT	2	-	2
CINCLANT Public Information	1	1	-
CINCLANT War Room	1	1	-
JBS Members at Norfolk	1	-	1
JCS TOTAL:	21	13	8
Director, Vice Director, J/S	9	6	3
Director, Deputy Director, J-3	8	4	4
J-2	3	2	1
Chairman's Office	1	1	-
NAVY TOTAL:	21	11	10
Navy Flag Plot	15	8	7
CNO Duty Officer	3	1	2
Miscellaneous	3	2	1
AIR FORCE TOTAL:	16	12	4
Air Force Command Post	10	7	3
Air Force Duty Officer	1	-	1
Air Force Plans	1	1	-
Tactical Air Command	1	1	-
USAF Transport Division Hdqtrs.	1	1	-
Miscellaneous	2	2	-
ARMY TOTAL:	13	10	3
Army War Room	9	7	2
Army Staff	2	1	1
Miscellaneous	2	2	-
STATE DEPARTMENT TOTAL:	10	4	6
Operations Center	9	3	6
Miscellaneous	1	1	-
SECRETARY OF DEFENSE TOTAL	4	3	1
Secretary of Defense	2	2	-
Miscellaneous	2	1	1
OTHER TOTAL:	14	6	8
White House (Gen. Clifton)	1	1	-
ISA, SAMAA Representative	6	-	6
CINCARIB	1	-	1
USMC	2	2	-
CIA	1	-	1
Miscellaneous	3	3	-

81. As might be expected, the principal JBS telephone conversations with the State Department and the Services were through their respective War Rooms. If these calls were combined, they would comprise approximately one-third of the total calls recorded. Recorded telephone calls between the Office of the Secretary of Defense, the White House, and the State Department (exclusive of the Operations Center), were few in number for the obvious reason that such contacts were more often made at a higher level and the information passed down to the members of the JBS.

JBS Conferences, Meetings and Briefings

82. Table XVI is a list of the number of conferences and meetings in which JBS members participated, and the offices which were involved, as recorded.

TABLE XVI

JBS CONFERENCES AND MEETINGS

<u>Offices Involved</u>	<u>No. of Contacts</u>
Director/Vice Director, J/S	7
Deputy Director J-3	3
Chairman, JCS	2
Special Assistant to CJCS	1
JCS Personnel	1
OSD - Public Affairs	1
USMC Attaché to DR	1
Chief of Military Mission in Haiti	<u>1</u>
TOTAL	17

83. Of the total record of 17 conferences and meetings, 14 were with offices of the JCS, and like other informal communications, it is noted that the majority of these were with the Office of the Director or Vice Director of the Joint Staff.

However, it is presumed, although not always specifically stated, that as senior members of the Joint Battle Staff, at least one of the Deputy Directors, J-3 was in attendance at these gatherings. Therefore, the three contacts listed in the Table for Deputy Directors, J-3 refer to meetings or briefings between them and members of the JBS only. The three remaining offices (other than Joint Staff) listed involved special briefings not ordinarily included in regular staff activities.

JBS Personal Contacts

84. Table XVII is a summary of the number of personal contacts appearing in available records, with the offices involved, that were made by the JBS members during the crisis period.

TABLE XVII

JBS PERSONAL CONTACTS OF RECORD

<u>Offices Involved</u>	<u>No. of Contacts</u>
Director/Vice Director J/S	18
Deputy Director, J-3	6
JCS Offices	4
White House & State Dept. Reps.	1
Secretary of Defense	1
Army War Room	1
Navy Flag Plot	1
Air Force Command Post	1
Reproduction Center	12
Message Center	2
USN Photo Interpretation Center	<u>2</u>
TOTAL	49

~~SECRET~~

~~SECRET~~

85. The majority of personal contacts recorded (28 out of a total of 49) were with offices within the JCS area, and, in particular, the Office of the Director of the Joint Staff. From the records, it appears that the Vice Director, J/S was the focal point of information flow in and out of the JBS in matters concerning top-level decisions. Thus, being conveniently near the JBS, it is to be expected that he had frequent personal encounters with them.

FINDINGS AND SUMMATION

OBSERVATIONS AND RECOMMENDATIONS OF THE DOMINICAN REPUBLIC JOINT BATTLE STAFF

86. Soon after the June 1961 JBS was dissolved, the Battle Staff members wrote a critique of their own operations. The following observations and recommendations were made:

a. Reaction times of assigned and augmentation forces are almost always briefing subjects for high-level meetings. These reaction times vary from day to day, and official statements from the action commander should be requested by plans checklists as soon as an emergency threatens and as any significant change occurs. This was done during the Dominican situation and should be SOP.

b. Details of contingency plans are requested by JCS and higher echelon personnel which are covered only in component commanders or lower echelon's plans not usually available in the Joint Staff. Such detailed briefings should be given by the commander's staff when the situation warrants. The plans checklist should provide for a briefing team or liaison officer from the CINC's to be made available to the Joint Staff for this purpose.

c. Standard format briefing book outlines should be developed now, with contents established for contingency

~~TOP SECRET~~

~~TOP SECRET~~

plans, and amended as necessary during emergencies for the Secretary of Defense, CJCS, Director J/S, and Director J-3.

d. Plans checklists should provide for potential Battle Staff members to "be briefed early and given a reading list to further read themselves into the problem."

e. Normally, transportation plans are not completed until months after approval of OPLANS. Battle Staffs should be aware that OPLANS of recent date may not have completed transportation plans and must expect to encounter problems in this area.

f. After last-minute changes to force tabs in a contingency plan, "it takes longer than you think it will" to revise supporting plans. Major problems in implementation of operational plans must be expected during the period when changes are under way.

g. Members of the Battle Staff will often be absent from battle staff duties for lengthy periods to perform briefings for the JCS. To preclude having to remove officers with operational responsibilities from the watch for briefing purposes, it is recommended that a Colonel-Captain grade officer be placed on each watch with the primary responsibility of following the situation, anticipating briefing requirements, and preparing and giving briefings. ("It should also improve the briefings.")

h. The physical facilities of the situation rooms were barely adequate for this situation, and any situation of larger scope would be difficult to administer in these facilities. (Since this time the Battle Staff Room has been enlarged and further expansion is planned.)

~~TOP SECRET~~

CONCLUDING OBSERVATIONS

87. All of the observations of the JBS critique except for the last (concerning physical facilities available) are supported by data developed in this functional analysis. (All of the DR JBS suggestions have been considered by Joint Staff offices concerned with plans for future Battle Staffs. The degree to which they have been implemented has not been ascertained in this phase of the study.) Additional observations and conclusions from each of the main sections of this study are listed below.

88. To reiterate, the purpose of this study is to present a record of Joint Staff functions performed and information flow during a crisis situation. This is a collation of previously widely separated information presented to inform people of what went on, and hopefully to allow subsequent evaluation of such crisis situation operations. This study is not an evaluation itself. Conclusions, therefore, are limited to a summation of some of the more interesting observations as to data developed and areas where additional research might be profitable.

With Regard to the Role of the Joint Staff

89. The Joint Chiefs were constrained in their direction of the military effort during this crisis by the need for coordination and approval of many of their military decisions with political authority at the State Department and White House. The reaction time of the Joint Staff was determined by these constraints, and the nature of such constraints was not immediately foreseeable. The DR JBS role was greatly influenced by these JCS-State and Presidential relationships, in that a large amount of JBS effort was required in preparation of detailed explanations of military capabilities and

~~TOP SECRET~~

~~TOP SECRET~~

potential military courses of action for high echelon coordination with political authority.

90. The largest workload for the JBS was in the first week of its existence -- the time when the Battle Staff was first formed and least experienced. The DR JBS did in fact provide a readily accessible focal point for Joint Staff handling of Dominican Republic operations. However, its creation diverted all J-3 staff work concerning this situation to the JBS area and added coordination functions for the other J's efforts to the J-3 workload.

With Regard to Functions Required for Joint Staff Actions

91. The greatest amount of time in development of Joint Staff actions was spent in deciding that certain information required J/S action and determining what type of action should be taken. The second greatest time requirement was for approval of proposed actions. Neither of these functions was performed by the JBS but both required nearly full time attention of JBS members. The JBS was usually required to draft action proposals, but this function was usually a very minor time consumer.

92. Determining what Joint Staff action was advisable and obtaining approval for action recommended required more lateral coordination, went through more echelons, and consequently took longest in the subject areas of providing policy guidance to theater forces and handling of State Department information. There was no established procedure for the Joint Staff to inform theater commanders of national policy, and no clear-cut channel for developing and passing on State-generated information as intelligence for use of theater forces. Approval by the President of key actions proposed

~~TOP SECRET~~

[REDACTED]

by the JCS sometimes took as long to obtain, but at least the method of obtaining Presidential approval seems to have been clear.

With Regard to Data Sources and Information Flow

93. The Joint Staff was very largely dependent on State Department messages for intelligence with regard to the situation in the Dominican Republic. Procurement of these messages was generally slow and there are gaps in continuity of these messages as received in the Joint Staff. State messages were also a key source of potential policy guidance information, and to some extent were used as such, by Joint Staff retransmittal to the theater commander.

94. The staff members of the JBS were completely dependent on general officers briefing them on JCS and State-Defense decisions concerning the Dominican Republic situation. The JBS had action assignments which required such information on every known higher echelon decision. Although in this particular instance, this informal method of informing JBS members as to high-level decisions reached and information circulated appears to have been fairly satisfactory, it is not clear that such would always be the case.

95. The JBS was held responsible for keeping the Joint Staff informed of intra-Service actions following through on JCS directives. The JBS was dependent upon the Services for this background information, and informal contacts with the Service War Rooms were used to lay on Joint Staff requirements. This method provided fairly complete documentation of Army and Navy actions (when coordination copies of messages were usually transmitted to Headquarters), but did not provide enough detail on Air Force actions to keep the Joint Staff informed (most of the Air Force actions being conducted

~~SECRET~~

directly between commands without information copies to Headquarters). Service information taking the longest time to reach the Joint Staff was contained in messages from subordinate to theater commanders and readdressed as info copies to headquarters or the JCS.

ADDITIONAL RESEARCH SUGGESTED

96. Three types of further research are suggested by the functional analysis of the Dominican Republic crisis. The first type is further research into data already available: to look at a few subjects which have not been examined in detail and to attempt to draw further conclusions from detailed data already developed. Analysis of J/S actions taken informally (i.e., not ending in JCS-Out messages), functions performed with incoming requirements which ended in no J/S "action" being taken, and follow-up actions on JCS-Out messages, are three examples of subjects which have not been examined in detail. The desire to produce as soon as practical a study illustrative of data development capabilities through functional analysis, has resulted in lack of time to examine many of the data included in appendices to this study. Additional research on information channels and coordination procedures for J/S actions as recorded in Appendix "B," for example, might provide additional observations of interest.

97. A second type of research indicated is the specific review of checklist procedures for contingency planning and establishment of Battle Staffs, and development of formats and procedures along lines recommended by the DR JBS critique. Preparation of briefing books for top-echelon personnel, procedures for reporting readiness of forces and briefing detailed plans, and methods for expanding battle staff personnel, appear to be areas well worth investigating.

~~SECRET~~

~~TOP SECRET~~

1

98. A third type of additional research is suggested by data gaps in information now available. Access to additional existing data would allow investigation of several known problem areas. Review of information procured and procedures utilized for screening and transmittal of info to the Joint Staff by the State Department Operations Center, Office of the Secretary of Defense, J-2, and the Service War Rooms, along with procurement of additional information from general officers and their files, are the key data sources to fill in gaps in existing information. In particular, methods used to cover crisis situations by agencies outside of the Joint Staff need to be thoroughly understood by the Joint Staff, if the Joint Staff is to take full advantage of them to save time and personnel.

~~TOP SECRET~~

~~TOP SECRET~~

APPENDIX "A"

CHRONOLOGICAL LISTING OF RECORDED
CONFERENCES AND MEETINGS AT ECHELONS
HIGHER THAN JBS CONCERNED WITH DOMINICAN REPUBLIC CRISIS

~~TOP SECRET~~

~~TOP SECRET~~

CHRONOLOGICAL LISTING OF RECORDED
CONFERENCES AND MEETINGS AT ECHELONS
HIGHER THAN JBS CONCERNED WITH DOMINICAN REPUBLIC CRISIS

<u>Date</u> 1961	<u>Time</u> (EDT)	<u>Type of Meeting</u>	<u>Participants</u>	<u>Purpose of Meeting and DR Subjects Discussed</u>	<u>Results of Meeting</u>	<u>JBS Representation</u>	<u>JBS Information Source</u>	<u>Remarks</u>
31 May	0930	Ops Deps		DR Crisis	Immediately following Ops Deps meeting, Vice Dir., J/S advised CINCLANT to be prepared to implement []	None	Vice Dir., J/S	JCS agenda. See extracts from DO log of 31 May, 1400Z
	1000	JCS		DR Crisis	Agreed on DEFCON's to be established for Navy units, as well as Army and Air Force units	?	J-3	JCS agenda
	1630	JCS		To review the basic concepts of the Contingency Plan. J-3 briefed JCS on []	Preparation for State-Defense meeting	?	J-3	
	1730	State-Defense	Vice President of U.S., Sec of State, Sec of Defense, Chairman, JCS/ Vice Dir., J/S	To consider the political and military implications of the DR crisis, and to determine what U.S. reaction was in order	Set guidance for message to CINCLANT re following 1) conditions of readiness for forces; 2) air and naval surveillance operations; 3) off-shore distances for ships; 4) aerial photoreconnaissance mission	None	Vice Dir., J/S	

Date 1961	Time (EDT)	Type of Meeting	Participants	Purpose of Meeting and DR Subjects Discussed	Results of Meeting	JBS Repre- sentation	JBS Infor- mation Source	Remarks
1 June	1030	JCS		JBS briefed JCS on support plans for DR	JCS agreed to increase combat forces and approved IANT's request for CJTF Staff augmentation.	JBS members		See Duty Ofcr. Logs. JCS meeting recorded at 1552Z
	1705	Ops Deps		To consider msg. to CINCLANT giving new guidance on [redacted] as agreed upon in 1030 JCS meeting.	Vice Dir., J/S cleared JCS msg. to CINCLANT	None	Vice Dir., J/S	
	~1915	State-Defense		To consider positioning of ships closer to shore, per JCS recommendation.	Approved reducing ships distances offshore, and directing additional outloading of forces	None	Vice Dir., J/S	
	2045	Telecon	Chairman, JCS, Chief of Naval Operations Vice Dir., J/S	Receipt of advance copies of three ship contact reports near Hispaniola	Cleared msg. to CINCLANT that reconnaissance after ships' contacts off Hispaniola should not be restricted by offshore limitations	None	Vice Dir., J/S	Telephone conference
2 June	0930 1000	Ops Deps JCS		(3 subjects)				JCS agenda JCS agenda

<u>Date</u> <u>1961</u>	<u>Time</u> <u>(EDT)</u>	<u>Type of</u> <u>Meeting</u>	<u>Participants</u>	<u>Purpose of Meeting</u> <u>and</u> <u>DR Subjects Discussed</u>	<u>Results of Meeting</u>	<u>JBS repre-</u> <u>sentation</u>	<u>JBS</u> <u>Infor-</u> <u>mation</u> <u>Source</u>	<u>Remarks</u>
2 June (Cont'd)	2330	State- Defense	Acting Sec of State Sec of Defense Chairman, JCS	To consider DR Gen's request for military aid and political implications involved	Dir., J/S said "no concrete action taken"	None	Dir., J/S	
3 June	1000	JCS	Chairman, JCS Dir., J/S Vice Dir., J/S	Review of overall DR planning with special emphasis on airborne operations planning	Chairman, JCS di- rected JBS reps. to visit Norfolk & Ft. Bragg to look into airborne planning	Deputy Directors, J-3 JBS members		
4 June	?	State		Close-in show of force	5 June, 0915-Cable by State to Venez- ambassador to con- tact Pres., Venez.	None	State Opera- tions Center	Chief West Hemisphere Branch, ISA reported this meeting would take place
5 June	?	JCS		"Probably" CINCLANT use of USAF air bases	?	?	?	JCS agenda says "JCS 2084/94 Peacetime Rules of Engagement Seaborne Forces"
	1330	JCS	JCS members Deputy Dir., J-3 JBS members	Briefing by JBS on current DR plans and augmented plan. Also briefing by J-2 and probably discussed CINCLANT use of USAF air bases	?	Deputy Dir., J-3 JBS members		

<u>Date</u> 1961	<u>Time</u> (EDT)	<u>Type of Meeting</u>	<u>Participants</u>	<u>Purpose of Meeting and DR Subjects Discussed</u>	<u>Results of Meeting</u>	<u>JBS Representation</u>	<u>JBS Information Source</u>	<u>Remarks</u>
6 June	1000	Ops Deps		"Probably" reviewed subject of CINCLANT use of USAF air bases.	?	?		JCS agenda says "9 subjects including Rule of Engagement Seaborne Forces"
	?	State	Consul Gen., CT	Review of DR situation and U.S. actions pertaining thereto.	Determined that internal DR situation seemed to be subsiding.			
7 June	1130	White House Defense	President, Chairman, JCS	Military aspects of the DR situation; U.S. military posture and its capabilities.	No action required of JBS.	None	CJCS	
	1000	JCS		SM-626-61 Items for meeting with Sec Def on 12 June.	?			JCS agenda
9 June	0930	Ops Deps		?	?	None	?	JCS agenda
	1000	JCS		?	?	None	?	JCS agenda
	1130	State-JCS		To review the DR situation and determine what appropriate military courses were indicated.	Msg. to CINCLANT to reduce readiness with constraints transmitted. Chief of Naval Operations expressed desire to hold air exercise; msg. released by Chairman indicating favorable reaction but not approval.	JBS members		JCS agenda plus logs

<u>Date</u> 1961	<u>Time</u> (EDT)	<u>Type of Meeting</u>	<u>Participants</u>	<u>Purpose of Meeting and</u> <u>DR Subjects Discussed</u>	<u>Results of Meeting</u>	<u>JBS Representation</u>	<u>JBS Information Source</u>	<u>Remarks</u>
12 June	1430	Sec Def-JCS	-	CINCLANT request for test exercise	Approved exercise plans. Prepared msg. to CINCLANT authorizing CPX and giving limitations of TAC and CONARC participations	None	?	
	1615	WH-JBS	Military Ass't to the President Deputy Director J-3	Coordination of policy details of test exercise	Military aide, WH, noted problem of invasion scare. Required notice for DR gov't.	JBS members		
13 June	0930	JCS		Test exercise	Exercise approved	None	Vice Dir., J/S	JCS agenda says 10 subjects to be discussed
14 June	0930	Ops Deps		?	?	?	?	JCS agenda
	1000	JCS		?	?	?	?	JCS agenda
15 June	1300	State-JCS		CINCLANT's request to lift DEFCON for Army & AF units	Agreed on reduction of readiness status of forces earmarked for [] Msg. sent per Chairman, JCS's clearance with Sec Def & Pres.	None	Vice Dir., J/S	

<u>Date</u> <u>1961</u>	<u>Time</u> <u>(EDT)</u>	<u>Type of</u> <u>Meeting</u>	<u>Participants</u>	<u>Purpose of Meeting</u> <u>and</u> <u>DR Subjects Discussed</u>	<u>Results of Meeting</u>	<u>JBS Repre-</u> <u>sentation</u>	<u>JBS</u> <u>Infor-</u> <u>mation</u> <u>Source</u>	<u>Remarks</u>
16 June	0930	Ops Deps		6 subjects including JCS 2304/39 (CINCLANT's Contingency Outline Plan)		?	?	JCS agenda
	1000	JCS		Same		?	?	JCS agenda
19 June	1430	Sec Def JCS		Support of Contingency Plan		?	?	JCS agenda

001

APPENDIX "B"

RECORD OF ACTIONS RELATED TO JCS OUTGOING MESSAGES

NOTE: All time recorded are Greenwich Mean Times ("Z" Time) except where otherwise noted.

APPENDIX "B"

RECORD OF ACTIONS RELATED TO JCS OUTGOING MESSAGES

TABLE OF CONTENTS

	<u>Page No.</u>
MESSAGE 1	63
LOG NOTES AND COMMENTS	65
MESSAGE 2	66
LOG NOTES AND COMMENTS	68
MESSAGE 3	69
LOG NOTES AND COMMENTS	71
MESSAGE 4	72
LOG NOTES AND COMMENTS	74
MESSAGE 5	75
LOG NOTES AND COMMENTS	77
MESSAGE 6	78
LOG NOTES AND COMMENTS	80
MESSAGE 7	81
LOG NOTES AND COMMENTS	83
MESSAGE 8	84
LOG NOTES AND COMMENTS	86
MESSAGE 9	87
LOG NOTES AND COMMENTS	89
MESSAGE 10	90
LOG NOTES AND COMMENTS	92
MESSAGE 11	93
LOG NOTES AND COMMENTS	95
MESSAGE 12	96
LOG NOTES AND COMMENTS	98
MESSAGE 13	99
LOG NOTES AND COMMENTS	101

~~TOP SECRET~~

TABLE OF CONTENTS (CONT.)

	<u>Page No.</u>
MESSAGE 14	102
LOG NOTES AND COMMENTS	104
MESSAGE 15	105
LOG NOTES AND COMMENTS	107
MESSAGE 16	108
LOG NOTES AND COMMENTS	110
MESSAGE 17	111
LOG NOTES AND COMMENTS	113
MESSAGE 18	114
LOG NOTES AND COMMENTS	116
MESSAGE 19	117
LOG NOTES AND COMMENTS	119
MESSAGE 20	120
LOG NOTES AND COMMENTS	122
MESSAGE 21	123
LOG NOTES AND COMMENTS	125
MESSAGE 22	126
LOG NOTES AND COMMENTS	128
MESSAGE 23	129
LOG NOTES AND COMMENTS	131
MESSAGE 24	132
LOG NOTES AND COMMENTS	134
MESSAGE 25	135
LOG NOTES AND COMMENTS	137

~~TOP SECRET~~

~~TOP SECRET~~

TABLE OF CONTENTS (CONT.)

	<u>Page No.</u>
MESSAGE 26	138
LOG NOTES AND COMMENTS	140
MESSAGE 27	141
LOG NOTES AND COMMENTS	143
MESSAGE 28	145
LOG NOTES AND COMMENTS	147
MESSAGE 29	148
LOG NOTES AND COMMENTS	150

~~TOP SECRET~~

JOINT STAFF ACTIONS

A. Action Reference (Msg. Order No.)

Message 1

- 1. Type Action: JCS Message
- 2. Action Subject: Orders CINCLANT to prepare to execute []
- 3. Time J/S Action Culminated: May 31 1419

B. Action Requirement Generation

- 1. Basic Cause: Trujillo's assassination triggers Contingency Plan
- 2. Time of Occurrence: May 31~ 0230
- 3. Requirement Recognition: U.S. Consul to DomRep Contacts
- 4. Recognition Source: CIA
- 5. Time of Recognition: May 31~ 0530
- 6. Time of Initial Receipt of Requirement Information in J/S: May 31~ 0800
- 7. J/S Contact Point: J-2
- 8. Hrs: Min. from Time of Cause to Time J/S Informed: 5:30
- 9. Hrs: Min. from Time of Cause to Time J/S Action Culminated: 11:49
- 10. Hrs: Min. from Time J/S Informed to Time J/S Action Culminated: 6:19

C. Establishing Requirement in J/S

- 1. Time Requirement Information Received by Action Group: 31 0800
- 2. Time Action Preparation Ordered: 31~1345
- 3. Hrs: Min. Used in Establishing Requirement: ~5:45
- 4. Principal Time-Consuming Function: Confirmation of requirement information
- 5. Initial J/S Action Assignment Point: Atlantic Div. D/O J-3
- 6. Principal Coordinating Functions Performed: Informing Dep Dir J-3 and Vice Dir J/S
- 7. Lateral Liaison -- Offices Contacted: AFCP, NFP, AWR
- 8. Higher Echelons Involved in Decision: Dep Dir J-3, Vice Dir J/S, others unknown
- 9. Type Decision: Unknown
- 10. Prime Factor in Establishing Requirement: CINCLANT Message that he had begun preparations.

7-13-62-20

D. Preparing Draft Action Recommendation (D.A.R.)

Message 1

- | | |
|---|-----------------|
| 1. Time Preparation of D.A.R. Begun: | 31~1345 |
| 2. Time Preparation of D.A.R. Formally Assigned: | 31~1345 |
| 3. Time D.A.R. Completed for Presentation: | 31~1400 |
| 4. Hrs: Min. used in Preparing D.A.R.: | ~0:15 |
| 5. Office Preparing D.A.R.: | EAB D/O |
| 6. Office Ordering D.A.R. Preparation: | Vice Dir J/S |
| 7. Office Supervising Preparation of D.A.R.: | Vice Dir J/S |
| 8. Type and No. of Personnel Assigned Action: | 1 Navy Capt |
| 9. Principal Functions Performed: | Drafted Message |
| 10. Offices Contacted in Detailing the Requirement: | Unknown |
| 11. Principal Data Source Utilized in Preparing D.A.R.: | Unknown |
| 12. Offices Contacted in Lateral Coordination: | Unknown |
| 13. Products Resulting: | JCS Message |

E. Modification and Approval of Action Product

- | | |
|---|--------------|
| 1. Time D.A.R. Submitted for Approval (to Higher Echelon Office) | Unknown |
| 2. Hrs: Min. Between Completion of D.A.R. and Consideration for Approval: | 0:00 |
| 3. Time Transmission of Approved Action Product Ordered: | 31 1400 |
| 4. Time Transmission of Approved Action Product Effected: | 31 1419 |
| 5. Hrs: Min. Between Completion of D.A.R. and Transmission of Product Effected: | ~0:34 |
| 6. Office Presenting D.A.R. for Approval: | Vice Dir J/S |
| 7. Method of Presentation of Product for Approval: | Unknown |
| 8. Offices Reviewing and Approving Action Product: | Unknown |
| 9. Offices Contacted in Coordinating Action Approval: | Unknown |
| 10. Principal Action Office for Modifying D.A.R.: | None |
| 11. Primary Modification: | None |
| 12. Principal Function Performed in Modifying D.A.R.: | None |

LOG NOTES AND COMMENTS

MESSAGE 1

1. At 31 1419Z (1019 EDT) CINCLANT is ordered to prepare to execute [] JCS order was sent by Vice Dir. J/S and written by JWR Emergency Action Branch Duty Officer (EAB D/O).

2. This order was caused by the assassination of Trujillo, reported tentatively by CRITIC msg. received 31 0400Q (D/O's Log), semiconfirmed by means of 31 1210Z (CRITIC #2), received 31 1353Z.

3. CINCLANT began preparation (on his own initiative) by loading Marines at Vieques, reported by means of CINCLANT 31 1324Z, received 31 1328Z.

4. []

5. On receipt of CRITIC #1, Vice Dir. J/S, Dep. Dir. J-3, and Service War Rooms were notified at 31 0400Q by JBS.

6. Vice Dir. J/S sent subject msg. at 1419Z. No records are available as to what occurred in the J/S during the six hours intervening.

7. Only other action in this period was by the State Dept. requesting confirmation of Trujillo's death and contacting Venezuelan and Columbian embassies for possible joint action in the DR.

8. (This message says in effect: that since CINCLANT has started backloading Marines, he should go ahead with Navy forces, but the J/S would like to be more sure of political plans (or National Level approval) before they alert other Service components.)

~~TOP SECRET~~

JOINT STAFF ACTIONS

A. Action Reference (Msg. Order No.)

Message 2

- | | |
|--------------------------------|---|
| 1. Type Action: | JCS Message |
| 2. Action Subject: | Orders Service Components of
[] to increased
readiness |
| 3. Time J/S Action Culminated: | 01 0016 June |

B. Action Requirement Generation

- | | |
|--|---|
| 1. Basic Cause: | Trujillo's assassination triggers
Contingency Plan |
| 2. Time of Occurrence: | May 31~ 0230 |
| 3. Requirement Recognition: | US Consul to DomRep Contacts |
| 4. Recognition Source: | CIA |
| 5. Time of Recognition: | May 31~ 0530 |
| 6. Time of Initial Receipt of
Requirement Information in J/S: | May 31~ 0800 |
| 7. J/S Contact Point: | J-2 |
| 8. Hrs: Min. from Time of Cause
to Time J/S Informed: | 5:30 |
| 9. Hrs: Min. from Time of Cause
to Time J/S Action Culminated: | 21:46 |
| 10. Hrs: Min. from Time J/S Informed
to Time J/S Action Culminated: | 16:16 |

C. Establishing Requirement in J/S

- | | |
|--|--|
| 1. Time Requirement Information
Received by Action Group: | 31~0800 |
| 2. Time Action Preparation Ordered: | 31~2100 |
| 3. Hrs: Min. Used in Establishing
Requirement: | ~13:00 |
| 4. Principal Time-Consuming Function: | Obtaining National policy approval |
| 5. Initial J/S Action Assignment
Point: | Vice Dir J/S |
| 6. Principal Coordinating Functions
Performed: | JCS meeting discussion |
| 7. Lateral Liaison -- Offices
Contacted: | Unknown |
| 8. Higher Echelons Involved in
Decision: | JCS, SecDef, SecState, Vice
President |
| 9. Type Decision: | State-Defense Conference Decision |
| 10. Prime Factor in Establishing
Requirement: | Previous contingency planning |

7-13-62-22

~~TOP SECRET~~

D. Preparing Draft Action Recommendation (D.A.R.)

Message 2

- 1. Time Preparation of D.A.R. Begun: 31~2100
- 2. Time Preparation of D.A.R. Formally Assigned: 31~2100
- 3. Time D.A.R. Completed for Presentation: 31~2115
- 4. Hrs: Min. used in Preparing D.A.R.: 0:15
- 5. Office Preparing D.A.R.: Dep Dir J-3
- 6. Office Ordering D.A.R. Preparation: JCS
- 7. Office Supervising Preparation of D.A.R.: Vice Dir J/S
- 8. Type and No. of Personnel Assigned Action: 1 B/Gen.
- 9. Principal Functions Performed: Attending JCS Meeting
- 10. Offices Contacted in Detailing the Requirement: JCS
- 11. Principal Data Source Utilized in Preparing D.A.R.:
- 12. Offices Contacted in Lateral Coordination: Unknown
- 13. Products Resulting: Draft Message

E. Modification and Approval of Action Product

- 1. Time D.A.R. Submitted for Approval (to Higher Echelon Office) 31 2130
- 2. Hrs: Min. Between Completion of D.A.R. and Consideration for Approval: 0:15
- 3. Time Transmission of Approved Action Product Ordered: 01 0012
- 4. Time Transmission of Approved Action Product Effected: 01 0016
- 5. Hrs: Min. Between Completion of D.A.R. and Transmission of Product Effected: 3:46
- 6. Office Presenting D.A.R. for Approval: Vice Dir J/S
- 7. Method of Presentation of Product for Approval: Conference
- 8. Offices Reviewing and Approving Action Product: CJCS, SecDef, SecState, Vice Pres.
- 9. Offices Contacted in Coordinating Action Approval: Unknown
- 10. Principal Action Office for Modifying D.A.R.: Dep Dir J-3
- 11. Primary Modification: CJCS
- 12. Principal Function Performed in Modifying D.A.R.: Review of significance of DEFCOM's

7-13-62-23

Appendix "B"

LOG NOTES AND COMMENTS

MESSAGE 2

1. At 01 0016Z(31 2016 EDT) JCS orders Service components of [] to establish revised DEFCON's. Message drafted by J-3 and submitted at 2012Q.

2. Implementation of an inter-Service OPLAN requires JCS orders to subordinate commands of forces other than CINC in charge of operations. Decision to prepare to implement OPLAN thereby generates requirement. (Whose decision this is may be ambiguous: how far can the JCS go with preparations prior to Secdef approval prior to Presidential approval?) [] had been approved with forces earmarked from all Services.

3. JCS was briefed by J-3 on [] at 2030Z. Meeting of CJCS and Vice Dir. J/S with SecDef, SecState, and Vice President of the U.S. (and others) at 2130Z. Decision was made to make all preparations for invasion of DR.

4. Note from Sec JCS to "Control Division" says that all units were to go on DEFCON 3 but "later modified". As result of JCS meeting, "Director J/S is going to draft message putting Navy units in support of [] on DEFCON 3 and Army and Air Force units on DEFCON 4" (apparently modified at State-Defense meeting).

~~TOP SECRET~~

JOINT STAFF ACTIONS

A. Action Reference (Msg. Order No.)

Message 3

- | | |
|--------------------------------|--|
| 1. Type Action: | JCS Message |
| 2. Action Subject: | Gives CINCLANT "instructions from State-Defense meeting" |
| 3. Time J/S Action Culminated: | 01 0039 |

B. Action Requirement Generation

- | | |
|---|--------------------------------|
| 1. Basic Cause: | Triggering of Contingency Plan |
| 2. Time of Occurrence: | May 31 0230 |
| 3. Requirement Recognition: | US Consul to DomRep Contacts |
| 4. Recognition Source: | CIA |
| 5. Time of Recognition: | May 31 0530 |
| 6. Time of Initial Receipt of Requirement Information in J/S: | 31 0800 |
| 7. J/S Contact Point: | J-2 |
| 8. Hrs: Min. from Time of Cause to Time J/S Informed: | 5:30 |
| 9. Hrs: Min. from Time of Cause to Time J/S Action Culminated: | 22:09 |
| 10. Hrs: Min. from Time J/S Informed to Time J/S Action Culminated: | 16:39 |

C. Establishing Requirement in J/S

- | | |
|---|--|
| 1. Time Requirement Information Received by Action Group: | 31~0800 |
| 2. Time Action Preparation Ordered: | 31~2100 |
| 3. Hrs: Min. Used in Establishing Requirement: | ~13:00 |
| 4. Principal Time-Consuming Function: | Obtaining national policy approval |
| 5. Initial J/S Action Assignment Point: | Dep Dir J-3 |
| 6. Principal Coordinating Functions Performed: | JCS meeting decision |
| 7. Lateral Liaison -- Offices Contacted: | Unknown |
| 8. Higher Echelons Involved in Decision: | JCS, SecDef, SecState, Vice Pres. |
| 9. Type Decision: | State-Defense Conf. |
| 10. Prime Factor in Establishing Requirement: | Review of 1960 Contingency Plan in view of May 1961 conditions |

7-13-62-24

Appendix "B"

~~TOP SECRET~~

D. Preparing Draft Action Recommendation (D.A.R.)

Message 3

- 1. Time Preparation of D.A.R. Begun: Unknown
- 2. Time Preparation of D.A.R. Formally Assigned: Unknown
- 3. Time D.A.R. Completed for Presentation: Unknown
- 4. Hrs: Min. used in Preparing D.A.R.: Unknown
- 5. Office Preparing D.A.R.: Atl. Div. D/O, EAB
- 6. Office Ordering D.A.R. Preparation: Vice Dir J/S
- 7. Office Supervising Preparation of D.A.R.: Dep. Dir J-3
- 8. Type and No. of Personnel Assigned Action: 1 Capt. USN
- 9. Principal Functions Performed: Debriefed Dep. Dir J-3
- 10. Offices Contacted in Detailing the Requirement: Unknown (JCS)
- 11. Principal Data Source Utilized in Preparing D.A.R.:
- 12. Offices Contacted in Lateral Coordination: Unknown
- 13. Products Resulting: Draft Message

E. Modification and Approval of Action Product

- 1. Time D.A.R. Submitted for Approval (to Higher Echelon Office) 31 2130
- 2. Hrs: Min. Between Completion of D.A.R. and Consideration for Approval: Unknown
- 3. Time Transmission of Approved Action Product Ordered: 01 0025
- 4. Time Transmission of Approved Action Product Effected: 01 0039
- 5. Hrs: Min. Between Completion of D.A.R. and Transmission of Product Effected: Unknown
- 6. Office Presenting D.A.R. for Approval: Unknown
- 7. Method of Presentation of Product for Approval: State-Defense Conference
- 8. Offices Reviewing and Approving Action Product: JCS, SecDef, SecState, Vice Pres.
- 9. Offices Contacted in Coordinating Action Approval: Unknown
- 10. Principal Action Office for Modifying D.A.R.: Unknown
- 11. Primary Modification: Unknown
- 12. Principal Function Performed in Modifying D.A.R.: Unknown

7-13-62-25

LOG NOTES AND COMMENTS

MESSAGE 3

1.

2. (Decision to prepare for invasion but not to make a show-of-force is apparent. Photorecon requirement appears to be more a decision that what is needed is information as to what is going on rather than to obtain OB and target info.)

3. Cuban situation caused first instruction. Threat from Cuba was anticipated in contingency planning. (Threat of a hostile DR military establishment had not yet been really taken into account (otherwise JCS would have insisted on more complete recon for OB purposes).)

4. Order to "report" movements from Cuba later led to defining "rules of engagement". (Decision as to what to do if Cuban forces were encountered was not made.)

5. (Cause was really Trujillo's assassination, although delay time might be played down by timing from decisions made at "State-Defense" meeting.)

~~TOP SECRET~~

JOINT STAFF ACTIONS

- A. Action Reference (Msg. Order No.) Message 4
1. Type Action: JCS Message
 2. Action Subject: Orders expanded recon of Cebao Valley
 3. Time J/S Action Culminated: 01 0212
- B. Action Requirement Generation
1. Basic Cause: OPLAN called for paratroop landings in this area. Decision to prepare to implement OPLAN called for O.B. info. Decision approved at State-Defense meeting.
 2. Time of Occurrence: 31~2215
 3. Requirement Recognition: Unknown
 4. Recognition Source: Within J/S. Exact office unknown
 5. Time of Recognition: After JCS Meeting, i.e. > 2045
 6. Time of Initial Receipt of Requirement Information in J/S: 31~2245
 7. J/S Contact Point: Vice Dir J/S
 8. Hrs: Min. from Time of Cause to Time J/S Informed: ~0:30
 9. Hrs: Min. from Time of Cause to Time J/S Action Culminated: ~4:00
 10. Hrs: Min. from Time J/S Informed to Time J/S Action Culminated: ~3:30
- C. Establishing Requirement in J/S
1. Time Requirement Information Received by Action Group: Unknown
 2. Time Action Preparation Ordered: Unknown
 3. Hrs: Min. Used in Establishing Requirement: None -- internal generation
 4. Principal Time-Consuming Function: Someone realized that planned recon of Santiago allowed coverage of Cebao Valley, where O.B. info was needed. Who realized this and who cleared the requirement are unknown.
 5. Initial J/S Action Assignment Point:
 6. Principal Coordinating Functions Performed:
 7. Lateral Liaison -- Offices Contacted: Unknown
 8. Higher Echelons Involved in Decision: Unknown
 9. Type Decision: Unknown
 10. Prime Factor in Establishing Requirement: See above

7-13-62-26

Appendix "B"

~~TOP SECRET~~

D. Preparing Draft Action Recommendation (D.A.R.)

Message 4

1. Time Preparation of D.A.R. Begun:	No records -- Unknown
2. Time Preparation of D.A.R. Formally Assigned:	" "
3. Time D.A.R. Completed for Presentation:	" "
4. Hrs: Min. used in Preparing D.A.R.:	" "
5. Office Preparing D.A.R.:	" "
6. Office Ordering D.A.R. Preparation:	" "
7. Office Supervising Preparation of D.A.R.:	" "
8. Type and No. of Personnel Assigned Action:	" "
9. Principal Functions Performed:	" "
10. Offices Contacted in Detailing the Requirement:	" "
11. Principal Data Source Utilized in Preparing D.A.R.:	" "
12. Offices Contacted in Lateral Coordination:	" "
13. Products Resulting:	" "

E. Modification and Approval of Action Product

1. Time D.A.R. Submitted for Approval (to Higher Echelon Office)	Unknown
2. Hrs: Min. Between Completion of D.A.R. and Consideration for Approval:	Unknown
3. Time Transmission of Approved Action Product Ordered:	01 0200
4. Time Transmission of Approved Action Product Effected:	01 0212
5. Hrs: Min. Between Completion of D.A.R. and Transmission of Product Effected:	Unknown
6. Office Presenting D.A.R. for Approval:	EAB D/O
7. Method of Presentation of Product for Approval:	Unknown
8. Offices Reviewing and Approving Action Product:	Dir J/S
9. Offices Contacted in Coordinating Action Approval:	Unknown
10. Principal Action Office for Modifying D.A.R.:	Unknown
11. Primary Modification:	Unknown
12. Principal Function Performed in Modifying D.A.R.:	Unknown

7-13-62-27

Appendix "B"

~~TOP SECRET~~

LOG NOTES AND COMMENTS

MESSAGE 4

1. At 01 0212Z(31 2212 EDT) Director J/S orders CINCLANT to expand morning recon to cover Cebao Valley. Message drafted at 2200 by J-3 member JBS.
2. The reason for this message is uncertain. A message receive later from C.T. (State 01 1439) reports fighting in this area. Gen. Estrella was known to be in this area and someone may have surmised a revolt by him. This area was the planned location for parachute landings to capture Santiago and split the DR. (This msg. is probably due to the OB recon requirement.)

~~TOP SECRET~~

JOINT STAFF ACTIONS

A. Action Reference (Msg. Order No.)

Message 5

- 1. Type Action:
- 2. Action Subject:
- 3. Time J/S Action Culminated:

JCS Message
 Directs augmentation of [Forces and revised
 planning necessary.
 01 2259

B. Action Requirement Generation

- 1. Basic Cause:
- 2. Time of Occurrence:
- 3. Requirement Recognition:
- 4. Recognition Source:
- 5. Time of Recognition:
- 6. Time of Initial Receipt of Requirement Information in J/S:
- 7. J/S Contact Point:
- 8. Hrs: Min. from Time of Cause to Time J/S Informed:
- 9. Hrs: Min. from Time of Cause to Time J/S Action Culminated:
- 10. Hrs: Min. from Time J/S Informed to Time J/S Action Culminated:

Original OPLAN based on premise U.S. would be asked to intervene; actual situation indicated possible vigorous opposition. Decision to prepare to intervene approved State-Defense meeting.
 31~ 2215
 Unknown
 JCS Meeting -- briefing on OPLAN and discussion.
 01~1500
 31~2245
 Vice Dir J/S
 0:30
 24:44
 24:14

C. Establishing Requirement in J/S

- 1. Time Requirement Information Received by Action Group:
- 2. Time Action Preparation Ordered:
- 3. Hrs: Min. Used in Establishing Requirement:
- 4. Principal Time-Consuming Function:
- 5. Initial J/S Action Assignment Point:
- 6. Principal Coordinating Functions Performed:
- 7. Lateral Liaison -- Offices Contacted:
- 8. Higher Echelons Involved in Decision:
- 9. Type Decision:
- 10. Prime Factor in Establishing Requirement:

01~1530
 01~1530
 None -- internal generation
 Not applicable
 Not applicable
 Not applicable
 Not applicable
 JCS
 Not applicable
 Cuban Forces inadequate

D. Preparing Draft Action Recommendation (D.A.R.)

Message 5

- | | |
|---|--|
| 1. Time Preparation of D.A.R. Begun: | 01 ~1600 |
| 2. Time Preparation of D.A.R. Formally Assigned: | 01 ~1530 |
| 3. Time D.A.R. Completed for Presentation: | 01 ~2100 |
| 4. Hrs: Min. used in Preparing D.A.R.: | 5:00 |
| 5. Office Preparing D.A.R.: | JBS |
| 6. Office Ordering D.A.R. Preparation: | Vice Dir J/S |
| 7. Office Supervising Preparation of D.A.R.: | Dep Dir J-3 |
| 8. Type and No. of Personnel Assigned Action: | No Records - Unknown (but entire JBS involved) |
| 9. Principal Functions Performed: | " " |
| 10. Offices Contacted in Detailing the Requirement: | " " |
| 11. Principal Data Source Utilized in Preparing D.A.R.: | " " |
| 12. Offices Contacted in Lateral Coordination: | " " |
| 13. Products Resulting: | Draft Message and talking paper. |

E. Modification and Approval of Action Product

- | | |
|---|----------------------|
| 1. Time D.A.R. Submitted for Approval (to Higher Echelon Office) | 01 2105 |
| 2. Hrs: Min. Between Completion of D.A.R. and Consideration for Approval: | 0:05 |
| 3. Time Transmission of Approved Action Product Ordered: | 01 2200 |
| 4. Time Transmission of Approved Action Product Effected: | 01 2259 |
| 5. Hrs: Min. Between Completion of D.A.R. and Transmission of Product Effected: | 1:59 |
| 6. Office Presenting D.A.R. for Approval: | Dep Dir J-3 |
| 7. Method of Presentation of Product for Approval: | Briefing of Ops Deps |
| 8. Offices Reviewing and Approving Action Product: | State- SecDef |
| 9. Offices Contacted in Coordinating Action Approval: | Unknown |
| 10. Principal Action Office for Modifying D.A.R.: | Unknown |
| 11. Primary Modification: | Unknown |
| 12. Principal Function Performed in Modifying D.A.R.: | Unknown |

7-13-62-29

LOG NOTES AND COMMENTS

MESSAGE 5

1. At 01 2259Z(01 1859 EDT) JCS approves LANT's request to order other Services to provide JTF commanders and directs increased force augmentation over [] in view of expected DR military resistance.

2. This message is really two separate and distinct actions. One action greatly increases the size of the forces originally called for under [] and orders plans changed accordingly. The other action orders joint Service participation under CINC-LANT. The first was caused by the JCS desire for high assurance that the force size would be adequate under the specific conditions believed to prevail in the DR. Lack of a military revolt made military resistance likely and the original plan apparently assumed that the military would not stand solidly behind Ramfis Trujillo and Balaguer.

[3.]

JOINT STAFF ACTIONS

A. Action Reference (Msg. Order No.)

Message 6

1. Type Action:
2. Action Subject:
3. Time J/S Action Culminated:

JCS Message

Authorization to CINCLANT to reduce ships distances from shore.
02 0043

B. Action Requirement Generation

1. Basic Cause:
2. Time of Occurrence:
3. Requirement Recognition:
4. Recognition Source:
5. Time of Recognition:
6. Time of Initial Receipt of Requirement Information in J/S:
7. J/S Contact Point:
8. Hrs: Min. from Time of Cause to Time J/S Informed:
9. Hrs: Min. from Time of Cause to Time J/S Action Culminated:
10. Hrs: Min. from Time J/S Informed to Time J/S Action Culminated:

CINCLANT desired to minimize reaction time. National policy was not to make show of force.

01 0039 (Orig JCS msg)
Deliberation

CINCLANT

Between 01 0039 and 01 2058

Informal call-not recorded (01~2000)
01 2253 - Formal LANT message
Probably a phone conv. between CINCLANT & Vice Dir J/S (or JCS)
Formal 22:14 (Informal probably ~20:00)
24:04

1:50 (Informal probably 4:00)

C. Establishing Requirement in J/S

1. Time Requirement Information Received by Action Group:
2. Time Action Preparation Ordered:
3. Hrs: Min. Used in Establishing Requirement:
4. Principal Time-Consuming Function:
5. Initial J/S Action Assignment Point:
6. Principal Coordinating Functions Performed:
7. Lateral Liaison -- Offices Contacted:
8. Higher Echelons Involved in Decision:
9. Type Decision:
10. Prime Factor in Establishing Requirement:

01 2253 (01 2000)

01 2315

(3:15)

Obtaining State Dept approval

Vice Dir J/S

Meeting with State Dept. officials

State Dept

CJCS

Conference

Shortened reaction potential

7-13-62-30

<u>D. Preparing Draft Action Recommendation (D.A.R.)</u>	Message 6
1. Time Preparation of D.A.R. Begun:	01 2315
2. Time Preparation of D.A.R. Formally Assigned:	01 2315
3. Time D.A.R. Completed for Presentation:	Unknown
4. Hrs: Min. used in Preparing D.A.R.:	Unknown
5. Office Preparing D.A.R.:	JBS D/O
6. Office Ordering D.A.R. Preparation:	Vice Dir J/S
7. Office Supervising Preparation of D.A.R.:	Dep Dir J-3
8. Type and No. of Personnel Assigned Action:	1 Lt. Col.
9. Principal Functions Performed:	Drafting message per instructions
10. Offices Contacted in Detailing the Requirement:	Unknown
11. Principal Data Source Utilized in Preparing D.A.R.:	LANT's 01 2058
12. Offices Contacted in Lateral Coordination:	Unknown
13. Products Resulting:	JCS Message
<u>E. Modification and Approval of Action Product</u>	
1. Time D.A.R. Submitted for Approval (to Higher Echelon Office)	Unknown
2. Hrs: Min. Between Completion of D.A.R. and Consideration for Approval:	Unknown
3. Time Transmission of Approved Action Product Ordered:	02 0039
4. Time Transmission of Approved Action Product Effected:	02 0043
5. Hrs: Min. Between Completion of D.A.R. and Transmission of Product Effected:	Unknown
6. Office Presenting D.A.R. for Approval:	Unknown
7. Method of Presentation of Product for Approval:	Unknown
8. Offices Reviewing and Approving Action Product:	Unknown
9. Offices Contacted in Coordinating Action Approval:	Unknown
10. Principal Action Office for Modifying D.A.R.:	Unknown
11. Primary Modification:	Unknown
12. Principal Function Performed in Modifying D.A.R.:	Unknown

7-13-62-31

Appendix "B"

LOG NOTES AND COMMENTS

MESSAGE 6

1. At 02 0043Z(01 2043 EDT) Vice Director J/S informs CINCLANT that he is authorized to reduce ships distance from shore to "not less than 50 miles" - as modification to JCS 01 0039 (which said one DD at 40 miles; all others at 100 miles). Message drafted by J-3 member JBS and submitted at 01 2039.

2. At 01 1915(JBS Log) Vice Dir. J/S returned from a "meeting with State" with CJCS and briefed the JBS on results. These included approval of reducing ships distance offshore.

3. CINCLANT's 01 2058 to JCS received 01 2253(01 1853 EDT) requests permission to move ships closer to shore "in order to improve reaction potential." (If Vice Director J/S visited State to discuss this message he must have had advance notice, although there is no record in log of phone conversation or other communication. This message is logged in JWR at 02 0131 marked for J-3 action. By this time reply had been sent.)

JOINT STAFF ACTIONS

A. Action Reference (Msg. Order No.)

Message 7

1. Type Action:

JCS Message

2. Action Subject:

Orders CINCLANT to sail two
CVA's and additional
Marines to Caribbean
02 1501

3. Time J/S Action Culminated:

B. Action Requirement Generation

1. Basic Cause:

National decision to prepare
to intervene

2. Time of Occurrence:

31~2215

3. Requirement Recognition:

JCS Meeting -- review of OPLAN

4. Recognition Source:

Joint Staff

5. Time of Recognition:

01~1500

6. Time of Initial Receipt of
Requirement Information in J/S:

31~2245

7. J/S Contact Point:

JCS -- Vice Dir J/S

8. Hrs: Min. from Time of Cause
to Time J/S Informed:

~0:30

9. Hrs: Min. from Time of Cause
to Time J/S Action Culminated:

40:46

10. Hrs: Min. from Time J/S Informed
to Time J/S Action Culminated:

40:16

C. Establishing Requirement in J/S

1. Time Requirement Information
Received by Action Group:

01~1530

2. Time Action Preparation Ordered:

01~1530

3. Hrs: Min. Used in Establishing
Requirement:

None -- internal generation

4. Principal Time-Consuming Function:

Not applicable

5. Initial J/S Action Assignment
Point:

Not applicable

6. Principal Coordinating Functions
Performed:

Not applicable

7. Lateral Liaison -- Offices
Contacted:

Not applicable

8. Higher Echelons Involved in
Decision:

JCS

9. Type Decision:

JCS Meeting

10. Prime Factor in Establishing
Requirement:

Desire for increased size of
immediate reaction capability

D. Preparing Draft Action Recommendation (D.A.R.)

Message 7

- | | |
|---|-----------------------------------|
| 1. Time Preparation of D.A.R. Begun: | 01~ 1600 |
| 2. Time Preparation of D.A.R. Formally Assigned: | 01~ 1530 |
| 3. Time D.A.R. Completed for Presentation: | Unknown, but earlier than 01 2100 |
| 4. Hrs: Min. used in Preparing D.A.R.: | <5:00 |
| 5. Office Preparing D.A.R.: | JBS D/O |
| 6. Office Ordering D.A.R. Preparation: | Vice Dir J/S |
| 7. Office Supervising Preparation of D.A.R.: | Dep Dir J-3 |
| 8. Type and No. of Personnel Assigned Action: | No records -- Unknown |
| 9. Principal Functions Performed: | " " |
| 10. Offices Contacted in Detailing the Requirement: | " " |
| 11. Principal Data Source Utilized in Preparing D.A.R.: | " " |
| 12. Offices Contacted in Lateral Coordination: | " " |
| 13. Products Resulting: | Draft Message and talking paper |

E. Modification and Approval of Action Product

- | | |
|---|-----------------------------|
| 1. Time D.A.R. Submitted for Approval (to Higher Echelon Office) | 01~ 2100 |
| 2. Hrs: Min. Between Completion of D.A.R. and Consideration for Approval: | Unknown |
| 3. Time Transmission of Approved Action Product Ordered: | 02 1454 |
| 4. Time Transmission of Approved Action Product Effected: | 02 1501 |
| 5. Hrs: Min. Between Completion of D.A.R. and Transmission of Product Effected: | 18:00 required for approval |
| 6. Office Presenting D.A.R. for Approval: | CJCS |
| 7. Method of Presentation of Product for Approval: | State-Defense Meeting |
| 8. Offices Reviewing and Approving Action Product: | State-SecDef-President |
| 9. Offices Contacted in Coordinating Action Approval: | Unknown |
| 10. Principal Action Office for Modifying D.A.R.: | Vice Dir J/S |
| 11. Primary Modification: | Unknown |
| 12. Principal Function Performed in Modifying D.A.R.: | Unknown |

7-13-62-33

Appendix "B"

LOG NOTES AND COMMENTS

MESSAGE 7

1. At 02 1501Z(02 1101 EDT) JCS orders two CVA's and remainder of 4th Marine Brigade to load and sail to the Caribbean for use if needed.
2. Msg. drafted by J-3 member JBS and signed by Vice Dir. J/S at 1054.
3. On 01 1915(JBS Log) Vice Dir. J/S briefed JBS on results of meeting with State including decision to "hold message concerning additional outloading of forces for Presidential approval to be given to State." (In other words, paper augmentation was approved by State-Defense meeting; actual orders to carry out augmentation required Presidential approval.)
4. On 02 1100(JBS Log) Vice Dir. J/S cleared referenced message "on direction of Secdef".

~~TOP SECRET~~

JOINT STAFF ACTIONS

A. Action Reference (Msg. Order No.)

Message 8

1. Type Action:
2. Action Subject:
3. Time J/S Action Culminated:

J/S Message

CINCLANT informed that CNO assigned action to provide MSTIS support needed by CINCLANT 02 1914

B. Action Requirement Generation

1. Basic Cause:
2. Time of Occurrence:
3. Requirement Recognition:
4. Recognition Source:
5. Time of Recognition:
6. Time of Initial Receipt of Requirement Information in J/S:
7. J/S Contact Point:
8. Hrs: Min. from Time of Cause to Time J/S Informed:
9. Hrs: Min. from Time of Cause to Time J/S Action Culminated:
10. Hrs: Min. from Time J/S Informed to Time J/S Action Culminated:

Decision to prepare to implement OPLAN generated support requirements
01 0016 (JCS directive)

Implicit in planning requirement

CNO, J/S and CINCLANT

01 0016

01 2115 LANT's specific request

J-4

~21 hours

~43 hours

~22 hours

C. Establishing Requirement in J/S

1. Time Requirement Information Received by Action Group:
2. Time Action Preparation Ordered:
3. Hrs: Min. Used in Establishing Requirement:
4. Principal Time-Consuming Function:
5. Initial J/S Action Assignment Point:
6. Principal Coordinating Functions Performed:
7. Lateral Liaison -- Offices Contacted:
8. Higher Echelons Involved in Decision:
9. Type Decision:
10. Prime Factor in Establishing Requirement:

01 ~2130

Unknown. Ordered to "hold action until morning"
At least 14 hours

Unknown

J-4 West. Hemisphere Br.
Theater Div.

Unknown

Unknown

CNO

Unknown

Desire to have CINCLANT deal with CNO rather than JCS on MSTIS matters

7-13-62-34

~~TOP SECRET~~

D. Preparing Draft Action Recommendation (D.A.R.)

Message 8

- 1. Time Preparation of D.A.R. Begun: Unknown
- 2. Time Preparation of D.A.R. Formally Assigned: Unknown
- 3. Time D.A.R. Completed for Presentation: Earlier than 02 1875
- 4. Hrs: Min. used in Preparing D.A.R.: Unknown
- 5. Office Preparing D.A.R.: J-4 Ops Branch, Transportation Div.
- 6. Office Ordering D.A.R. Preparation: Unknown
- 7. Office Supervising Preparation of D.A.R.: J-4
- 8. Type and No. of Personnel Assigned Action: Unknown
- 9. Principal Functions Performed: Unknown
- 10. Offices Contacted in Detailing the Requirement: Unknown
- 11. Principal Data Source Utilized in Preparing D.A.R.: Unknown
- 12. Offices Contacted in Lateral Coordination: Unknown
- 13. Products Resulting: Message Draft

E. Modification and Approval of Action Product

- 1. Time D.A.R. Submitted for Approval (to Higher Echelon Office) Unknown
- 2. Hrs: Min. Between Completion of D.A.R. and Consideration for Approval: Unknown
- 3. Time Transmission of Approved Action Product Ordered: 02 1825
- 4. Time Transmission of Approved Action Product Effected: 02 1914
- 5. Hrs: Min. Between Completion of D.A.R. and Transmission of Product Effected: Unknown
- 6. Office Presenting D.A.R. for Approval: Unknown
- 7. Method of Presentation of Product for Approval: Unknown
- 8. Offices Reviewing and Approving Action Product: Unknown
- 9. Offices Contacted in Coordinating Action Approval: Unknown
- 10. Principal Action Office for Modifying D.A.R.: Unknown
- 11. Primary Modification: Unknown
- 12. Principal Function Performed in Modifying D.A.R.: Unknown

LOG NOTES AND COMMENTS

MESSAGE 8

1. At 02 1914Z(02 1514 EDT) J-4 informs CINCLANT and COMSTS that CNO has been assigned action for LANT's 01 2004 (requesting MSTs forces be earmarked and ready) to support LANT's 01 2002 (giving his transport requirements in detail). Msg. written by Ops Branch, Transportation Div., J-4, submitted at 1425Q.

2. At 01 0145Z CNO had alerted COMSTS for possible shipping requirements to support JCS 996815 of 01 0016Z (establishing DEFCON's for [] forces) with info copy to CINCLANTFLT.

3. LANT's 01 2002 is to COMSTS and CNO as well as JCS and his 01 2004 lists COMSTS and CNO for info copies.

4. Follow-ups include: CNO's 02 1925 to COMSTS ordering him to prepare support requirements and constraints; COMSTS 02 2110 to CNO stating requirements, costs and degree to which shipping plans can be met (by requisitioning merchant ships); LANT's 02 2251 stating that requirements will slip and requesting JCS measures to prevent; LANT's 03 1904 to JCS asking for merchant ships; LANT's 03 1938 to JCS asking waiver of POL import quota for Puerto Rico; and JCS 03 2209 to LANT confirming D+10 delivery date for sealift.

5. (The transport requirement seems to be a cause of major concern to CINCLANT during the DR crisis.)

JOINT STAFF ACTIONS

A. Action Reference (Msg. Order No.)

Message 9

- | | |
|--------------------------------|---|
| 1. Type Action: | Transmission of State-In message for guidance of CINCLANT & CARIB |
| 2. Action Subject: | Venezuela, Paraguay and Columbia's plans for D/R action. |
| 3. Time J/S Action Culminated: | 02 2210 |

B. Action Requirement Generation

D/R Contingency Plan called for U.S. attempt to obtain OAS participation. State-Out 31 1127 requested this and State-In 31 1936 (Q) confirms.

- | | |
|---|--|
| 1. Basic Cause: | |
| 2. Time of Occurrence: | 31 ~2300 |
| 3. Requirement Recognition: | Probably discussed at 31 May State-Defense Meeting |
| 4. Recognition Source: | State |
| 5. Time of Recognition: | 01 ~0000 |
| 6. Time of Initial Receipt of Requirement Information in J/S: | 01 0608 (Logged in) |
| 7. J/S Contact Point: | J-2 |
| 8. Hrs: Min. from Time of Cause to Time J/S Informed: | ~ 7 hours |
| 9. Hrs: Min. from Time of Cause to Time J/S Action Culminated: | ~70 hours |
| 10. Hrs: Min. from Time J/S Informed to Time J/S Action Culminated: | ~40 hours |

C. Establishing Requirement in J/S

- | | |
|---|-----------------------|
| 1. Time Requirement Information Received by Action Group: | No records -- Unknown |
| 2. Time Action Preparation Ordered: | " " |
| 3. Hrs: Min. Used in Establishing Requirement: | " " |
| 4. Principal Time-Consuming Function: | " " |
| 5. Initial J/S Action Assignment Point: | " " |
| 6. Principal Coordinating Functions Performed: | " " |
| 7. Lateral Liaison -- Offices Contacted: | " " |
| 8. Higher Echelons Involved in Decision: | " " |
| 9. Type Decision: | " " |
| 10. Prime Factor in Establishing Requirement: | " " |

D. Preparing Draft Action Recommendation (D.A.R.)

Message 9

- | | |
|---|---|
| 1. Time Preparation of D.A.R. Begun: | Unknown |
| 2. Time Preparation of D.A.R. Formally Assigned: | Unknown |
| 3. Time D.A.R. Completed for Presentation: | 02 1002 |
| 4. Hrs: Min. used in Preparing D.A.R.: | Unknown |
| 5. Office Preparing D.A.R.: | J-2 |
| 6. Office Ordering D.A.R. Preparation: | Unknown |
| 7. Office Supervising Preparation of D.A.R.: | Unknown |
| 8. Type and No. of Personnel Assigned Action: | 1 Lt. Col. |
| 9. Principal Functions Performed: | Unknown |
| 10. Offices Contacted in Detailing the Requirement: | Dir J/S |
| 11. Principal Data Source Utilized in Preparing D.A.R.: | State-In Msg. No. 1175 USAMB
Venezuela, 1 June |
| 12. Offices Contacted in Lateral Coordination: | Unknown |
| 13. Products Resulting: | Readdressed Message |

E. Modification and Approval of Action Product

- | | |
|---|-------------------------------------|
| 1. Time D.A.R. Submitted for Approval (to Higher Echelon Office) | Probably 02 1002 (possibly earlier) |
| 2. Hrs: Min. Between Completion of D.A.R. and Consideration for Approval: | Uncertain |
| 3. Time Transmission of Approved Action Product Ordered: | Unknown |
| 4. Time Transmission of Approved Action Product Effected: | 02 2210 |
| 5. Hrs: Min. Between Completion of D.A.R. and Transmission of Product Effected: | 12 hours |
| 6. Office Presenting D.A.R. for Approval: | Unknown |
| 7. Method of Presentation of Product for Approval: | Unknown |
| 8. Offices Reviewing and Approving Action Product: | Dir J/S |
| 9. Offices Contacted in Coordinating Action Approval: | Unknown |
| 10. Principal Action Office for Modifying D.A.R.: | Unknown |
| 11. Primary Modification: | Unknown |
| 12. Principal Function Performed in Modifying D.A.R.: | Unknown |

7-13-62-37

Appendix "B"

LOG NOTES AND COMMENTS

MESSAGE 9

1. At 02 2210Z(02 1810 EDT) CINCLANT and CINCARIB are forwarded "Exclusive" copies of USAMB Venezuela's message No. 1175 to State (dated 1 June) discussing Venezuela, Paraguay and Columbia's plans for DR action.

2. Msg. sent by Dir. J/S and drafted by J-2 member JBS at 02 0602.

3. There are no indications in the log about receipt or re-transmission of this State message. No. 1162 from Caracas to State is in DR message log, giving original results of U.S. Ambassador's talk with Pres., Venezuela, on this subject. No. 1162 is dated May 31, 1800 and received 31 1936. Next filed msg. from Caracas is 1191, dated June 3, 1500 and received 03 1844.

4. Caracas' 1162 was due to directive of the SecState sent on 31 1127 to USAMB to send emissary to the President, Venezuela, to obtain forces to act with U.S., and through him to the President of Columbia for similar support. This msg. lays down key U.S. action policy for handling of the DR situation.

5. Apparently, this JCS message was not handled by the JBS (also true for next JCS msg.). Who advised sending it, who other than Dir. J/S approved sending it, is unknown. (Why this particular Caracas msg. was sent, rather than earlier Caracas 1162 or even earlier State-Out 31 1127, is unknown.)

~~TOP SECRET~~

JOINT STAFF ACTIONS

A. Action Reference (Msg. Order No.)

Message 10

- | | |
|--------------------------------|--|
| 1. Type Action: | Transmission of State-In Msg. |
| 2. Action Subject: | for guidance of CINCLANT & CARIB |
| 3. Time J/S Action Culminated: | Request by U.S. Consul DomRep for
immediate U.S. action to halt
"blood-bath" |
| | 02 2212 |

B. Action Requirement Generation

- | | |
|--|--------------------------------|
| 1. Basic Cause: | Fear |
| 2. Time of Occurrence: | Never, really |
| 3. Requirement Recognition: | Rumors and unconfirmed reports |
| 4. Recognition Source: | U.S. Consul Ciudad Trujillo |
| 5. Time of Recognition: | 12 0100 |
| 6. Time of Initial Receipt of
Requirement Information in J/S: | 02 0713 |
| 7. J/S Contact Point: | J-2 |
| 8. Hrs: Min. from Time of Cause
to Time J/S Informed: | Not applicable |
| 9. Hrs: Min. from Time of Cause
to Time J/S Action Culminated: | Not applicable |
| 10. Hrs: Min. from Time J/S Informed
to Time J/S Action Culminated: | 15 hours |

C. Establishing Requirement in J/S

- | | |
|--|---|
| 1. Time Requirement Information
Received by Action Group: | No records -- Unknown |
| 2. Time Action Preparation Ordered: | " " |
| 3. Hrs: Min. Used in Establishing
Requirement: | " " |
| 4. Principal Time-Consuming Function: | " " |
| 5. Initial J/S Action Assignment
Point: | " " |
| 6. Principal Coordinating Functions
Performed: | " " |
| 7. Lateral Liaison -- Offices
Contacted: | " " |
| 8. Higher Echelons Involved in
Decision: | " " |
| 9. Type Decision: | " " |
| 10. Prime Factor in Establishing
Requirement: | This message seemed to imply that
U.S. military action might be
imminent. |

7-13-62-38

~~TOP SECRET~~

D. Preparing Draft Action Recommendation (D.A.R.)

Message 10

- 1. Time Preparation of D.A.R. Begun: Unknown
- 2. Time Preparation of D.A.R. Formally Assigned: Unknown
- 3. Time D.A.R. Completed for Presentation: 02 1002
- 4. Hrs: Min. used in Preparing D.A.R.: Less than 3 hours
- 5. Office Preparing D.A.R.: J-2
- 6. Office Ordering D.A.R. Preparation: Unknown
- 7. Office Supervising Preparation of D.A.R.: Unknown
- 8. Type and No. of Personnel Assigned Action: 1 Lt. Col.
- 9. Principal Functions Performed: Dir J/S
- 10. Offices Contacted in Detailing the Requirement: State-In Msg. No. 11:9 from Ciudad Trujillo
- 11. Principal Data Source Utilized in Preparing D.A.R.: Unknown
- 12. Offices Contacted in Lateral Coordination: Unknown
- 13. Products Resulting: Readdressed Message

E. Modification and Approval of Action Product

- 1. Time D.A.R. Submitted for Approval (to Higher Echelon Office) Probably 02 1002
- 2. Hrs: Min. Between Completion of D.A.R. and Consideration for Approval: Uncertain
- 3. Time Transmission of Approved Action Product Ordered: Unknown
- 4. Time Transmission of Approved Action Product Effected: 02 2212
- 5. Hrs: Min. Between Completion of D.A.R. and Transmission of Product Effected: 12:10
- 6. Office Presenting D.A.R. for Approval: Unknown
- 7. Method of Presentation of Product for Approval: Unknown
- 8. Offices Reviewing and Approving Action Product: Dir J/S
- 9. Offices Contacted in Coordinating Action Approval: Unknown
- 10. Principal Action Office for Modifying D.A.R.: Unknown
- 11. Primary Modification: Unknown
- 12. Principal Function Performed in Modifying D.A.R.: Unknown

LOG NOTES AND COMMENTS

MESSAGE 10

1. At 02 2212Z(02 1812 EDT) Dir. J/S transmits msg. No. 1289 from U.S. Consul DR (to SecState) to CINCLANT and CINCARIB requesting immediate strong action by U.S. government to halt blood bath believed to be under way.

2. Msg. drafted by J-2 member JBS at 0602.

3. CT 1289 received 02 0713 - Log copy is burn copy of State-In message.

4. This JCS message was apparently not handled by the JBS.

5. (This particular CT msg. proved to be a badly exaggerated picture of the actual situation. A JBS member noted on the message "He's scared." - referring to the U.S. Consul.) The message was based almost completely on rumors, and was out of context with the levelheaded intelligence appraisal of the situation by the Battle Staff, even in their Sit Sum of the following morning.

JOINT STAFF ACTIONS

A. Action Reference (Msg. Order No.)

Message 11

- 1. Type Action: JCS Message
- 2. Action Subject: Orders CINCARIB to go through USEMB Venezuela to obtain Venez. plans for joint operations in D/R
- 3. Time J/S Action Culminated: 02 2248

B. Action Requirement Generation

- 1. Basic Cause: Betancourt's agreement for military commitment
- 2. Time of Occurrence: 31 1800
- 3. Requirement Recognition: USAMB discussion with Betancourt
- 4. Recognition Source: State Dept.
- 5. Time of Recognition: 31 1800
- 6. Time of Initial Receipt of Requirement Information in J/S: 31 1936
- 7. J/S Contact Point: Unknown
- 8. Hrs: Min. from Time of Cause to Time J/S Informed: 1:36
- 9. Hrs: Min. from Time of Cause to Time J/S Action Culminated: 52:48
- 10. Hrs: Min. from Time J/S Informed to Time J/S Action Culminated: 51:12

C. Establishing Requirement in J/S

- 1. Time Requirement Information Received by Action Group: Unknown
- 2. Time Action Preparation Ordered: Unknown
- 3. Hrs: Min. Used in Establishing Requirement: Unknown
- 4. Principal Time-Consuming Function: Unknown
- 5. Initial J/S Action Assignment Point: J-3
- 6. Principal Coordinating Functions Performed: Unknown
- 7. Lateral Liaison -- Offices Contacted: Unknown
- 8. Higher Echelons Involved in Decision: Unknown
- 9. Type Decision: Unknown
- 10. Prime Factor in Establishing Requirement: No details available, only generalities re Venez. participation

~~TOP SECRET~~

D. Preparing Draft Action Recommendation (D.A.R.)

Message 11

- | | |
|---|----------------------------|
| 1. Time Preparation of D.A.R. Begun: | Unknown |
| 2. Time Preparation of D.A.R. Formally Assigned: | Unknown |
| 3. Time D.A.R. Completed for Presentation: | Unknown |
| 4. Hrs: Min. used in Preparing D.A.R.: | Unknown |
| 5. Office Preparing D.A.R.: | J-3 |
| 6. Office Ordering D.A.R. Preparation: | Unknown |
| 7. Office Supervising Preparation of D.A.R.: | J-3 |
| 8. Type and No. of Personnel Assigned Action: | 1 Navy Capt. |
| 9. Principal Functions Performed: | Unknown |
| 10. Offices Contacted in Detailing the Requirement: | Unknown |
| 11. Principal Data Source Utilized in Preparing D.A.R.: | State-In 1171 from Caracas |
| 12. Offices Contacted in Lateral Coordination: | Unknown |
| 13. Products Resulting: | Draft Message |

E. Modification and Approval of Action Product

- | | |
|---|---------|
| 1. Time D.A.R. Submitted for Approval (to Higher Echelon Office) | Unknown |
| 2. Hrs: Min. Between Completion of D.A.R. and Consideration for Approval: | Unknown |
| 3. Time Transmission of Approved Action Product Ordered: | 02 2230 |
| 4. Time Transmission of Approved Action Product Effected: | 02 2248 |
| 5. Hrs: Min. Between Completion of D.A.R. and Transmission of Product Effected: | Unknown |
| 6. Office Presenting D.A.R. for Approval: | J-3 |
| 7. Method of Presentation of Product for Approval: | Unknown |
| 8. Offices Reviewing and Approving Action Product: | CJCS |
| 9. Offices Contacted in Coordinating Action Approval: | Unknown |
| 10. Principal Action Office for Modifying D.A.R.: | Unknown |
| 11. Primary Modification: | Unknown |
| 12. Principal Function Performed in Modifying D.A.R.: | Unknown |

7-13-62-41

Appendix "B"

~~TOP SECRET~~

LOG NOTES AND COMMENTS

MESSAGE 11

1. At 02 2248Z(02 1848 EDT) Dir. J/S orders CINCARIB to go through U.S. Embassy Caracas and attempt to obtain Venezuelan plans for joint operation in DR. Army to inform USAF and Navy "missions" in Caracas. State-In message 1171 from Caracas is referenced (forwarded as JCS 02 2210Z).
2. Msg. drafted by J-3 member JBS and submitted at 0643.
3. Log notes that this "message cleared by Chairman (JCS)" at 1830.
4. (The timing of this message must be analyzed in view of Caracas 1162, received 31 1936, which reports Venezuelan President's agreement for military commitment. It is likely that CJCS waited until 02 2230 to see if more details were forthcoming through the State Dept. sources. There is nothing in the JBS data to indicate that the military was pushing State on this matter, but it could be that CJCS was, prior to "clearing this message".)
5. At 03 0250 CINCARIB orders CH USA Mission Caracas to comply with JCS 02 2248Z. CARIB's answer to JCS was sent 06 1659 reporting no knowledge of Venezuelan operational plans.

JOINT STAFF ACTIONS

- | | |
|---|---|
| A. <u>Action Reference (Msg. Order No.)</u> | Message 12 |
| 1. Type Action: | JCS Message |
| 2. Action Subject: | Revised publicity policy re loading of forces for D/R OPLAN |
| 3. Time J/S Action Culminated: | 02 2249 |
| | |
| B. <u>Action Requirement Generation</u> | |
| 1. Basic Cause: | Desire not to be caught lying |
| 2. Time of Occurrence: | Initial message 02 1501 |
| 3. Requirement Recognition: | 02 1501 |
| 4. Recognition Source: | OSD-PA Office |
| 5. Time of Recognition: | Unknown |
| 6. Time of Initial Receipt of Requirement Information in J/S: | Unknown |
| 7. J/S Contact Point: | Unknown |
| 8. Hrs: Min. from Time of Cause to Time J/S Informed: | Unknown |
| 9. Hrs: Min. from Time of Cause to Time J/S Action Culminated: | 7:48 |
| 10. Hrs: Min. from Time J/S Informed to Time J/S Action Culminated: | Unknown |
| | |
| C. <u>Establishing Requirement in J/S</u> | |
| 1. Time Requirement Information Received by Action Group: | Unknown |
| 2. Time Action Preparation Ordered: | Unknown |
| 3. Hrs: Min. Used in Establishing Requirement: | Unknown |
| 4. Principal Time-Consuming Function: | Unknown |
| | |
| 5. Initial J/S Action Assignment Point: | Unknown |
| 6. Principal Coordinating Functions Performed: | Unknown |
| 7. Lateral Liaison -- Offices Contacted: | Unknown |
| 8. Higher Echelons Involved in Decision: | Unknown |
| 9. Type Decision: | Unknown |
| 10. Prime Factor in Establishing Requirement: | Unknown |

D. Preparing Draft Action Recommendation (D.A.R.)

Message 12

- 1. Time Preparation of D.A.R. Begun: Unknown
- 2. Time Preparation of D.A.R. Formally Assigned: Unknown
- 3. Time D.A.R. Completed for Presentation: Unknown
- 4. Hrs: Min. used in Preparing D.A.R.: Unknown
- 5. Office Preparing D.A.R.: JBS D/O
- 6. Office Ordering D.A.R. Preparation: Unknown
- 7. Office Supervising Preparation of D.A.R.: J-3
- 8. Type and No. of Personnel Assigned Action: 1 Navy Capt.
- 9. Principal Functions Performed: Unknown
- 10. Offices Contacted in Detailing the Requirement: Unknown
- 11. Principal Data Source Utilized in Preparing D.A.R.: JCS 02 1501
- 12. Offices Contacted in Lateral Coordination: CINCLANT D/O
- 13. Products Resulting: Draft Message

E. Modification and Approval of Action Product

- 1. Time D.A.R. Submitted for Approval (to Higher Echelon Office) Unknown
- 2. Hrs: Min. Between Completion of D.A.R. and Consideration for Approval: Unknown
- 3. Time Transmission of Approved Action Product Ordered: Prior to 02 2123
- 4. Time Transmission of Approved Action Product Effected: 02 2249
- 5. Hrs: Min. Between Completion of D.A.R. and Transmission of Product Effected: Unknown
- 6. Office Presenting D.A.R. for Approval: Unknown
- 7. Method of Presentation of Product for Approval: Unknown
- 8. Offices Reviewing and Approving Action Product: Dir J/S
- 9. Offices Contacted in Coordinating Action Approval: Unknown
- 10. Principal Action Office for Modifying D.A.R.: Unknown
- 11. Primary Modification: Unknown
- 12. Principal Function Performed in Modifying D.A.R.: Unknown

7-13-62-43

Appendix "B"

LOG NOTES AND COMMENTS

MESSAGE 12

1. At 02 2249Z(02 1849 EDT) JCS D/O for Dir. J/S advises CINCLANT and Services that queries with regard to loading CVA's and 4th Marine Brigade are to be answered by "No Comment" rather than as stated in JCS 02 1501 "Units are engaged in routine operations".

2. Msg. drafted by J-3 member JBS and submitted at 0640.

3. At 02 1723 JBS member called CINCLANT D/O and informed him of forthcoming change in JCS 02 1501.

4. This msg. was sent following a phone call from the OSD Public Affairs Office. There is nothing else in logs as to background of this msg., and no data to indicate time used in handling in J/S. (Apparently, someone wanted to be sure that the U.S. was not caught in a "prevarication".)

5. On 1 June 1840, JBS member had called CINCLANT PIO to check on LANT's policy of press releases re ship movements. (This subject was of continuing concern during the crisis.)

~~TOP SECRET~~

JOINT STAFF ACTIONS

A. Action Reference (Msg. Order No.)

Message 13

- 1. Type Action: Transmission of State-In Message for guidance of CINCLANT
- 2. Action Subject: Lists bldgs in Ciudad Trujillo which should be taken to protect U.S. interests
- 3. Time J/S Action Culminated: 03 2121

B. Action Requirement Generation

- 1. Basic Cause: Belief by U.S. Consul that U.S. military intervention is required and civilians will need immediate protection.
- 2. Time of Occurrence: 02 0100 (Time U.S. Consul requested Personal observation aid)
- 3. Requirement Recognition: U.S. Consul at C.T.
- 4. Recognition Source: 02 0400
- 5. Time of Recognition: 02 1621
- 6. Time of Initial Receipt of Requirement Information in J/S: Unknown
- 7. J/S Contact Point: 15:21
- 8. Hrs: Min. from Time of Cause to Time J/S Informed: 44:21
- 9. Hrs: Min. from Time of Cause to Time J/S Action Culminated: 29:00
- 10. Hrs: Min. from Time J/S Informed to Time J/S Action Culminated:

C. Establishing Requirement in J/S

- 1. Time Requirement Information Received by Action Group: Unknown but 02~1650
- 2. Time Action Preparation Ordered: 03 2055
- 3. Hrs: Min. Used in Establishing Requirement: ~28 hours
- 4. Principal Time-Consuming Function: Unknown
- 5. Initial J/S Action Assignment Point: JBS D/O
- 6. Principal Coordinating Functions Performed: Unknown
- 7. Lateral Liaison -- Offices Contacted: Unknown
- 8. Higher Echelons Involved in Decision: Vice Dir J/S
- 9. Type Decision: Unknown
- 10. Prime Factor in Establishing Requirement: Request by Navy for CINCLANT to be included as addressee for important State Dept. traffic.

7-13-62-44

~~TOP SECRET~~

~~TOP SECRET~~

D. Preparing Draft Action Recommendation (D.A.R.)

Message 13

- | | |
|---|--------------------------------|
| 1. Time Preparation of D.A.R. Begun: | Unknown |
| 2. Time Preparation of D.A.R. Formally Assigned: | 03 2055 |
| 3. Time D.A.R. Completed for Presentation: | Unknown |
| 4. Hrs: Min. used in Preparing D.A.R.: | Unknown |
| 5. Office Preparing D.A.R.: | JBS D/O |
| 6. Office Ordering D.A.R. Preparation: | Vice Dir J/S |
| 7. Office Supervising Preparation of D.A.R.: | Dep Dir J-3 |
| 8. Type and No. of Personnel Assigned Action: | 1 Navy Capt. |
| 9. Principal Functions Performed: | Unknown |
| 10. Offices Contacted in Detailing the Requirement: | Unknown |
| 11. Principal Data Source Utilized in Preparing D.A.R.: | State-In C.T. 1290 |
| 12. Offices Contacted in Lateral Coordination: | Unknown |
| 13. Products Resulting: | Exclusive Message for CINCLANT |

E. Modification and Approval of Action Product

- | | |
|---|--------------|
| 1. Time D.A.R. Submitted for Approval (to Higher Echelon Office) | Unknown |
| 2. Hrs: Min. Between Completion of D.A.R. and Consideration for Approval: | Unknown |
| 3. Time Transmission of Approved Action Product Ordered: | 03 2055 |
| 4. Time Transmission of Approved Action Product Effected: | 03 2121 |
| 5. Hrs: Min. Between Completion of D.A.R. and Transmission of Product Effected: | Unknown |
| 6. Office Presenting D.A.R. for Approval: | Unknown |
| 7. Method of Presentation of Product for Approval: | Unknown |
| 8. Offices Reviewing and Approving Action Product: | Vice Dir J/S |
| 9. Offices Contacted in Coordinating Action Approval: | Unknown |
| 10. Principal Action Office for Modifying D.A.R.: | Unknown |
| 11. Primary Modification: | Unknown |
| 12. Principal Function Performed in Modifying D.A.R.: | Unknown |

7-13-62-45

LOG NOTES AND COMMENTS

MESSAGE 13

1. At 03 2121Z(03 1721 EDT) Vice Dir. J/S sends an "Exclusive" for CINCLANT passing on CT 1290 "for action if required". CT 1290 lists buildings in CT which should be taken immediately by air drop to protect U.S. interests in case of U.S. invasion. CT 1290 dated midnight June 1 is marked "received 2 June 12:21 PM"

2. JCS 03 2121 was written by a J-3 member of JBS. Log notes that at 1655 Vice Dir. J/S called JBS and ordered passing above msg. to CINCLANT.

3. No record of who brought this to Vice Director's attention or when. (It may have been discussed at State-Defense meeting 2 June 2330.)

~~TOP SECRET~~

JOINT STAFF ACTIONS

A. Action Reference (Msg. Order No.)

Message 14

- | | |
|--------------------------------|---|
| 1. Type Action: | JCS Message |
| 2. Action Subject: | Informs CINCLANT that MSTTS confirms D+10 delivery date for sea lift. |
| 3. Time J/S Action Culminated: | 03 2209 |

B. Action Requirement Generation

- | | |
|---|---|
| 1. Basic Cause: | LANT message noting that MSTTS expects slippage and asking for JCS action |
| 2. Time of Occurrence: | 02 ~2000 |
| 3. Requirement Recognition: | LANT telecon with MSTTS |
| 4. Recognition Source: | LANT |
| 5. Time of Recognition: | 02 2251 (Time of LANT message) |
| 6. Time of Initial Receipt of Requirement Information in J/S: | 03 0309 (Time message received) |
| 7. J/S Contact Point: | JBS D/O |
| 8. Hrs: Min. from Time of Cause to Time J/S Informed: | ~7 hours |
| 9. Hrs: Min. from Time of Cause to Time J/S Action Culminated: | ~26 hours |
| 10. Hrs: Min. from Time J/S Informed to Time J/S Action Culminated: | 19:00 |

C. Establishing Requirement in J/S

- | | |
|---|----------------|
| 1. Time Requirement Information Received by Action Group: | 03 ~0330 |
| 2. Time Action Preparation Ordered: | Unknown |
| 3. Hrs: Min. Used in Establishing Requirement: | Unknown |
| 4. Principal Time-Consuming Function: | Unknown |
| 5. Initial J/S Action Assignment Point: | J-4 Member JBS |
| 6. Principal Coordinating Functions Performed: | Unknown |
| 7. Lateral Liaison -- Offices Contacted: | J-4 and MPSA |
| 8. Higher Echelons Involved in Decision: | Dep Dir J-3 |
| 9. Type Decision: | Unknown |
| 10. Prime Factor in Establishing Requirement: | Unknown |

7-13-62-46

Appendix "B"

D. Preparing Draft Action Recommendation (D.A.R.)

Message 14

- 1. Time Preparation of D.A.R. Begun: Unknown
- 2. Time Preparation of D.A.R. Formally Assigned: Unknown
- 3. Time D.A.R. Completed for Presentation: Unknown
- 4. Hrs: Min. used in Preparing D.A.R.: Unknown
- 5. Office Preparing D.A.R.: J-4 Member JBS
- 6. Office Ordering D.A.R. Preparation: Dep Dir J-3
- 7. Office Supervising Preparation of D.A.R.: Dep Dir J-3
- 8. Type and No. of Personnel Assigned Action: 1 Lt. Cdr.
- 9. Principal Functions Performed: Unknown
- 10. Offices Contacted in Detailing the Requirement: Unknown
- 11. Principal Data Source Utilized in Preparing D.A.R.: Unknown
- 12. Offices Contacted in Lateral Coordination: MSTS
- 13. Products Resulting: Message Draft

E. Modification and Approval of Action Product

- 1. Time D.A.R. Submitted for Approval (to Higher Echelon Office) Unknown
- 2. Hrs: Min. Between Completion of D.A.R. and Consideration for Approval: Unknown
- 3. Time Transmission of Approved Action Product Ordered: Unknown
- 4. Time Transmission of Approved Action Product Effected: 03 2209
- 5. Hrs: Min. Between Completion of D.A.R. and Transmission of Product Effected: Unknown
- 6. Office Presenting D.A.R. for Approval: Unknown
- 7. Method of Presentation of Product for Approval: Unknown
- 8. Offices Reviewing and Approving Action Product: Dep Dir J-3
- 9. Offices Contacted in Coordinating Action Approval: Unknown
- 10. Principal Action Office for Modifying D.A.R.: Unknown
- 11. Primary Modification: Unknown
- 12. Principal Function Performed in Modifying D.A.R.: Unknown

7-13-62-47

LOG NOTES AND COMMENTS

MESSAGE 14

1. At 03 2209Z(03 1809 EDT) acting J-3 answers CINCLANT's 02 2251 by stating that MSTS confirms D+10 delivery date for sealift even with slippage of loading dates.
2. Msg. drafted by J-4 member JBS, signing as member of "JWR" - no time listed. JCS D/O signed for Chief, JBS.
3. LANT's 02 2251 states that telecon with MSTS staff indicates possible slippage, and "recommends appropriate action be taken to assure fulfillment all transportation requirements on schedule". Action on this assigned to J-4. Msg. received 03 0309Z. Three previous LANT msgs. concerning sealift are referenced (see JCS-Out msg. 02 1914Z).
4. Prior to this JCS message being sent, two more LANT msgs. to JCS were received on this subject. LANT's 03 1904 recommends making commercial ships available to meet OPLAN requirements, and LANT's 03 1938 recommends waiver of POL import quota for Puerto Rico if OPLAN is implemented - J-3 assigned action for both these two messages. Notes on latter message says "J-4 notified 2100 R" and "call Capt. Chubb MPSA".

JOINT STAFF ACTIONS

A. Action Reference (Msg. Order No.)

Message 15

- | | |
|--------------------------------|---|
| 1. Type Action: | Readdress of State-In Message to CINCLANT & CARIB |
| 2. Action Subject: | Plans to resist attack on U.S. Consulate at Ciudad Trujillo |
| 3. Time J/S Action Culminated: | 04 ~1535 |

B. Action Requirement Generation

- | | |
|---|------------------------------------|
| 1. Basic Cause: | Fear and conscience |
| 2. Time of Occurrence: | Indefinite |
| 3. Requirement Recognition: | Indefinite |
| 4. Recognition Source: | U.S. Consul Ciudad Trujillo |
| 5. Time of Recognition: | 04 0100 (Time C.T. 1318 addressed) |
| 6. Time of Initial Receipt of Requirement Information in J/S: | 04 1120 |
| 7. J/S Contact Point: | J-2 |
| 8. Hrs: Min. from Time of Cause to Time J/S Informed: | 10:20 (From recognition) |
| 9. Hrs: Min. from Time of Cause to Time J/S Action Culminated: | 14:35 (From recognition) |
| 10. Hrs: Min. from Time J/S Informed to Time J/S Action Culminated: | 4:15 |

C. Establishing Requirement in J/S

- | | |
|---|---|
| 1. Time Requirement Information Received by Action Group: | 04 ~1130 |
| 2. Time Action Preparation Ordered: | 04 1511 |
| 3. Hrs: Min. Used in Establishing Requirement: | 3:41 |
| 4. Principal Time-Consuming Function: | Unknown |
| 5. Initial J/S Action Assignment Point: | J-2 |
| 6. Principal Coordinating Functions Performed: | Unknown |
| 7. Lateral Liaison -- Offices Contacted: | JBS D/O |
| 8. Higher Echelons Involved in Decision: | Dep Dir J-3 |
| 9. Type Decision: | Unknown |
| 10. Prime Factor in Establishing Requirement: | Navy Op-61 request for such info and J-2 suggestion |

7-13-62-48

D. Preparing Draft Action Recommendation (D.A.R.)

Message 15

- | | |
|---|---------------------|
| 1. Time Preparation of D.A.R. Begun: | Unknown |
| 2. Time Preparation of D.A.R. Formally Assigned: | 04 1511 |
| 3. Time D.A.R. Completed for Presentation: | Unknown |
| 4. Hrs: Min. used in Preparing D.A.R.: | Unknown |
| 5. Office Preparing D.A.R.: | JBS |
| 6. Office Ordering D.A.R. Preparation: | Dep Dir J-3 |
| 7. Office Supervising Preparation of D.A.R.: | Dep Dir J-3 |
| 8. Type and No. of Personnel Assigned Action: | Unknown |
| 9. Principal Functions Performed: | Unknown |
| 10. Offices Contacted in Detailing the Requirement: | ISA, J-2 |
| 11. Principal Data Source Utilized in Preparing D.A.R.: | State-In C.T. 1318 |
| 12. Offices Contacted in Lateral Coordination: | Unknown |
| 13. Products Resulting: | Readdressed Message |

E. Modification and Approval of Action Product

- | | |
|---|-------------|
| 1. Time D.A.R. Submitted for Approval (to Higher Echelon Office) | 04 1415 |
| 2. Hrs: Min. Between Completion of D.A.R. and Consideration for Approval: | Unknown |
| 3. Time Transmission of Approved Action Product Ordered: | 04 1511 |
| 4. Time Transmission of Approved Action Product Effected: | 04 ~1535 |
| 5. Hrs: Min. Between Completion of D.A.R. and Transmission of Product Effected: | ~0:24 |
| 6. Office Presenting D.A.R. for Approval: | J-2 |
| 7. Method of Presentation of Product for Approval: | Unknown |
| 8. Offices Reviewing and Approving Action Product: | Dep Dir J-3 |
| 9. Offices Contacted in Coordinating Action Approval: | Unknown |
| 10. Principal Action Office for Modifying D.A.R.: | Unknown |
| 11. Primary Modification: | Unknown |
| 12. Principal Function Performed in Modifying D.A.R.: | Unknown |

LOG NOTES AND COMMENTS

MESSAGE 15

Unfiled JCS-Approved Transmission: Reference JBS Log

1. 04 1111(log time) Chief JBS gave permission to readdress State 1318 to CINCLANT and CINCARIB.
2. 04 1130 JBS directed Msg. Ctr. to send State 1318.
3. CT 1318 is dated 3 June 2100 and received 04 1120Z, addressed to SecState with info copy to OSD. Message describes expected implication of U.S. in assassination plot and plans to resist possible attacks on the consulate.
4. 3 June 1020 Navy Op-61 requested JBS to add CINCLANT and COMSECONDFLT as addressees on pertinent State traffic. JBS D/O discussed this request with Vice Director J/S who called military liaison officer at State Op Ctr. - no record of decision. 4 June 0835, Chief Western Hemisphere Branch of ISA called JBS re CT 1318. At 1015 J-2 called re readdressing CT 1318.
5. CJCS requested copies of this and following message after they had been readdressed. (It is interesting that no more State messages are readdressed after this.)

~~TOP SECRET~~

JOINT STAFF ACTIONS

A. Action Reference (Msg. Order No.)

Message 16

1. Type Action: Readdress of State-In Message to CINCLANT & CARIB
2. Action Subject: Reports disorder in N.W. DomRep and suggests high altitude recon
3. Time J/S Action Culminated: 04 ~1900

B. Action Requirement Generation

1. Basic Cause: Unconfirmed reports
2. Time of Occurrence: Indefinite
3. Requirement Recognition: Indefinite
4. Recognition Source: U.S. Consul Ciudad Trujillo
5. Time of Recognition: 04 0100 (Time C.T. 1321 addressed)
6. Time of Initial Receipt of Requirement Information in J/S: 04 1348
7. J/S Contact Point: Probably J-2
8. Hrs: Min. from Time of Cause to Time J/S Informed: 12:48 (From recognition)
9. Hrs: Min. from Time of Cause to Time J/S Action Culminated: 18:00 (From recognition)
10. Hrs: Min. from Time J/S Informed to Time J/S Action Culminated: 5:12

C. Establishing Requirement in J/S

1. Time Requirement Information Received by Action Group: 04 1348
2. Time Action Preparation Ordered: 04 1758
3. Hrs: Min. Used in Establishing Requirement: 4:10
4. Principal Time-Consuming Function: Unknown
5. Initial J/S Action Assignment Point: Probably J-2
6. Principal Coordinating Functions Performed: Unknown
7. Lateral Liaison -- Offices Contacted: NFP, Vice CNO
8. Higher Echelons Involved in Decision: Unknown
9. Type Decision: Unknown
10. Prime Factor in Establishing Requirement: Unknown

7-13-62-50

Appendix "B"

~~TOP SECRET~~

D. Preparing Draft Action Recommendation (D.A.R.)

Message 16

- 1. Time Preparation of D.A.R. Begun: Unknown
- 2. Time Preparation of D.A.R. Formally Assigned: 04 1758
- 3. Time D.A.R. Completed for Presentation: Unknown
- 4. Hrs: Min. used in Preparing D.A.R.: Unknown
- 5. Office Preparing D.A.R.: JBS
- 6. Office Ordering D.A.R. Preparation: Unknown
- 7. Office Supervising Preparation of D.A.R.: Probably Dep Dir J-3
- 8. Type and No. of Personnel Assigned Action: Unknown
- 9. Principal Functions Performed: Unknown
- 10. Offices Contacted in Detailing the Requirement: NFP, Vice CNO
- 11. Principal Data Source Utilized in Preparing D.A.R.: State-In C.T. 1321
- 12. Offices Contacted in Lateral Coordination: Unknown
- 13. Products Resulting: Readdressed Message

E. Modification and Approval of Action Product

- 1. Time D.A.R. Submitted for Approval (to Higher Echelon Office) Unknown
- 2. Hrs: Min. Between Completion of D.A.R. and Consideration for Approval: Unknown
- 3. Time Transmission of Approved Action Product Ordered: 04 1758
- 4. Time Transmission of Approved Action Product Effected: 04 ~1900
- 5. Hrs: Min. Between Completion of D.A.R. and Transmission of Product Effected: ~1 hour
- 6. Office Presenting D.A.R. for Approval: Unknown
- 7. Method of Presentation of Product for Approval: Unknown
- 8. Offices Reviewing and Approving Action Product: Unknown
- 9. Offices Contacted in Coordinating Action Approval: NFP, Vice CNO
- 10. Principal Action Office for Modifying D.A.R.: JBS D/O
- 11. Primary Modification: Vice CNO
- 12. Principal Function Performed in Modifying D.A.R.: Increased precedence and added COMSECONDFLT as addressee

7-13-62-51

LOG NOTES AND COMMENTS

MESSAGE 16

Unfiled JCS-Approved Transmission: Reference JBS Log

1. 04 1130Z JBS directed Msg. Ctr. to send CT 1321 to CINCLANT and CINCARIB.
2. 04 1445 JBS directed Msg. Ctr. to increase precedence of CT 1321 and added COMSECONDFLT as addressee.
3. CT 1321 dated 3 June 2100, received 04 1348Z reports disorder in northwest DR and suggests high-altitude recon to see what was going on. Msg. sent as info copy to SecDef and Services. Log notes at 1410 this msg. was discussed with Duty Officer, NFP, who said he would discuss it with Vice CNO. After NFP D/O called back, precedence was revised at 04 1445.
4. 4 June 1530 Special Ass't to CJCS requested copies of CT 1318 and CT 1321 for CJCS about 1700.
5. 4 June 1622 Aide from Chairman's Office was given above msgs. for CJCS.

JOINT STAFF ACTIONS

- A. Action Reference (Msg. Order No.) Message 17
1. Type Action: JCS Message
 2. Action Subject: Orders CINCLANT to position one DD just over horizon off Ciudad Trujillo
 3. Time J/S Action Culminated: 05 1609
- B. Action Requirement Generation
1. Basic Cause: Uncertain
 2. Time of Occurrence: Uncertain
 3. Requirement Recognition: Unknown
 4. Recognition Source: Unknown
 5. Time of Recognition: Unknown
 6. Time of Initial Receipt of Requirement Information in J/S: 05 1315
 7. J/S Contact Point: JBS D/O
 8. Hrs: Min. from Time of Cause to Time J/S Informed: Unknown
 9. Hrs: Min. from Time of Cause to Time J/S Action Culminated: Unknown
 10. Hrs: Min. from Time J/S Informed to Time J/S Action Culminated: 2:54
- C. Establishing Requirement in J/S
1. Time Requirement Information Received by Action Group: 05 1315
 2. Time Action Preparation Ordered: 05 1600
 3. Hrs: Min. Used in Establishing Requirement: 2:45
 4. Principal Time-Consuming Function: Unknown
 5. Initial J/S Action Assignment Point: JBS D/O
 6. Principal Coordinating Functions Performed: Verbally informing higher echelons
 7. Lateral Liaison -- Offices Contacted: State Op Ctr.
 8. Higher Echelons Involved in Decision: Vice Dir J/S, Asst SecState, SecDef
 9. Type Decision: Unknown
 10. Prime Factor in Establishing Requirement: State Dept. request

7-13-62-52

Appendix "B"

<u>D. Preparing Draft Action Recommendation (D.A.R.)</u>	Message 17
1. Time Preparation of D.A.R. Begun:	05 1350
2. Time Preparation of D.A.R. Formally Assigned:	Unknown
3. Time D.A.R. Completed for Presentation:	05 1355
4. Hrs: Min. used in Preparing D.A.R.:	0:05
5. Office Preparing D.A.R.:	JBS D/O
6. Office Ordering D.A.R. Preparation:	Unknown
7. Office Supervising Preparation of D.A.R.:	Unknown
8. Type and No. of Personnel Assigned Action:	1 Lt. Col.
9. Principal Functions Performed:	Drafting message
10. Offices Contacted in Detailing the Requirement:	State Op Ctr, CINCLANT Plans
11. Principal Data Source Utilized in Preparing D.A.R.:	Verbal State Dept. instructions
12. Offices Contacted in Lateral Coordination:	State Op Ctr, CINCLANT Plans
13. Products Resulting:	Draft message
<u>E. Modification and Approval of Action Product</u>	
1. Time D.A.R. Submitted for Approval (to Higher Echelon Office)	05 1355
2. Hrs: Min. Between Completion of D.A.R. and Consideration for Approval:	None
3. Time Transmission of Approved Action Product Ordered:	05 1600
4. Time Transmission of Approved Action Product Effected:	05 1609
5. Hrs: Min. Between Completion of D.A.R. and Transmission of Product Effected:	2:14
6. Office Presenting D.A.R. for Approval:	Unknown
7. Method of Presentation of Product for Approval:	Unknown
8. Offices Reviewing and Approving Action Product:	Vice Dir J/S, SecDef
9. Offices Contacted in Coordinating Action Approval:	Unknown
10. Principal Action Office for Modifying D.A.R.:	Unknown
11. Primary Modification:	Unknown
12. Principal Function Performed in Modifying D.A.R.:	Unknown

LOG NOTES AND COMMENTS

MESSAGE 17

1. At 05 1609Z(05 1209 EDT) CINCLANT is ordered to position one destroyer off Ciudad Trujillo just over the horizon. Msg. signed by Vice Dir. J/S for Dir. J/S. Msg. written by J-3 member JBS and submitted at 1205.

2. At 0915 Dir. Ops Center at State informed JBS that State was considering requesting that a ship ("presumably the NORTH-HAMPTON") move in closer to the DR coast. At 0950 Dir. Ops Ctr. called and said that Ass't SecState had approved one DD over the horizon at Ciudad Trujillo. At 0955 JBS informed SecDef of Ass't SecState's "approval". At 1000 CINCLANT Plans Officer called and was informed of State Dept. approval of moving in DD but that LANT should not make the move without JCS instructions.

3. Log shows that above message was given to Message Center at 0955 and was released by Vice Dir. J/S at 1200. No indication found of who Vice Dir. contacted.

4.

5. JBS Log also notes that on 04 1025 Chief Western Hemisphere Branch of ISA called re State meeting to be held on close-in show-of-force. This meeting was to be between Dir. Ops Ctr. and Ass't Sec. for Inter-American Affairs of State - no further info.

JOINT STAFF ACTIONS

A. Action Reference (Msg. Order No.)

Message 18

1. Type Action:
2. Action Subject:
3. Time J/S Action Culminated:

CJCS Exclusive Message
Response to CINCLANT suggestion
of public announcement of U.S.
objectives in D.R.
05 2218

B. Action Requirement Generation

1. Basic Cause:
2. Time of Occurrence:
3. Requirement Recognition:
4. Recognition Source:
5. Time of Recognition:
6. Time of Initial Receipt of
Requirement Information in J/S:
7. J/S Contact Point:
8. Hrs: Min. from Time of Cause
to Time J/S Informed:
9. Hrs: Min. from Time of Cause
to Time J/S Action Culminated:
10. Hrs: Min. from Time J/S Informed
to Time J/S Action Culminated:

CINCLANT suggestion (above)

Indefinite
Telegram
CINCLANT
03 1730 (D.T.G. of CINCLANT's
message)
03 1858
CJCS
1:28 (From recognition)
52:48 (From recognition)
51:20

C. Establishing Requirement in J/S

1. Time Requirement Information
Received by Action Group:
2. Time Action Preparation Ordered:
3. Hrs: Min. Used in Establishing
Requirement:
4. Principal Time-Consuming Function:

5. Initial J/S Action Assignment
Point:
6. Principal Coordinating Functions
Performed:
7. Lateral Liaison -- Offices
Contacted:
8. Higher Echelons Involved in
Decision:
9. Type Decision:
10. Prime Factor in Establishing
Requirement:

Unknown
Unknown
Unknown
Unknown

Dir J/S
Unknown
Unknown
CJCS
Unknown
Response to a request.

D. Preparing Draft Action Recommendation (D.A.R.)

Message 18

- | | |
|---|-----------------------|
| 1. Time Preparation of D.A.R. Begun: | Unknown |
| 2. Time Preparation of D.A.R. Formally Assigned: | Unknown |
| 3. Time D.A.R. Completed for Presentation: | Unknown |
| 4. Hrs: Min. used in Preparing D.A.R.: | Unknown |
| 5. Office Preparing D.A.R.: | Dir J/S |
| 6. Office Ordering D.A.R. Preparation: | CJCS |
| 7. Office Supervising Preparation of D.A.R.: | Unknown |
| 8. Type and No. of Personnel Assigned Action: | Unknown |
| 9. Principal Functions Performed: | Unknown |
| 10. Offices Contacted in Detailing the Requirement: | Unknown |
| 11. Principal Data Source Utilized in Preparing D.A.R.: | Unknown |
| 12. Offices Contacted in Lateral Coordination: | Exec. Secretary JCS |
| 13. Products Resulting: | JCS Exclusive Message |

E. Modification and Approval of Action Product

- | | |
|---|---------------------|
| 1. Time D.A.R. Submitted for Approval (to Higher Echelon Office) | Unknown |
| 2. Hrs: Min. Between Completion of D.A.R. and Consideration for Approval: | Unknown |
| 3. Time Transmission of Approved Action Product Ordered: | 05 2210 |
| 4. Time Transmission of Approved Action Product Effected: | 05 2218 |
| 5. Hrs: Min. Between Completion of D.A.R. and Transmission of Product Effected: | Unknown |
| 6. Office Presenting D.A.R. for Approval: | Exec. Secretary JCS |
| 7. Method of Presentation of Product for Approval: | Unknown |
| 8. Offices Reviewing and Approving Action Product: | CJCS |
| 9. Offices Contacted in Coordinating Action Approval: | Unknown |
| 10. Principal Action Office for Modifying D.A.R.: | Unknown |
| 11. Primary Modification: | Unknown |
| 12. Principal Function Performed in Modifying D.A.R.: | Unknown |

LOG NOTES AND COMMENTS

MESSAGE 18

1. At 05 2218Z(05 1818 EDT) CJCS sends an "Exclusive for CINCLANT" answering CINCLANT's 03 1730 stating that there has been no further definition of U.S. policy towards the DR situation, that N.Y. Times articles lay satisfactory groundwork for any future government announcements, and that policy of "no comment" remains in force. Msg. drafted by Dir. J/S and signed by Exec. Sec., submitted at 1810.

2. CINCLANT's 03 1730 was an "Exclusive for CJCS" and suggested a government announcement of U.S. objectives in the DR in view of the military moves we had made.

3. At 05 2354Z CINCLANT reminds JCS of planned publicity setup included in [C] and states his "assumption" that handling of commercial press representatives will be through OSD-PA. There is no record of any further liaison on this matter.

JOINT STAFF ACTIONS

A. Action Reference (Mag. Order No.)

Message 19

- 1. Type Action:
- 2. Action Subject:
- 3. Time J/S Action Culminated:

JCS Message
 CINCLANT & SAC told to coordinate
 base support needs directly,
 Ramey and Homestead to be used
 by LANT if needed, []

06 1452

B. Action Requirement Generation

- 1. Basic Cause:
- 2. Time of Occurrence:
- 3. Requirement Recognition:
- 4. Recognition Source:
- 5. Time of Recognition:
- 6. Time of Initial Receipt of Requirement Information in J/S:
- 7. J/S Contact Point:
- 8. Hrs: Min. from Time of Cause to Time J/S Informed:
- 9. Hrs: Min. from Time of Cause to Time J/S Action Culminated:
- 10. Hrs: Min. from Time J/S Informed to Time J/S Action Culminated:

LANT's desire to stage through
 Ramey interferes with SAC oper-
 ations and mission
 02 ~1900

CINCLANT Planning Session

CINCLANT Message to JCS

02 2153

02 2222

JBS D/O

~3:22

~92 hours

88:30

C. Establishing Requirement in J/S

- 1. Time Requirement Information Received by Action Group:
- 2. Time Action Preparation Ordered:
- 3. Hrs: Min. Used in Establishing Requirement:
- 4. Principal Time-Consuming Function:
- 5. Initial J/S Action Assignment Point:
- 6. Principal Coordinating Functions Performed:
- 7. Lateral Liaison -- Offices Contacted:
- 8. Higher Echelons Involved in Decision:
- 9. Type Decision:
- 10. Prime Factor in Establishing Requirement:

03 0426

06 ~1400

~87:38

Attempting to get SAC and LANT
 to work out arrangements
 informally
 JBS D/O

Relay of SAC and LANT informa-
 tion to each other
 AFCEP, SAC Hq, CINCLANT

Unknown -- possibly JCS

Unknown -- probably JCS and
 Ops Dep meeting

Apparent need for JCS order
 rather than informal arrangements

7-13-62-56

D. Preparing Draft Action Recommendation (D.A.R.)

Message 19

- | | |
|---|--|
| 1. Time Preparation of D.A.R. Begun: | 03 0426 |
| 2. Time Preparation of D.A.R. Formally Assigned: | 06 1400 |
| 3. Time D.A.R. Completed for Presentation: | Unknown |
| 4. Hrs: Min. used in Preparing D.A.R.: | Unknown |
| 5. Office Preparing D.A.R.: | Chief Implementation Div.
Ofc. of the Sec, JCS
Probably JCS & Ops Deps |
| 6. Office Ordering D.A.R. Preparation: | Unknown |
| 7. Office Supervising Preparation of D.A.R.: | Unknown |
| 8. Type and No. of Personnel Assigned Action: | Unknown |
| 9. Principal Functions Performed: | Unknown |
| 10. Offices Contacted in Detailing the Requirement: | Unknown |
| 11. Principal Data Source Utilized in Preparing D.A.R.: | Unknown |
| 12. Offices Contacted in Lateral Coordination: | Unknown |
| 13. Products Resulting: | Unknown |

E. Modification and Approval of Action Product

- | | |
|---|-----------------------------------|
| 1. Time D.A.R. Submitted for Approval (to Higher Echelon Office) | Unknown |
| 2. Hrs: Min. Between Completion of D.A.R. and Consideration for Approval: | Unknown |
| 3. Time Transmission of Approved Action Product Ordered: | 06 1436 |
| 4. Time Transmission of Approved Action Product Effected: | 06 1452 |
| 5. Hrs: Min. Between Completion of D.A.R. and Transmission of Product Effected: | Unknown |
| 6. Office Presenting D.A.R. for Approval: | Unknown |
| 7. Method of Presentation of Product for Approval: | Probably JCS & Ops Deps Meetings. |
| 8. Offices Reviewing and Approving Action Product: | Unknown |
| 9. Offices Contacted in Coordinating Action Approval: | Unknown |
| 10. Principal Action Office for Modifying D.A.R.: | Unknown |
| 11. Primary Modification: | Unknown |
| 12. Principal Function Performed in Modifying D.A.R.: | Unknown |

LOG NOTES AND COMMENTS

MESSAGE 19

1. At 06 1452Z(06 1052 EDT) CINCLANT and CINCSAC were told to coordinate their base support needs directly. LANT's 02 2153 and SAC's 03 1026 were referenced. CINCLANT was authorized to determine base support priorities for Ramey and Homestead AFB's if [] was implemented. []

] Msg.

released by USMC L/C, Chief, Implementation Division, submitted at 1036. Writer not noted.

2. LANT's 02 2153 to JCS requests permission to stage a Marine attack squadron through Ramey. At 03 0030(log time) msg. was passed to AFCP and SAC with request for their recommendation by 1000. SAC's 03 1026 to CINCLANT says they can handle, but there may be conflict with planned TAC operations, discusses USAF support for A4D's, and requests LANT mobile maintenance team.

3. By message of 03 1638Z LANT requested JCS to answer their 02 2153. JBS log notes "Action Pending".

4. On 03 at 0210(log time) USAF D/O called JBS and stated that SAC had LANT's request for staging through Ramey but there was no SAC answer yet. On 05 at 0300(log time) AFCP called requesting forewarning in the future and complaining about Navy personnel being received unannounced at Ramey. CINCLANT D/O was informed of the AFCP call.

5. On 5 June there was a JCS meeting at 1330; on 6 June at 1000 an Ops Deps. meeting. (Probably decisions reflected in this message were formulated at these two meetings.)

JOINT STAFF ACTIONS

A. Action Reference (Msg. Order No.)

Message 20

- | | |
|--------------------------------|--|
| 1. Type Action: | CJCS Message Exclusive for CINCLANT |
| 2. Action Subject: | National situation report - OAS team
Venezuelan forces, and State Dept
actions |
| 3. Time J/S Action Culminated: | 6 June |

B. Action Requirement Generation

- | | |
|--|---|
| 1. Basic Cause: | Planned meeting with President
would have been of interest to
CINCLANT - meeting cancelled. |
| 2. Time of Occurrence: | 06 1500 |
| 3. Requirement Recognition: | CJCS generated -- no data available |
| 4. Recognition Source: | " " |
| 5. Time of Recognition: | " " |
| 6. Time of Initial Receipt of
Requirement Information in J/S: | " " |
| 7. J/S Contact Point: | CJCS |
| 8. Hrs: Min. from Time of Cause
to Time J/S Informed: | Unknown |
| 9. Hrs: Min. from Time of Cause
to Time J/S Action Culminated: | Unknown |
| 10. Hrs: Min. from Time J/S Informed
to Time J/S Action Culminated: | Unknown |

C. Establishing Requirement in J/S

- | | |
|--|---|
| 1. Time Requirement Information
Received by Action Group: | Unknown |
| 2. Time Action Preparation Ordered: | Unknown |
| 3. Hrs: Min. Used in Establishing
Requirement: | Unknown |
| 4. Principal Time-Consuming Function: | Unknown |
| 5. Initial J/S Action Assignment
Point: | Unknown |
| 6. Principal Coordinating Functions
Performed: | Unknown |
| 7. Lateral Liaison -- Offices
Contacted: | Unknown |
| 8. Higher Echelons Involved in
Decision: | Unknown |
| 9. Type Decision: | Personal CJCS |
| 10. Prime Factor in Establishing
Requirement: | Desire to keep CINCLANT informed
of National level view of
situation. |

D. Preparing Draft Action Recommendation (D.A.R.)

Message 20

- | | |
|---|---------|
| 1. Time Preparation of D.A.R. Begun: | Unknown |
| 2. Time Preparation of D.A.R. Formally Assigned: | Unknown |
| 3. Time D.A.R. Completed for Presentation: | Unknown |
| 4. Hrs: Min. used in Preparing D.A.R.: | Unknown |
| 5. Office Preparing D.A.R.: | Unknown |
| 6. Office Ordering D.A.R. Preparation: | CJCS |
| 7. Office Supervising Preparation of D.A.R.: | Unknown |
| 8. Type and No. of Personnel Assigned Action: | Unknown |
| 9. Principal Functions Performed: | Unknown |
| 10. Offices Contacted in Detailing the Requirement: | Unknown |
| 11. Principal Data Source Utilized in Preparing D.A.R.: | Unknown |
| 12. Offices Contacted in Lateral Coordination: | Unknown |
| 13. Products Resulting: | Unknown |

E. Modification and Approval of Action Product

- | | |
|---|---------|
| 1. Time D.A.R. Submitted for Approval (to Higher Echelon Office) | Unknown |
| 2. Hrs: Min. Between Completion of D.A.R. and Consideration for Approval: | Unknown |
| 3. Time Transmission of Approved Action Product Ordered: | Unknown |
| 4. Time Transmission of Approved Action Product Effected: | Unknown |
| 5. Hrs: Min. Between Completion of D.A.R. and Transmission of Product Effected: | Unknown |
| 6. Office Presenting D.A.R. for Approval: | Unknown |
| 7. Method of Presentation of Product for Approval: | Unknown |
| 8. Offices Reviewing and Approving Action Product: | CJCS |
| 9. Offices Contacted in Coordinating Action Approval: | Unknown |
| 10. Principal Action Office for Modifying D.A.R.: | Unknown |
| 11. Primary Modification: | Unknown |
| 12. Principal Function Performed in Modifying D.A.R.: | Unknown |

7-13-62-59

Appendix "B"

~~TOP SECRET~~

LOG NOTES AND COMMENTS

MESSAGE 20

1. On 6 June CJCS sends an "Exclusive for CINCLANT". Informs him that noon meeting with President cancelled. SecState-DR Consul-Chief Ops Center State conference indicates DR situation is quiet, OAS team leaves 07 1000Q. Pres. Venezuela objects to landings, no action imminent, and replacement named for DR Consul.

2. Formal copy not available - no times or personnel involved recorded - no mention in log, other than bond copy received and filed.

3. (Message appears to be an effort by CJCS on his own initiative to keep his commander informed of the local situation - a followup of his 05 2218 "Exclusive for CINCLANT".)

4. 6 June 0930: Vice Dir. J/S directed JBS to prepare briefing book for CJCS for 1130 meeting with President.

JOINT STAFF ACTIONS

A. Action Reference (Msg. Order No.)

Message 21

1. Type Action:
2. Action Subject:
3. Time J/S Action Culminated:

JCS Message

CINCLANT ordered to plan for 3 different initiating conditions and his preference requested. 06 2125

B. Action Requirement Generation

1. Basic Cause:
2. Time of Occurrence:
3. Requirement Recognition:
4. Recognition Source:
5. Time of Recognition:
6. Time of Initial Receipt of Requirement Information in J/S:
7. J/S Contact Point:
8. Hrs: Min. from Time of Cause to Time J/S Informed:
9. Hrs: Min. from Time of Cause to Time J/S Action Culminated:
10. Hrs: Min. from Time J/S Informed to Time J/S Action Culminated:

Planning problems caused by unknown degree of force to be employed.

03 ~1900

LANT Planning Meetings

CINCLANT Message

05 2212

06 0042

JBS D/O

53:42

74:25

20:43

C. Establishing Requirement in J/S

1. Time Requirement Information Received by Action Group:
2. Time Action Preparation Ordered:
3. Hrs: Min. Used in Establishing Requirement:
4. Principal Time-Consuming Function:
5. Initial J/S Action Assignment Point:
6. Principal Coordinating Functions Performed:
7. Lateral Liaison -- Offices Contacted:
8. Higher Echelons Involved in Decision:
9. Type Decision:
10. Prime Factor in Establishing Requirement:

06 0757

06 1300

12:18

Waiting for Generals to get to work in the morning.

J-3 D/O JBS

Alerting Dep Dir J-3

Unknown

Dep Dir J-3, Dir J/S

Personal Dir J/S

CINCLANT request

7-13-62-60

Appendix "B"

D. Preparing Draft Action Recommendation (D.A.R.)

Message 21

- 1. Time Preparation of D.A.R. Begun: Unknown Received 06 0757
- 2. Time Preparation of D.A.R. Formally Assigned: 06 1300
- 3. Time D.A.R. Completed for Presentation: Unknown
- 4. Hrs: Min. used in Preparing D.A.R.: Unknown
- 5. Office Preparing D.A.R.: J-3 Member JBS
- 6. Office Ordering D.A.R. Preparation: Dir J-3
- 7. Office Supervising Preparation of D.A.R.: Dep Dir J-3
- 8. Type and No. of Personnel Assigned Action: 1 Lt. Col.
- 9. Principal Functions Performed: Procurement of alternatives for planning
- 10. Offices Contacted in Detailing the Requirement: Unknown
- 11. Principal Data Source Utilized in Preparing D.A.R.: Unknown
- 12. Offices Contacted in Lateral Coordination: Unknown
- 13. Products Resulting: JCS Message

E. Modification and Approval of Action Product

- 1. Time D.A.R. Submitted for Approval (to Higher Echelon Office) Unknown
- 2. Hrs: Min. Between Completion of D.A.R. and Consideration for Approval: Unknown
- 3. Time Transmission of Approved Action Product Ordered: 06 2110
- 4. Time Transmission of Approved Action Product Effected: 06 2125
- 5. Hrs: Min. Between Completion of D.A.R. and Transmission of Product Effected: Unknown
- 6. Office Presenting D.A.R. for Approval: J-3 Member JBS
- 7. Method of Presentation of Product for Approval: Unknown
- 8. Offices Reviewing and Approving Action Product: Vice Dir J/S and Dir J/S
- 9. Offices Contacted in Coordinating Action Approval: Unknown
- 10. Principal Action Office for Modifying D.A.R.: Unknown
- 11. Primary Modification: Unknown
- 12. Principal Function Performed in Modifying D.A.R.: Unknown

7-13-62-61

Appendix "B"

LOG NOTES AND COMMENTS

MESSAGE 21

1. At 06 2125Z(06 1725 EDT) CINCLANT is requested to plan for three ways in which actions might be initiated and provide comments as to his preferences (for use in "discussions with other government agencies"). Alternatives concern ultimatum, limited preassault preparatory attacks, and full-scale pre-assault preparatory attacks. He is also informed that the degree of force to be employed will be decided in light of political objectives at time intervention is decided upon. LANT's 05 2212 is referenced.

2. Msg. written by J-3 member JBS, signed by Dep. Dir. J/S, addressed as Dir. J/S sends, and submitted at 1710.

3. LANT's 05 2212 to JCS reports status of planning for augmented forces, and requests JCS guidance as to the degree of force to be employed. JBS D/O notes on receipt of msg. "to be brought to attention of J-3 in morning".

4. At 06 0900(log time) Dir. JBS advised JBS that Dir. J/S wants msg. sent to CINCLANT advising on current guidance re pre-D-hour air assault.

5. At 05 1330 two J-3 members of JBS briefed JCS in detail on plans for use of augmented force.

6. The alternatives given to CINCLANT for planning were developed in the initial LANT Planning Conference at Norfolk on 3 June, attended by the J-3 members of JBS.

JOINT STAFF ACTIONS

A. Action Reference (Msg. Order No.)

Message 22

- 1. Type Action:
- 2. Action Subject:
- 3. Time J/S Action Culminated:

JCS Message
 CINCLANT & CARIB informed that policy for use of Latin American Forces is not firm.
 08 0017

B. Action Requirement Generation

- 1. Basic Cause:
- 2. Time of Occurrence:
- 3. Requirement Recognition:
- 4. Recognition Source:
- 5. Time of Recognition:
- 6. Time of Initial Receipt of Requirement Information in J/S:
- 7. J/S Contact Point:
- 8. Hrs: Min. from Time of Cause to Time J/S Informed:
- 9. Hrs: Min. from Time of Cause to Time J/S Action Culminated:
- 10. Hrs: Min. from Time J/S Informed to Time J/S Action Culminated:

LANT had been informed that at least Venezuelan Forces would be available and suggested coordination with his Forces.
 04 0000 (Caracas Message to LANT)
 CINCLANT Staff Discussion
 CINCLANT
 05 2030 (LANT request to JCS)
 05 2309
 Probably JBS D/O
 ~47 hours
 ~96 hours
 ~49 hours

C. Establishing Requirement in J/S

- 1. Time Requirement Information Received by Action Group:
- 2. Time Action Preparation Ordered:
- 3. Hrs: Min. Used in Establishing Requirement:
- 4. Principal Time-Consuming Function:
- 5. Initial J/S Action Assignment Point:
- 6. Principal Coordinating Functions Performed:
- 7. Lateral Liaison -- Offices Contacted:
- 8. Higher Echelons Involved in Decision:
- 9. Type Decision:
- 10. Prime Factor in Establishing Requirement:

05 2309
 After 07 1200
 More than 37 hours
 No records -- Unknown
 " "
 " "
 " "
 " "
 " "
 " "
 Request from CINCARIB to participate in discussions with Latin American countries

~~TOP SECRET~~

D. Preparing Draft Action Recommendation (D.A.R.)

Message 22

- 1. Time Preparation of D.A.R. Begun: Unknown
- 2. Time Preparation of D.A.R. Formally Assigned: After 07 1200
- 3. Time D.A.R. Completed for Presentation: Unknown
- 4. Hrs: Min. used in Preparing D.A.R.: Unknown
- 5. Office Preparing D.A.R.: J-3 Member JBS
- 6. Office Ordering D.A.R. Preparation: Vice Dir J/S
- 7. Office Supervising Preparation of D.A.R.: Dep Dir J-3
- 8. Type and No. of Personnel Assigned Action: 1 Lt. Col.
- 9. Principal Functions Performed: Unknown
- 10. Offices Contacted in Detailing the Requirement: Unknown
- 11. Principal Data Source Utilized in Preparing D.A.R.: Unknown
- 12. Offices Contacted in Lateral Coordination: Unknown
- 13. Products Resulting: JCS Message Draft

E. Modification and Approval of Action Product

- 1. Time D.A.R. Submitted for Approval (to Higher Echelon Office) Unknown
- 2. Hrs: Min. Between Completion of D.A.R. and Consideration for Approval: Unknown
- 3. Time Transmission of Approved Action Product Ordered: 07 2340
- 4. Time Transmission of Approved Action Product Effected: 08 0017
- 5. Hrs: Min. Between Completion of D.A.R. and Transmission of Product Effected: 0:37
- 6. Office Presenting D.A.R. for Approval: Unknown
- 7. Method of Presentation of Product for Approval: Unknown
- 8. Offices Reviewing and Approving Action Product: Dir & Vice Dir J/S
- 9. Offices Contacted in Coordinating Action Approval: Unknown
- 10. Principal Action Office for Modifying D.A.R.: Unknown
- 11. Primary Modification: Unknown
- 12. Principal Function Performed in Modifying D.A.R.: Unknown

7-13-62-63

~~TOP SECRET~~

~~TOP SECRET~~

LOG NOTES AND COMMENTS

MESSAGE 22

1. At 08 0017Z(07 2017 EDT) CINCLANT and CINCARIB are informed that U.S. policy is not firm enough to provide guidance for support by Latin American forces, and LANT's 05 2030 and CARIB's 06 1927 recommendations (for approach to Venezuelan military and direct coordination) are under consideration.

2. Msg. drafted by J-3 member JBS, signed by Vice Dir. J/S for Dir. J/S, addressed as Dir. J/S sends, and submitted at 1940.

3. CINCLANT's 05 2030 requests guidance as to employment of Latin-American forces, suggests contact arranged through JCS with LANT representation, suggests attempting to make Latin-American forces subordinate to JTF-122 Cdr. and suggests they provide military liaison officers with the JTF. State's 03, PM msg. from Caracas is referenced.

4. This State msg. was addressed to POLAD/CINCARIB for info, and a note on JBS file copy says "copy sent to CINCLANT". Msg. reports results of meeting of Pres. Venezuela with his military chiefs-of-staff, []

5. CINCARIB's 06 1927 requests representation in any meeting of LANT's representative with Latin-American countries. Note on msg. says Dep. Dir. J-3 and J-3 member JBS informed 06 2100 - "hold until morning".

6. On 7 June at 1830(log time) CJCS was debriefed re meeting at White House. Log says "no JBS action". Two additional briefing books had been prepared by JBS for this meeting.

7. At 07 1610(log time) JBS was informed by AFCP that airplane with OAS Observer Team was on the ground at Ciudad Trujillo.

8. There are no records of consideration of LANT's proposal in the Joint Staff. (What Vice Dir. and/or Dir. J/S meant in msg. is unknown. There is no indicated followup by either LANT or the Joint Staff.)

~~TOP SECRET~~

JOINT STAFF ACTIONS

A. Action Reference (Mag. Order No.)

Message 23

1. Type Action:
2. Action Subject:
3. Time J/S Action Culminated:

JCS Message
CINCLANT informed that MPSA is setting up POL reserve per LANT request
08 2010

B. Action Requirement Generation

1. Basic Cause:
2. Time of Occurrence:
3. Requirement Recognition:
4. Recognition Source:
5. Time of Recognition:
6. Time of Initial Receipt of Requirement Information in J/S:
7. J/S Contact Point:
8. Hrs: Min. from Time of Cause to Time J/S Informed:
9. Hrs: Min. from Time of Cause to Time J/S Action Culminated:
10. Hrs: Min. from Time J/S Informed to Time J/S Action Culminated:

LANT's concern with resupply problems
07~1400
Probably CINCLANT Planning Conference
LANT Message
07 1538
07 1650
Apparently J-4
2:50
~30 hours
27:20

C. Establishing Requirement in J/S

1. Time Requirement Information Received by Action Group:
2. Time Action Preparation Ordered:
3. Hrs: Min. Used in Establishing Requirement:
4. Principal Time-Consuming Function:
5. Initial J/S Action Assignment Point:
6. Principal Coordinating Functions Performed:
7. Lateral Liaison -- Offices Contacted:
8. Higher Echelons Involved in Decision:
9. Type Decision:
10. Prime Factor in Establishing Requirement:

Unknown
Unknown
Unknown
Unknown
J-4
Unknown
MEPA
Unknown
Unknown
Clear-cut request for J-4 assistance

7-13-62-64

Appendix "B"

~~TOP SECRET~~

D. Preparing Draft Action Recommendation (D.A.R.)

- | | |
|---|-------------------------------------|
| 1. Time Preparation of D.A.R. Begun: | Unknown |
| 2. Time Preparation of D.A.R. Formally Assigned: | Unknown |
| 3. Time D.A.R. Completed for Presentation: | Unknown |
| 4. Hrs: Min. used in Preparing D.A.R.: | Unknown |
| 5. Office Preparing D.A.R.: | Petroleum Branch, R & C Div.
J-4 |
| 6. Office Ordering D.A.R. Preparation: | Unknown |
| 7. Office Supervising Preparation of D.A.R.: | Unknown |
| 8. Type and No. of Personnel Assigned Action: | Unknown |
| 9. Principal Functions Performed: | Coordination with MPSA |
| 10. Offices Contacted in Detailing the Requirement: | MPSA |
| 11. Principal Data Source Utilized in Preparing D.A.R.: | Unknown |
| 12. Offices Contacted in Lateral Coordination: | Unknown |
| 13. Products Resulting: | J-4 Message |

E. Modification and Approval of Action Product

- | | |
|---|---------|
| 1. Time D.A.R. Submitted for Approval (to Higher Echelon Office) | Unknown |
| 2. Hrs: Min. Between Completion of D.A.R. and Consideration for Approval: | Unknown |
| 3. Time Transmission of Approved Action Product Ordered: | 08 1945 |
| 4. Time Transmission of Approved Action Product Effected: | 08 2010 |
| 5. Hrs: Min. Between Completion of D.A.R. and Transmission of Product Effected: | Unknown |
| 6. Office Presenting D.A.R. for Approval: | Unknown |
| 7. Method of Presentation of Product for Approval: | Unknown |
| 8. Offices Reviewing and Approving Action Product: | J-4 |
| 9. Offices Contacted in Coordinating Action Approval: | Unknown |
| 10. Principal Action Office for Modifying D.A.R.: | Unknown |
| 11. Primary Modification: | Unknown |
| 12. Principal Function Performed in Modifying D.A.R.: | Unknown |

LOG NOTES AND COMMENTS

MESSAGE 23

1. At 08 2010Z(08 1610 EDT) CINCLANT is informed that MPSA is setting up POL cargo for reserve and resupply of Ramey, per LANT's request in LANT's 07 1538.

2. Msg. written by Petroleum Branch, R&C Div., J-4, signed by "Secretary" (J-4), submitted at 1545Z and addressed as J-4 sends. Info copies to MPSA, COMSTS, Services and commands concerned.

3. LANT's 07 1538 was received 07 1650Z, to JCS, info MPSA, COMSTS, Services and same commands as for above JCS msg. LANT recommends a tailored T-2 load of Av fuels available for general backing. This msg. is cancelled by LANT's 14 2312.

4. No record of LANT's 07 1538 in log and copy filed was received JWR 15 June.

5. On 03 1938 LANT asked JCS to arrange to remove POL import quota for Puerto Rico in case [] becomes operational. This was answered by MPSA's 07 1726 that arrangements had been made for quota as necessary. Action had been assigned to J-4 at 2100 R.

~~TOP SECRET~~

JOINT STAFF ACTIONS

A. Action Reference (Msg. Order No.)

Message 24

- | | |
|--------------------------------|--|
| 1. Type Action: | JCS Message |
| 2. Action Subject: | CINCLANT ordered to reduce readiness of Forces and plan for OPLAN exercise |
| 3. Time J/S Action Culminated: | 09 2314 |

B. Action Requirement Generation

- | | |
|---|--|
| 1. Basic Cause: | Decision that D/R Gov't will be satisfactory to U.S. |
| 2. Time of Occurrence: | 09~1600 |
| 3. Requirement Recognition: | State-Defense Meeting |
| 4. Recognition Source: | JCS representatives at meeting |
| 5. Time of Recognition: | 09~1600 |
| 6. Time of Initial Receipt of Requirement Information in J/S: | 09~1700 |
| 7. J/S Contact Point: | JBS and JCS |
| 8. Hrs: Min. from Time of Cause to Time J/S Informed: | 1 hour |
| 9. Hrs: Min. from Time of Cause to Time J/S Action Culminated: | ~7:14 |
| 10. Hrs: Min. from Time J/S Informed to Time J/S Action Culminated: | ~6:14 |

C. Establishing Requirement in J/S

- | | |
|---|---|
| 1. Time Requirement Information Received by Action Group: | 09~1700 |
| 2. Time Action Preparation Ordered: | 09 1900 |
| 3. Hrs: Min. Used in Establishing Requirement: | ~2:00 |
| 4. Principal Time-Consuming Function: | Consideration of subject of Message |
| 5. Initial J/S Action Assignment Point: | Vice Dir J/S |
| 6. Principal Coordinating Functions Performed: | Unknown |
| 7. Lateral Liaison -- Offices Contacted: | Unknown |
| 8. Higher Echelons Involved in Decision: | Unknown |
| 9. Type Decision: | Unknown |
| 10. Prime Factor in Establishing Requirement: | Apparently ordered at State-Defense Meeting |

7-13-62-66

Appendix "B"

~~TOP SECRET~~

D. Preparing Draft Action Recommendation (D.A.R.)

Message 24

- | | |
|---|---|
| 1. Time Preparation of D.A.R. Begun: | 09 1900 |
| 2. Time Preparation of D.A.R. Formally Assigned: | 09 1900 |
| 3. Time D.A.R. Completed for Presentation: | 09 2130 |
| 4. Hrs: Min. used in Preparing D.A.R.: | 2:30 |
| 5. Office Preparing D.A.R.: | JBS |
| 6. Office Ordering D.A.R. Preparation: | Vice Dir J/S |
| 7. Office Supervising Preparation of D.A.R.: | Probably Dep Dir J-3 |
| 8. Type and No. of Personnel Assigned Action: | Unknown |
| 9. Principal Functions Performed: | Drafting request for LANT recommendation for reducing readiness of CINCLANT Staff of Forces |
| 10. Offices Contacted in Detailing the Requirement: | |
| 11. Principal Data Source Utilized in Preparing D.A.R.: | Verbal Dep Dir J/S |
| 12. Offices Contacted in Lateral Coordination: | Unknown |
| 13. Products Resulting: | Draft Message |

E. Modification and Approval of Action Product

- | | |
|---|--|
| 1. Time D.A.R. Submitted for Approval (to Higher Echelon Office) | 09 2130 |
| 2. Hrs: Min. Between Completion of D.A.R. and Consideration for Approval: | 0:00 |
| 3. Time Transmission of Approved Action Product Ordered: | 09 2300 |
| 4. Time Transmission of Approved Action Product Effected: | 09 2314 |
| 5. Hrs: Min. Between Completion of D.A.R. and Transmission of Product Effected: | 1:44 |
| 6. Office Presenting D.A.R. for Approval: | Vice Dir J/S |
| 7. Method of Presentation of Product for Approval: | Personal Review |
| 8. Offices Reviewing and Approving Action Product: | CJCS, SecDef, SecState |
| 9. Offices Contacted in Coordinating Action Approval: | CINCLANT Staff |
| 10. Principal Action Office for Modifying D.A.R.: | J-3 |
| 11. Primary Modification: | CJCS and SecDef |
| 12. Principal Function Performed in Modifying D.A.R.: | Revised message purpose from request for LANT's recommendations to a direct order to reduce readiness. |

7-13-62-67

Appendix "B"

LOG NOTES AND COMMENTS

MESSAGE 24

1. At 09 2314Z(09 1914 EDT) CINCLANT is informed that immediate execution of DR OPLAN will not be required. He is ordered to decrease readiness for all but a small amphibious force in the DR area and to include this consideration in planning for test exercise of OPLAN.

2. Msg. written by "J-3", signed by Adm. Assistant to CJCS, addressed from CJCS and submitted at 1900. Note on msg. says: "Cleared by SecDef and State (Mr. Johnson)."

3. DR Log notes following preparatory actions, 8 and 9 June: talking paper for State-JCS meeting prepared by JBS.

4. 09 1130 State-JCS meeting. J-3 member of JBS attended. Decision that State "is prepared to see military operations in support of DR unwind" but everything should not be withdrawn at once. CNO stated that we would like to hold an exercise prior to withdrawing forces.

5. 09 1230 call to CINCLANT Staff advised LANT msg. in preparation recommending exercise to JCS.

6. 09 1500 Vice Dir. J/S directed preparation of a message requesting LANT's recommendation for reducing readiness.

7. "Msg. was prepared in draft and delivered": 09 1730 Vice Dir. J/S advised that CJCS was going to take up substance of msg. with SecDef, "Msg. had been changed directing the reducing of readiness posture".

8. 09 1900 "Msg. approved by JCS transmitted to CINCLANT".

~~TOP SECRET~~

JOINT STAFF ACTIONS

A. Action Reference (Msg. Order No.)

Message 25

- | | |
|--------------------------------|--|
| 1. Type Action: | JCS Message |
| 2. Action Subject: | CINCLANT given preliminary favorable reaction to request for Exercise and ordered to present more details. |
| 3. Time J/S Action Culminated: | 10 1811 |

B. Action Requirement Generation

- | | |
|---|---|
| 1. Basic Cause: | Decision not to use Forces assembled for D/R made exercise cheap. |
| 2. Time of Occurrence: | 07~0000 |
| 3. Requirement Recognition: | Unknown |
| 4. Recognition Source: | COMSECONDFLT |
| 5. Time of Recognition: | 07 0237 |
| 6. Time of Initial Receipt of Requirement Information in J/S: | 09 2049 |
| 7. J/S Contact Point: | JBS D/O |
| 8. Hrs: Min. from Time of Cause to Time J/S Informed: | ~69 hours |
| 9. Hrs: Min. from Time of Cause to Time J/S Action Culminated: | ~90 hours |
| 10. Hrs: Min. from Time J/S Informed to Time J/S Action Culminated: | 21:22 |

C. Establishing Requirement in J/S

- | | |
|---|--------------------------------------|
| 1. Time Requirement Information Received by Action Group: | 09~2100 |
| 2. Time Action Preparation Ordered: | Unknown |
| 3. Hrs: Min. Used in Establishing Requirement: | Unknown |
| 4. Principal Time-Consuming Function: | Unknown |
| 5. Initial J/S Action Assignment Point: | JBS |
| 6. Principal Coordinating Functions Performed: | Collecting information from Services |
| 7. Lateral Liaison -- Offices Contacted: | COMSECONDFLT, CNO, CGUSCONARC, TAC |
| 8. Higher Echelons Involved in Decision: | Vice Dir J/S |
| 9. Type Decision: | Unknown |
| 10. Prime Factor in Establishing Requirement: | Specific LANT request merits answer. |

7-13-62-68

~~TOP SECRET~~

TOP SECRET

D. Preparing Draft Action Recommendation (D.A.R.)

Message 25

- 1. Time Preparation of D.A.R. Begun: Unknown
- 2. Time Preparation of D.A.R. Formally Assigned: Unknown
- 3. Time D.A.R. Completed for Presentation: Unknown
- 4. Hrs: Min. used in Preparing D.A.R.: Unknown
- 5. Office Preparing D.A.R.: Vice Dir J/S
- 6. Office Ordering D.A.R. Preparation: Dir J/S
- 7. Office Supervising Preparation of D.A.R.: Unknown
- 8. Type and No. of Personnel Assigned Action: Unknown
- 9. Principal Functions Performed: Unknown
- 10. Offices Contacted in Detailing the Requirement: CNO, CJCS
- 11. Principal Data Source Utilized in Preparing D.A.R.: Unknown
- 12. Offices Contacted in Lateral Coordination: Unknown
- 13. Products Resulting: Draft Message

E. Modification and Approval of Action Product

- 1. Time D.A.R. Submitted for Approval (to Higher Echelon Office) Unknown
- 2. Hrs: Min. Between Completion of D.A.R. and Consideration for Approval: Unknown
- 3. Time Transmission of Approved Action Product Ordered: 10 1640
- 4. Time Transmission of Approved Action Product Effected: 10 1811
- 5. Hrs: Min. Between Completion of D.A.R. and Transmission of Product Effected: Unknown
- 6. Office Presenting D.A.R. for Approval: Vice Dir J/S
- 7. Method of Presentation of Product for Approval: Unknown
- 8. Offices Reviewing and Approving Action Product: CJCS, Dir J/S
- 9. Offices Contacted in Coordinating Action Approval: SecDef
- 10. Principal Action Office for Modifying D.A.R.: Unknown
- 11. Primary Modification: Unknown
- 12. Principal Function Performed in Modifying D.A.R.: Unknown

7-13-62-69

TOP SECRET

LOG NOTES AND COMMENTS

MESSAGE 25

1. At 10 1811Z(10 1411 EDT) CINCLANT is told that preliminary reaction to his proposal for an exercise (LANT's 09 1939) is favorable, that decision will not be made before 12 June, and that direct liaison between COM TAC, CONARC and LANT is authorized for exercise planning. LANT's recommendation is requested for D-Day and designation of units to report to CINCLANT for operational control.

2. Msg. writer not listed, signed by Vice Dir. J/S, addressed as Dir. J/S sends, and submitted at 1340 for priority transmission

3. At 07 0237Z COMSECONDFLT proposed a 2- or 3-day exercise to CINCLANTFLT if Task Fleet's mission is not executed. This msg. was readdressed to CNO on 8 June and received at 09 0204Z. It was rerouted to JCS, State and CSAF at 09 0710.

4. At 08 1857Z CGUSCONARC informed CG US Third Army that CINCLANT was considering testing of OPLAN, passed on the concept of the test and requested comments. This msg. was answered at 08 2200, stating that CG US Third Army had no objection and some desire to conduct test. Both of these msgs. are burn copies, not logged in JWR and apparently were brought in by Army JBS ofcr. The specific msg. from LANT to CONARC is not on file.

5. LANT's 09 1939 to JCS largely repeats COMSECONDFLT's 07037 and adds that CONARC and TAC agree in desirability of exercise. No pertinent TAC liaison msgs. are in file.

6. On 9 June at 1130 State-JCS meeting, CNO stated that he would like to hold an exercise. At 1230(log time) JBS phone call to CINCLANT determined that msg. to JCS was in preparation requesting the exercise. JCS 09 2314 relates exercise to decreased readiness and that CJCS and the SecDef were involved. Log notes that this msg. (JCS 10 1811) was released by Vice Dir. J/S at 1340 and was "cleared by Chairman."

7. JBP SITREP of 0630 10 June announces that exercise is under consideration.

8. On 21 June SAC's 21 2135 to C/S USAF informs of lack of notification of SAC re exercise and requests notification in future to prevent interference with the SAC mission.

TOP SECRET

JOINT STAFF ACTIONS

A. Action Reference (Mag. Order No.)

Message 26

- | | |
|--------------------------------|---|
| 1. Type Action: | JCS Message |
| 2. Action Subject: | Funding of exercise to be handled through individual Services |
| 3. Time J/S Action Culminated: | 13 2132 |

B. Action Requirement Generation

- | | |
|---|---|
| 1. Basic Cause: | CONARC and TAC informed CINCLANT of need for additional training funds. |
| 2. Time of Occurrence: | Probably 11 June |
| 3. Requirement Recognition: | Telegrams |
| 4. Recognition Source: | CINCLANT |
| 5. Time of Recognition: | Probably 11 June |
| 6. Time of Initial Receipt of Requirement Information in J/S: | Probably phone conversation CINCLANT with CJCS ~ 12 1400 |
| 7. J/S Contact Point: | CJCS |
| 8. Hrs: Min. from Time of Cause to Time J/S Informed: | ~26 hours |
| 9. Hrs: Min. from Time of Cause to Time J/S Action Culminated: | ~57:30 |
| 10. Hrs: Min. from Time J/S Informed to Time J/S Action Culminated: | ~31:30 |

C. Establishing Requirement in J/S

- | | |
|---|---|
| 1. Time Requirement Information Received by Action Group: | 12 1500 |
| 2. Time Action Preparation Ordered: | 12 1500 |
| 3. Hrs: Min. Used in Establishing Requirement: | 0:00 |
| 4. Principal Time-Consuming Function: | None |
| 5. Initial J/S Action Assignment Point: | JBS D/O |
| 6. Principal Coordinating Functions Performed: | Determining if Services could bear cost of exercise |
| 7. Lateral Liaison -- Offices Contacted: | AFCP, NFP, AWR, AF Plans, TAC, AF Hq Transport Div. |
| 8. Higher Echelons Involved in Decision: | Vice Dir J/S, CJCS |
| 9. Type Decision: | JCS and Ops Deps Meetings |
| 10. Prime Factor in Establishing Requirement: | Direct LANT request for help. |

7-13-62-70

D. Preparing Draft Action Recommendation (D.A.R.)

Message 26:

- 1. Time Preparation of D.A.R. Begun: Unknown
- 2. Time Preparation of D.A.R. Formally Assigned: Unknown
- 3. Time D.A.R. Completed for Presentation: Unknown
- 4. Hrs: Min. used in Preparing D.A.R.: Unknown
- 5. Office Preparing D.A.R.: J-3, Current Opns. Div.
- 6. Office Ordering D.A.R. Preparation: Vice Dir J/S
- 7. Office Supervising Preparation of D.A.R.: Dep Dir J-3
- 8. Type and No. of Personnel Assigned Action: 1 Col.
- 9. Principal Functions Performed: Unknown
- 10. Offices Contacted in Detailing the Requirement: Unknown
- 11. Principal Data Source Utilized in Preparing D.A.R.: Unknown
- 12. Offices Contacted in Lateral Coordination: Unknown
- 13. Products Resulting: Talking paper and Draft Message

E. Modification and Approval of Action Product

- 1. Time D.A.R. Submitted for Approval (to Higher Echelon Office) Unknown
- 2. Hrs: Min. Between Completion of D.A.R. and Consideration for Approval: Unknown
- 3. Time Transmission of Approved Action Product Ordered: Unknown
- 4. Time Transmission of Approved Action Product Effected: 13 2132
- 5. Hrs: Min. Between Completion of D.A.R. and Transmission of Product Effected: Unknown
- 6. Office Presenting D.A.R. for Approval: J-3 JBS Member
- 7. Method of Presentation of Product for Approval: Unknown
- 8. Offices Reviewing and Approving Action Product: Vice Dir J/ S, Dir J/S
- 9. Offices Contacted in Coordinating Action Approval: Unknown
- 10. Principal Action Office for Modifying D.A.R.: Unknown
- 11. Primary Modification: Unknown
- 12. Principal Function Performed in Modifying D.A.R.: Unknown

LOG NOTES AND COMMENTS

MESSAGE 26

1. At 13 2132Z(13 1732 EDT) CINCLANT is informed that funding for the exercise should be absorbable by the Services, and if funding problems exist "component commanders should direct requirements to respective chiefs of Service". LANT's 12 1748 is referenced.

2. Msg. drafted by J-3 member JBS, signed by Vice Dir. J/S, addressed Dir. J/S sends, time submitted not recorded, and for priority transmission.

3. CINCLANT's 12 1748 states that CONARC and TAC need additional training funds for OPLAN exercise, that Navy and USMC will also, and asks that steps be taken to make necessary funds available to Service Chiefs. Msg. received 12 1836. Action assigned to J-4 and "action shifted to J-3."

4. On 12 June at 1100 Vice Dir. J/S "requested revised talking paper to include costs by Services to present to Chiefs and Ops Deps this afternoon." (Apparently, CINCLANT had talked about it earlier with someone in JCS.)

5. On 12 June at 1215(log time) J-3 member JBS contacted AF Plans, TAC and Hq. Transport Division for AF "attitude on funding for exercise." At 1200 JBS D/O had called AF, Army and Navy to determine if Services could absorb cost of the exercise.

~~TOP SECRET~~

JOINT STAFF ACTIONS

A. Action Reference (Msg. Order No.)

Message 27

- | | |
|--------------------------------|--|
| 1. Type Action: | JCS Message |
| 2. Action Subject: | CPX authorized with training exercise of Naval Forces. |
| 3. Time J/S Action Culminated: | 14 0022 |

B. Action Requirement Generation

- | | |
|---|---|
| 1. Basic Cause: | Final stages of LAFT planning for exercise completed and authorization requested. |
| 2. Time of Occurrence: | Indefinite |
| 3. Requirement Recognition: | Discussions and messages to and from J/S |
| 4. Recognition Source: | CINCLANT |
| 5. Time of Recognition: | 12 0101 |
| 6. Time of Initial Receipt of Requirement Information in J/S: | 12 0240 |
| 7. J/S Contact Point: | JBS D/O |
| 8. Hrs: Min. from Time of Cause to Time J/S Informed: | 1:39 (From recognition) |
| 9. Hrs: Min. from Time of Cause to Time J/S Action Culminated: | 47:21 (From recognition) |
| 10. Hrs: Min. from Time J/S Informed to Time J/S Action Culminated: | 45:42 |

C. Establishing Requirement in J/S

- | | |
|---|---|
| 1. Time Requirement Information Received by Action Group: | 12~0300 |
| 2. Time Action Preparation Ordered: | 12~1200 |
| 3. Hrs: Min. Used in Establishing Requirement: | 0:00 |
| 4. Principal Time-Consuming Function: | None |
| 5. Initial J/S Action Assignment Point: | J-3 |
| 6. Principal Coordinating Functions Performed: | Previous liaison |
| 7. Lateral Liaison -- Offices Contacted: | AFCP, NFP, AWR, MCWR |
| 8. Higher Echelons Involved in Decision: | CJCS, SecDef |
| 9. Type Decision: | Personal conversation |
| 10. Prime Factor in Establishing Requirement: | Previous agreement to consider exercise |

7-13-62-72

~~TOP SECRET~~

~~TOP SECRET~~

D. Preparing Draft Action Recommendation (D.A.R.)

Message 27

- | | |
|---|----------------------------------|
| 1. Time Preparation of D.A.R. Begun: | 12~ 1200 |
| 2. Time Preparation of D.A.R. Formally Assigned: | 12~ 1200 |
| 3. Time D.A.R. Completed for Presentation: | 12 1500 |
| 4. Hrs: Min. used in Preparing D.A.R.: | ~3:00 |
| 5. Office Preparing D.A.R.: | J-3 Member JBS |
| 6. Office Ordering D.A.R. Preparation: | Vice Dir J/S |
| 7. Office Supervising Preparation of D.A.R.: | Dep Dir J-3 |
| 8. Type and No. of Personnel Assigned Action: | 1 Navy Capt. |
| 9. Principal Functions Performed: | Drafting Message |
| 10. Offices Contacted in Detailing the Requirement: | Vice Dir J/S |
| 11. Principal Data Source Utilized in Preparing D.A.R.: | LANT's 12 0101 |
| 12. Offices Contacted in Lateral Coordination: | Unknown |
| 13. Products Resulting: | Draft Message and talking paper. |

E. Modification and Approval of Action Product

- | | |
|---|--|
| 1. Time D.A.R. Submitted for Approval (to Higher Echelon Office) | 12~ 1900 |
| 2. Hrs: Min. Between Completion of D.A.R. and Consideration for Approval: | ~4:00 |
| 3. Time Transmission of Approved Action Product Ordered: | 14 0000 |
| 4. Time Transmission of Approved Action Product Effected: | 14 0022 |
| 5. Hrs: Min. Between Completion of D.A.R. and Transmission of Product Effected: | 33:22 |
| 6. Office Presenting D.A.R. for Approval: | Vice Dir J/S |
| 7. Method of Presentation of Product for Approval: | Briefing to JCS, Ops Dep,
Personal to CJCS and SecDef
As above. |
| 8. Offices Reviewing and Approving Action Product: | |
| 9. Offices Contacted in Coordinating Action Approval: | Military adviser to President,
State Dept, CINCLANT
J-3 |
| 10. Principal Action Office for Modifying D.A.R.: | J-3 |
| 11. Primary Modification: | CJCS |
| 12. Principal Function Performed in Modifying D.A.R.: | Decreasing scope of exercise
and notifying coordinating
offices. |

7-13-62-73

~~TOP SECRET~~

LOG NOTES AND COMMENTS

MESSAGE 27

1. At 14 0022Z(13 2022 EDT) CINCLANT is informed that CPX is authorized with all forces already assigned, a training exercise is authorized with Navy forces (only), and a nickname is given (AXEL GREASE). LANT is asked to submit proposed publicity for DOD approval. LANT's 12 0101 is referenced.

2. Writer not listed on msg., signed by Vice Dir. J/S, addressed from JCS, submitted at 1950 for Op-Immediate transmission.

3. LANT's 12 0101 (received 12 0240) gives proposed D-Day, units to report to CINCLANT for operational control, scale and length of operations, and requests nickname. J-3 was assigned action. This is LANT's answer to JCS 10 1811.

4. On 11 June 1530 J-3 member JBS called CINCLANT Plans to obtain their recommendations for exercising total airlift as info "on which the JCS may base their decision".

5. At 11 2300 EDT JBS D/O called Army, AF and USMC War Rooms "to look out for copies of LANT's 12 0101Z in preparation for 12 June JCS meeting with SecDef on LANT's request for test exercise."

6. At 12 1100 EDT J-3 member JBS submitted proposed JCS answer to CINCLANT's proposal to Dir. JBS. "Vice Dir. J/S approved with minor changes and requested talking paper to present to Chiefs and Ops Deps. this PM."

7. At 12 1815 EDT JBS prepared msg. to CINCLANT "in accordance with guidance received from JCS meeting" authorizing CPX. At 1900 Vice Dir. J/S checked this msg. out with Chairman who directed CINCLANT to be advised by phone of contents, and if LANT still wanted exercise, CJCS would clear with State and White House. Vice Dir. J/S directed JBS to call LANT staff and give background info and Vice Dir. would call CINCLANT next day.

MESSAGE 27 (Cont'd)

8. On 13 June at 0900 the Vice Dir. J/S called CINCLANT. At 0930 JCS meeting approved. During the day Dir. JBS checked with the military aide to the President at White House, and the Vice Dir. J/S checked with State. At 1450 JBS informed that the Vice Dir. had talked with CINCLANT re use of a BLT and CINCLANT control exercise. At 1700 CJCS announced he would clear msg. with SecDef and President before release. This info relayed to CINCLANT by JBS. At 13 2000 Vice Dir. J/S released authorizing msg. CINCLANT Flag Plot and all Service War Rooms were informed at 2020 by JBS that msg. was released.

[REDACTED]

JOINT STAFF ACTIONS

A. Action Reference (Msg. Order No.)

Message 28

- | | |
|--------------------------------|---|
| 1. Type Action: | JCS Message |
| 2. Action Subject: | Returns all units earmarked for
exercise to DEPCON 5 after |
| 3. Time J/S Action Culminated: | 15~2245 |

B. Action Requirement Generation

- | | |
|--|---|
| 1. Basic Cause: | Termination of crisis tension and
of exercise Axle Grease antici-
pated |
| 2. Time of Occurrence: | 13~1600 |
| 3. Requirement Recognition: | Planning conferences |
| 4. Recognition Source: | CINCLANT |
| 5. Time of Recognition: | 13 2126 (LANT recommendation) |
| 6. Time of Initial Receipt of
Requirement Information in J/S: | 14 0039 |
| 7. J/S Contact Point: | Unknown |
| 8. Hrs: Min. from Time of Cause
to Time J/S Informed: | ~ 8:39 |
| 9. Hrs: Min. from Time of Cause
to Time J/S Action Culminated: | ~ 54:45 |
| 10. Hrs: Min. from Time J/S Informed
to Time J/S Action Culminated: | ~ 46 hours |

C. Establishing Requirement in J/S

- | | |
|--|--|
| 1. Time Requirement Information
Received by Action Group: | 14 1630 |
| 2. Time Action Preparation Ordered: | 14~1630 |
| 3. Hrs: Min. Used in Establishing
Requirement: | 15:51 |
| 4. Principal Time-Consuming Function: | Unknown |
| 5. Initial J/S Action Assignment
Point: | JCS D/O |
| 6. Principal Coordinating Functions
Performed: | Phone calls |
| 7. Lateral Liaison -- Offices
Contacted: | LANT Plans, AFHQ Opns |
| 8. Higher Echelons Involved in
Decision: | J-3, Vice Dir J/S |
| 9. Type Decision: | Personal |
| 10. Prime Factor in Establishing
Requirement: | LANT and USAF requests to return
to peacetime training status |

~~TOP SECRET~~

D. Preparing Draft Action Recommendation (D.A.R.)

Message 28

- 1. Time Preparation of D.A.R. Begun: 14 1700
- 2. Time Preparation of D.A.R. Formally Assigned: 14 1630
- 3. Time D.A.R. Completed for Presentation: 14 1800
- 4. Hrs: Min. used in Preparing D.A.R.: 1:00
- 5. Office Preparing D.A.R.: J-3 Member JBS
- 6. Office Ordering D.A.R. Preparation: Vice Dir J/S
- 7. Office Supervising Preparation of D.A.R.: Dep Dir J-3
- 8. Type and No. of Personnel Assigned Action: 1 Col.
- 9. Principal Functions Performed: Message draft
- 10. Offices Contacted in Detailing the Requirement: LANT Staff
- 11. Principal Data Source Utilized in Preparing D.A.R.: CINCLANT's 13 2126
- 12. Offices Contacted in Lateral Coordination: LANT Staff, AFCP, AWR
- 13. Products Resulting: Draft Message

E. Modification and Approval of Action Product

- 1. Time D.A.R. Submitted for Approval (to Higher Echelon Office) 14 1800
- 2. Hrs: Min. Between Completion of D.A.R. and Consideration for Approval: None
- 3. Time Transmission of Approved Action Product Ordered: 15 2200
- 4. Time Transmission of Approved Action Product Effected: 15 2245
- 5. Hrs: Min. Between Completion of D.A.R. and Transmission of Product Effected: 28:45
- 6. Office Presenting D.A.R. for Approval: Dep Dir J-3
- 7. Method of Presentation of Product for Approval: Hand carried
- 8. Offices Reviewing and Approving Action Product: Vice Dir J/S, CJCS, SecDef, President
- 9. Offices Contacted in Coordinating Action Approval: State Op Ctr, Military Aide to President
- 10. Principal Action Office for Modifying D.A.R.: Unknown
- 11. Primary Modification: Unknown
- 12. Principal Function Performed in Modifying D.A.R.: Unknown

7-13-62-75

~~TOP SECRET~~

LOG NOTES AND COMMENTS

MESSAGE 28

1. At approximately 15 2245Z(15 1845 EDT) JCS message No. 997642 (not on file) apparently ends the J/S involvement in the DR crisis by returning military units to their peacetime stations and reversion to DEFCON 5.

2. LANT's 13 2126 received 14 0039Z recommended returning Army and AF units to DEFCON 5 on termination of exercise and holding certain Navy units on DEFCON 4. This msg. received by JBS on 14 June at 1230. Draft msg. accepting LANT recommendation prepared by JBS with supporting paper and hand-carried by Dir. JBS to Vice Dir. J/S at approximately 1400.

3. Director Hq AF Ops contacted Dir. J-3 and requested immediate return of AF units to DEFCON 5 on 14 June.

4. On 15 June 1200 EDT JBS called LANT Plans re meaning of DEFCON 4 for Navy forces.

5. Vice Dir. J/S contacted Chief State Ops Ctr. re reducing readiness status of forces - no State objections. Dir. JBS discussed same with military aide to President at White House - no objection and noted Presidential approval not believed to be required.

6. On 15 June 1800 CJCS cleared the proposal with SecDef and the President and "at 1845 msg. accomplishing same was dispatched".

7. Service War Rooms notified at 1900 and advance copies of msg. provided. On 16 June at 1420 JBS D/O called Army and AF War Rooms, and spelled out intent of the JCS msg. (Apparently the status of forces participating in AXLE GREASE was unclear.)

~~TOP SECRET~~

JOINT STAFF ACTIONS

A. Action Reference (Msg. Order No.)

Message 29

- | | |
|--------------------------------|---|
| 1. Type Action: | JCS Message |
| 2. Action Subject: | Cancellation of request for pre-positioning tanker with avgas reserves. |
| 3. Time J/S Action Culminated: | 16 2027 |

B. Action Requirement Generation

- | | |
|---|---|
| 1. Basic Cause: | Effective cancellation of measures to implement [] |
| 2. Time of Occurrence: | 10 ~ 0000 |
| 3. Requirement Recognition: | JCS Message |
| 4. Recognition Source: | CINCLANT |
| 5. Time of Recognition: | 14 ~ 2000 |
| 6. Time of Initial Receipt of Requirement Information in J/S: | 15 ~ 0000 (Received of LANT's 14 2312) |
| 7. J/S Contact Point: | J-4 |
| 8. Hrs: Min. from Time of Cause to Time J/S Informed: | 120 hours |
| 9. Hrs: Min. from Time of Cause to Time J/S Action Culminated: | 164 hours |
| 10. Hrs: Min. from Time J/S Informed to Time J/S Action Culminated: | ~44:30 |

C. Establishing Requirement in J/S

- | | |
|---|--|
| 1. Time Requirement Information Received by Action Group: | Unknown |
| 2. Time Action Preparation Ordered: | Unknown |
| 3. Hrs: Min. Used in Establishing Requirement: | Unknown |
| 4. Principal Time-Consuming Function: | Unknown |
| 5. Initial J/S Action Assignment Point: | J-4 |
| 6. Principal Coordinating Functions Performed: | Contacting MPSA |
| 7. Lateral Liaison -- Offices Contacted: | Unknown |
| 8. Higher Echelons Involved in Decision: | Unknown |
| 9. Type Decision: | Unknown |
| 10. Prime Factor in Establishing Requirement: | Formal answer to a formal request for action already taken |

7-13-62-76

~~TOP SECRET~~

D. Preparing Draft Action Recommendation (D.A.R.)

Message 29

- 1. Time Preparation of D.A.R. Begun: 16~1230
- 2. Time Preparation of D.A.R. Formally Assigned: Unknown
- 3. Time D.A.R. Completed for Presentation: Unknown
- 4. Hrs: Min. used in Preparing D.A.R.: Less than 7 hours
- 5. Office Preparing D.A.R.: J-4, Petroleum Br, R & C Div.
- 6. Office Ordering D.A.R. Preparation: J-4
- 7. Office Supervising Preparation of D.A.R.: J-4
- 8. Type and No. of Personnel Assigned Action: 1 Col.
- 9. Principal Functions Performed: Coordinating with MPSA
- 10. Offices Contacted in Detailing the Requirement: MPSA
- 11. Principal Data Source Utilized in Preparing D.A.R.: CINCLANT telecom of 10 June
- 12. Offices Contacted in Lateral Coordination: Unknown
- 13. Products Resulting: Draft Message

E. Modification and Approval of Action Product

- 1. Time D.A.R. Submitted for Approval (to Higher Echelon Office) Unknown
- 2. Hrs: Min. Between Completion of D.A.R. and Consideration for Approval: Unknown
- 3. Time Transmission of Approved Action Product Ordered: 16 1930
- 4. Time Transmission of Approved Action Product Effected: 16 2027
- 5. Hrs: Min. Between Completion of D.A.R. and Transmission of Product Effected: Unknown
- 6. Office Presenting D.A.R. for Approval: Unknown
- 7. Method of Presentation of Product for Approval: Unknown
- 8. Offices Reviewing and Approving Action Product: J-4
- 9. Offices Contacted in Coordinating Action Approval: Unknown
- 10. Principal Action Office for Modifying D.A.R.: Unknown
- 11. Primary Modification: Unknown
- 12. Principal Function Performed in Modifying D.A.R.: Unknown

LOG NOTES AND COMMENTS

MESSAGE 29

1. At 16 2027Z(16 1627 EDT) CINCLANT is informed that per his request, MPSA will take no further action on prepositioning of tanker with Avgas reserves at San Juan. LANT's 07 1538, JCS 08 2010 and LANT's 14 2312 are referenced.
2. Msg. written by Petroleum Branch, R&C Div., J-4, signed by J-4 "Secretary", addressed from JCS, J-4 sends, and submitted at 1530 for routine transmission.
3. LANT's 14 2312 received 15 0434Z requests cancellation of his 07 1538. J-4 assigned action and J-4 note on msg. says "Action by MPSA had been suspended last week by CINCLANT telecon" (probably on 10 June). No record of receipt of 14 2312 in JBS D/O log.

APPENDIX "C"

INFORMAL JBS COMMUNICATIONS RECORDED
IN JBS LOGS

INFORMAL JBS COMMUNICATIONS RECORDED IN JBS LOGS
 (Phone Conversations, Briefings, Meetings, and Miscellaneous Communications)

DATE	TIME (EDT)	TYPE CONTACT	OFFICES INVOLVED	SUBJECT AREA	FUNCTIONS PERFORMED BY JBS
31 May	0400	Personal	J-2	Report (CRITIC #1) of Trujillo's death	Received abstracted information.
	0405	Phone	Service War Rooms	Report (CRITIC #1) of Trujillo's death	Relayed message.
	0930	Meeting	Vice Dir., J/S	DR situation	Received guidance for sending message to CINCLANT re implementation of []
	0953	Personal	J-2	Report (CRITIC #2) Bishop Reilly's confirmation of Trujillo's death	Received information (no note of notifying other offices).
	1038	Phone	CIA	Conditions within DR	Received information - no action.
	1115	Phone	CINCLANT DO	Preparatory actions for []	Alerted to incoming message from CINCLANT.
	1410	Phone	Navy Flag Plot	Ships movements	Received information.
	1630	Personal	JCS	Support plans for DR from JCS meeting	Preparation of data for State-Defense meeting at 1730.
	2145	Phone (?)	CNO MSTS	Shipping requirement	Received information (relayed?).

DATE	TIME (EDT)	TYPE CONTACT	OFFICES INVOLVED	SUBJECT AREA	FUNCTIONS PERFORMED BY JBS
1 Jun	0700	Phone	Army War Room	Readiness of Forces (DEFCON Conditions)	Requested information - as follow-up to State-Defense meeting 31 May at 1730.
	0710	Phone	AFCP	Readiness of forces (DEFCON Conditions)	Requested information - as follow-up to State-Defense meeting 31 May at 1730.
	0802	Phone	AFCP	Readiness of forces (DEFCON Conditions)	Collected information - in answer to query - to be passed to JCS members.
	1040	Phone	Army War Room	Readiness of forces (DEFCON Conditions)	Collected information - in answer to query - to be passed to JCS members.
	1030	Briefing	JCS Vice Dir., J/S	Details of DR plan	Prepared and presented data.
	1800	Personal	Vice Dir., J/S	Revision of contingency plan and augmentation of forces.	Prepared and sent message to CINCLANT and the Services as result of JCS and Ops.Deps. meeting.
	1835	Phone	CINCLANT plans	Marine units involved in DR plan	Collected information - to be passed to Vice Dir., J/S if he called for it.
	1840	Meeting	OSD (PA) Rep.	Ships movements	Consultation - re publicity given to ships movements from East Coast ports.

DATE	TIME (hr)	TYPE CONTACT	OFFICES INVOLVED	SUBJECT AREA	FUNCTIONS PERFORMED BY JBS
1 Jun (Cont'd)	1840	Phone	CINCLANT PIO	Press release on ships movements	Collected information - confirmation of CINCLANT's press release - "routine operations".
	1845	Phone	CINCLANT DO	Ships movements	Collected information - ships movements status.
	1900	Phone	CINCLANT Plans	Military augmentation	Reaffirmed information - JCS approval of personnel increase.
	1915	Personal	Vice Dir., J/S	Ships movements Deployment of more forces in area.	Received information - to release part of modified JCS msg. to CINCLANT.
	1925	Phone	Sec Def aide	Reconnaissance photos	Received request for handling.
	1940	Phone	CINCLANT DO	Reconnaissance photos	Received information re time of delivery - to be passed to Sec Def.
	2045	Phone conference	Chairman, JCS Chief of Naval Ops. Vice Dir., J/S	Ships contacts and problems of restrictions of ships movements for reconnaissance.	Collected information - results to be relayed to CNO DO.
	2130	Phone	CNO DO	Reconnaissance of ship contacts	Relayed information - result of telecon at 2045 to be passed to CINCLANT by CNO DO.
	2205 and 2345	Phone (2)	CNO DO	Reconnaissance photos	Received information - timing for processing and delivering recce photos to JWR.

DATE	TIME (EDT)	TYPE CONTACT	OFFICES INVOLVED	SUBJECT AREA	FUNCTIONS PERFORMED BY JBS
2 Jun	0715	Personal	USN Photo Interpretation Center	Photoreconnaissance	Received information - photo-interpretation report on DR photoreconnaissance
	0720	Personal	Reproduction Center, JCS	Situation Report No. 2	Preparation and delivery of data.
	0725	Phone	Sec Def	Photoreconnaissance	Relayed information - results of photoreconnaissance
	0800	Personal	White House aide State rep.	Photoreconnaissance	Presentation of data --- received from photo interpretation center.
	1100	Personal	Sec Def Vice Dir., J/S	Augmentation of forces	Received and transmitted information - msg. cleared, to be sent to CINCIANT and Services. (Result of State-Defense meeting 1 Jun.)
	1125	Phone (2)	White House military rep. State rep.	Augmentation of forces	Relayed information - re JCS msg. above.
	1250	Phone	Navy Flag Plot	Ships movements	Received information - for records (DD visits to Haiti)
	1600	Phone	CINCLANT	Augmentation of forces	Received information - for record (ETA of ships and Marines).

DATE	TIME (EDT)	TYPE CONTACT	OFFICES INVOLVED	SUBJECT AREA	FUNCTIONS PERFORMED BY JBS
2 Jun (Cont'd)	1723	Phone	CINCLANT DO	Publicity to be given DR situation	Transmitted information - (forthcoming change in JCS order).
	1800	Phone (2)	CINCLANT DO Navy Flag Plot	Photoreconnaissance	Transmitted information - on handling of photoreconnaissance and interpretation.
	1830	Personal	Vice Dir., J/S	Joint operations with Venezuelan forces.	Released msg. to CINCARIB requesting information on sub- ject indicated.
	1845	Phone	CINCLANT DO	Augmentation of forces	Received information - for record (Departure of Marines and amphibs).
	1900	Phone	Dir., J/S	Conditions within Cuidad Trujillo	Received information with request to check.
	1915	Phone (5)	J-2; Army War Room; AFCP; NFP; State Operations Center	Conditions within Cuidad Trujillo	Requested information - follow-up of phone call at 1900. Copy of msg. later picked up at White House.
	(?)	Personal	AWR; Navy FP; AFCP	Map disposition of Service forces for SITREP	Request for information - needed to prepare SITREP.
	1945	Phone	State Op. Ctr. DO	DR situation	Received information - re State-Defense meeting.
	1950	Phone	Dir., J/S	DR situation	Transmitted information of above.
	2015	Phone	State Op. Ctr.	Conditions within Cuidad Trujillo	Received information - evidently no action.

DATE	TIME (EDT)	TYPE CONTACT	OFFICES INVOLVED	SUBJECT AREA	FUNCTIONS PERFORMED BY JBS
2 Jun (Cont'd)	~2050	Personal	Vice Dir., J/S Dir., J/S	Reaction Times DEFCON conditions Possible changes in CINCLANT's plans	Preparations of data - for meeting of CJCS with State.
	2330	Phone	CINCLANT Op. Officer	Ships movements	Received request to obtain permission for show of force. Transmitted request to Dir., J/S.
	2400	Phone	Dir., J/S	Ships movements	Received request to obtain more information on above phone call.
	2400	Phone	CINCLANT Op. Officer	Ships movements	Received information - no further action taken.
3 Jun	0010	Phone	Dir., J/S	Ships movements	Transmitted information obtained above.
	0145	Phone	Dep. CINCLANT Dir., J/S	Results of meeting with State	Transmitted information - relayed phone call to Dir., J/S.
	0210	Phone	USAF Duty Officer	Navy personnel at Ramey AFB	Received information - for record.
	0830	Briefing	Dir., J/S	DR situation	Transmitted information.
	0900	Briefing	Vice Dir., J/S	DR situation	Transmitted information.
	1000	Conference	Chairman, JCS Dir., Vice Dir., J/S Dep. Dir's., J-3	DR planning, including airborne operation planning	Received information - requested to send 2 JBS members to look into airborne planning at CINCLANT headquarters.

DATE	TIME (EDT)	TYPE CONTACT	OFFICES INVOLVED	SUBJECT AREA	FUNCTIONS PERFORMED BY JBS
3 Jun (Cont'd)	1020	Phone	Navy Op-61	Routing of State messages	Received request - to pass to Vice Dir., J/S - who will pass to State.
	1030	Personal	Vice Dir., J/S	Routing of State messages	Relayed above request and discussed with Vice Dir., J/S.
	1030	Personal	USN Photo Interpretation Center	Photoreconnaissance	Received recce photos.
	1155	Phone	CINCLANT Plans	Personnel request	Received request for approval (Army CAT member with Marine Brigade).
	1200	Personal	Vice Dir., J/S	Personnel request	Received approval of above request.
	1215	Phone	CINCLANT Plans	Personnel request	Relayed Vice Dir., J/S approval.
	1655	Phone	Vice Dir., J/S	Routing of State message 1290	Received instruction to pass copy of message to CINCLANT.
	2015	Phone	CINCLANT	Ships movements (BOXER underway)	Received information - for record.
	2125	Phone	JBS members, Norfolk	Airborne planning	Received report that mission was completed.
	2350	Phone	Navy Flag Plot	Status of ship's readiness	Received information.

SECRET

SECRET

DATE	TIME (EDT)	TYPE CONTACT	OFFICES INVOLVED	SUBJECT AREA	FUNCTIONS PERFORMED BY JBS
4 Jun	0835	Phone	SAMAA Rep., ISA	Query re State message 1318	Received request for information.
	1005	Phone	Dep. Dir., J-3	DR situation status and query re show of force.	Received information and request for information.
	1015	Phone	J-2	State message 1318	Received request for information to check.
	1025	Phone	SAMAA Rep., ISA	State meeting re show of force	Received information on State meeting.
	1055	Phone	SAMAA Rep., ISA	DR situation status	Received request for information.
	1056	Phone	SAMAA Rep., ISA	State meeting	Received information and asked to pass information.
	1111	Phone	Dep. Dir., J-3	State message 1318	Received permission to re-address message to CINCLANT and CINCARIB.
	1119	Phone	Navy Flag Plot	State meeting	Transmitted information on details re State meeting.
	1130	Personal	Message Center	State message 1318	Directed Message Center to send State message for information to LANT and CARIB.
	1410	Phone (?)	Navy Flag Plot	State message 1321	Discussed message - to contact vice CNO.

DATE	TIME (EDT)	TYPE CONTACT	OFFICES INVOLVED	SUBJECT AREA	FUNCTIONS PERFORMED BY JBS
4 Jan (Cont'd)	1445	Phone	Navy Flag Plot	State message 1321	Further instructions received on information. (Directed Message Center to increase precedence and add COMSECONDFLT for information.)
	1500	Personal	J-2	FBI Report	Received information.
	1530	Personal	Special Assistant to Chairman, JCS	State messages 1318 and 1321	Requested to provide copies for CJCS.
	1610	Phone	Op. 30, CINCLANTFLT Staff	Airborne operational planning	Received request for latest information to take to Norfolk (JBS asked him, in return, to check on something).
	1614	Phone	Dep. Dir., J-3	Planned locations during evening	Received information - for record - to be able to locate.
	1622	Personal	Aide to CJCS	State messages 1318 and 1321	Provided messages to be given to CJCS.
	1900	Phone	Army War Room	DEFCON status reached by augmentation units	Received information.
	2105	Phone	Vice Dir., J/S	DR situation	Situation report given.
	2115	Phone	Navy Flat Plot	Ship movements (Haiti)	Received information - re 48-hr. extension of ships at Haiti.

DATE	TIME (EDT)	TYPE CONTACT	OFFICES INVOLVED	SUBJECT AREA	FUNCTIONS PERFORMED BY JBS
4 Jun (Cont'd)	2230	Briefing	Dep. Dir., J-3	Airborne operations	Gave dry run on presentation to Chairman.
5 Jun	0300	Phone	AFCP	Navy personnel at Ramey AFB	Received information - to pass to CINCLANT DO.
	0300	Phone	CINCLANT DO	Navy personnel at Ramey AFB	Transmitted information - re AFCP complaint.
	0710	Personal	Reproduction Center	Situation Report No. 5	Preparation and dispatch of data.
	0845	Briefing	Vice Dir., J/S	Situation Report	Brought situation report up to date.
	0900	Phone	CINCLANT Staff Officer	Air reconnaissance	Relayed information re CINCLANT desiring to establish an air recce over DR.
	0915	Phone	State Operations Center	Ship movement	Received information re stationing of DD.
	0950	Phone	State Operations Center	Ship movement for show of force.	Received information of State approval of stationing of DD.
	0955	Phone	Secretary of Defense	Ship movement	Transmitted information of State approval of above.

DATE	TIME (EDT)	TYPE CONTACT	OFFICES INVOLVED	SUBJECT AREA	FUNCTIONS PERFORMED BY JBS
5 Jun (Cont'd)	0955	Personal	Message Center	Ship movement	Gave message to be sent to CINCLANT.
	1000	Phone	CINCLANT Plans	Reaction times Ship movements	Received and, in turn, gave out information that LANT not to make move without JCS instructions.
	1200	Personal	Vice Dir., J/S	Ship movements	Received permission to release message re stationing of DD.
	1210	Phone	CINCLANT War Room	Ship movements (time on station for BOXER)	Requested and received information.
	1215	Phone	Vice Dir., J/S	Ship movements (time on station for BOXER)	Transmitted information re above.
	1330	Briefing	JCS Dep. Dir. J-3	Current plans for use of augmented force.	Briefed in detail.
	1630	Phone	CINCLANT	Search and rescue plans	1) Received request for clarification on requirements. 2) Requested copies of SAR plan for airborne phase be sent to JCS.

DATE	TIME (EDT)	TYPE CONTACT	OFFICES INVOLVED	SUBJECT AREA	FUNCTIONS PERFORMED BY JBS
5 Jun (Cont'd)	1730	Phone	Army Staff	Briefing to JCSC 1330 Was J-2 involved?	Received request - to check.
	1730	Phone	Dep. Dir., J-3	Briefing to JCSC 1330 Was J-2 involved?	Requested information.
	1740	Phone	Army Staff	Briefing to JCSC 1330 Was J-2 involved?	Relayed information in reply to request.
	1745	Conference	Dir., J/S	DR situation re observer teams, and no further attempt to urge Balaguer to request U.S. assistance	Received information.
	1750	Phone	SAMAA rep., ISA	Current DR situation	Passed information received from Dir., J/S.
	1830	Phone	J-2 DO	Current DR situation	Passed information received from Dir., J/S.
	1910	Phone	Emergency Actions Group	Quarters check	Upon request, monitored weekly quarters check.
	1940	Phone (4)	Army, Navy, AF, USMC	Quarters check	Passed information received from Dir., J/S.
	2040	Phone	Navy Flag Plot DO	Press release (Argentina in OAS observer team)	Received information - requested to check on.
	2045	Phone	State Operations Center	Press release (Argentina in OAS observer team)	Checked information and received confirmation.

TOP SECRET

TOP SECRET

DATE	TIME (EDT)	TYPE CONTACT	OFFICES INVOLVED	SUBJECT AREA	FUNCTIONS PERFORMED BY JBS
5 Jun (Cont'd)	2320	Phone	Navy Flag Plot	OAS Observer Team	Received recommendation for message to be sent by JCS.
	2325	Phone	State Department	OAS Observer Team	Requested information on official State release on OAS Observer Team.
	2333	Phone	Navy Flag Plot	OAS Observer Team	Transmitted that no information on above will be released this date.
6 Jun	0715	Personal	Reproduction Center	Situation Report No. 6	Preparation and dispatch of data. Advance copies to AWR, NFP, AFCP.
	0900	Personal	Dep. Dir., J-3	Pre-D-hour air assault	Received instructions to send message to CINCLANT to advise on current status of the question of guidance.
	0930	Personal	Vice Dir., J/S	DR situation	Directed to prepare briefing book for CJCS meeting with President.
	1115	Briefing	Chairman, JCS	DR situation	Preparation of briefing book and briefing on.

TOP SECRET

- 165 -

Appendix "C"

DATE	TIME (EDT)	TYPE CONTACT	OFFICES INVOLVED	SUBJECT AREA	FUNCTIONS PERFORMED BY JBS
6 Jun (Cont'd)	1230	Briefing	USMC attaché to DR Dep. Directors, J-3	DR situation	Received briefing by USMC attaché (re terrain, armed forces, political situation, and evaluation).
	1430	Briefing	Chief of Military Mission in Haiti	Haiti situation	Received briefing by Chief of Military Mission to Haiti.
	1600	Personal	Dir. and Vice Dir., J/S	Reconnaissance missions	Received information on dis- continuance of reconnaissance missions over DR.
	1700	Phone	CINCLANT Staff	Reconnaissance missions	Check and confirmation of information received at 1600.
	2055	Phone	Dep. Dir., J-3	CINCARIB message	Check re need for action on message. Directed action in morning.
7 Jun	0650	Personal	Reproduction Center	Situation Report No. 7	Preparation and dispatch of SITREP.
	1330	Personal	Vice Dir., J/S	Briefing books	Ordered to prepare 2 more briefing books.
	1610	Phone	AFCP	OAS Inspection Team	Received information of landing at CT of OAS Inspec- tion Team.
	1830	Briefing	Chairman, JCS	Meeting at White House	JBS debriefed CJCS - no action to be taken.

TOP SECRET

TOP SECRET

DATE	TIME (EDT)	TYPE CONTACT	OFFICES INVOLVED	SUBJECT AREA	FUNCTIONS PERFORMED BY JBS
8 Jun	0700	Personal	Reproduction Center	Situation Report No. 8	Preparation of data and delivery.
	2045	Personal	Dep. Dir., J-3	Talking paper for State-JCS meeting	Preparation of data - sent for signature.
9 Jun	0635	Personal	Reproduction Room	Talking paper for State-JCS meeting	Delivered paper.
	0715	Personal	Reproduction Room	Situation Report No. 9	Preparation and delivery of data.
	1230	Phone	CINCLANT Staff	Test exercise	Received information (re requesting JCS to approve test of [])
	1500	Personal	Vice Dir., J/S	Reduction of readiness posture	Preparation of draft message to CINCLANT.
	1730	Personal	Vice Dir., J/S	Reduction of readiness posture	Received information re message above. CJCS to take up substance of message with Sec. of Def.
	1900	Personal	JCS	Reduction of readiness posture	Received JCS approval of message to CINCLANT.
10 Jun	0715	Personal	Reproduction Center	Situation Report No. 10	Preparation and delivery of data.

DATE	TIME (EDT)	TYPE CONTACT	OFFICES INVOLVED	SUBJECT AREA	FUNCTIONS PERFORMED BY JBS
10 Jun (Cont'd)	1125	Phone	Staff Officer, CARIBCOM	Reduction of readiness posture	Received information re Canal Zone Forces.
	1240	Phone	?	Reduction of readiness posture	Received information re CARIBCOM.
	1340	Personal	Vice Dir., J/S	1) Test exercise	1) Told to release message cleared by CJCS.
				2) Readiness of forces for test.	2) Told to consider message.
1830	Phone	?	Reduction of readiness posture	Received information on Antilles Def. Com. Carib. Sea frontier.	
11 Jun	0500	?	CINCLANT	Division of forces for test exercise and DR patrol.	Received information on.
	0715	Personal	Reproduction Center	Situation Report No. 11	Preparation and delivery of.
	1530	Phone	CINCLANT plans	Force units for test exercise	Request for and collection of data for JCS to base decision.
	1535	Phone	AFCP	Reaction times to TAC	Requested information for relay to Vice Dir., J/S.
	1535	Phone	Army War Room	Reaction times to TAC	Requested information for relay to Vice Dir., J/S.

TOP SECRET

TOP SECRET

DATE	TIME (EDT)	TYPE CONTACT	OFFICES INVOLVED	SUBJECT AREA	FUNCTIONS PERFORMED BY JBS
11 Jun (Cont'd)	2300	Phone	Army, USAF, and USMC War Rooms	Test exercise	Alerted these offices for copies of message from CINCLANT in preparation for 12 June JCS meeting with Sec. of Def.
12 Jun	0700	Personal	Reproduction Center	Situation Report No. 12	Preparation and dispatch of data.
	1100	Conference	Dep. Dir., J-3	Test exercise	Relayed information on develop- ment of proposed answer to CINCLANT's exercise proposal.
	1100+	Personal	Vice Dir., J/S	Test exercise	Received approval and were requested to prepare a revised talking paper to include costs by Services.
	1215	Phone	AF plans	Test exercise	Requested information re attitude for funding.
	1220	Phone	TAC	Test exercise	Requested information on funding.
	1220	Phone	USAF Transport Division Headquarters	Test exercise	Requested information on funding.
	1615	Personal	Dep. Dir., J-3	Test exercise	Received information re discussion with White House aide.
	1815	Personal	JCS	Test exercise	Received guidance from JCS meeting and prepared message to CINCLANT re conducting CPX.

DATE	TIME (EDT)	TYPE CONTACT	OFFICES INVOLVED	SUBJECT AREA	FUNCTIONS PERFORMED BY JBS
12 Jun (Cont'd)	1900	Personal	Vice Dir. J/S	Test exercise	Received information - directed to contact CINCLANT staff.
	1930	Phone	CINCLANT staff	Test exercise	Checked and discussed LANT's desire for exercise.
	1940	Phone	Vice Dir., J/S	Test exercise	Relayed information obtained above.
	1945	Phone	CINCLANT staff	Test exercise	Advised of conversation with Vice Dir., J/S.
	2045	Phone	Dep. Dir., J-3	Test exercise	Briefed Dep. Dir., J-3 re above information.
13 Jun	0705	Personal	Reproduction Room	Situation Report No. 13	Prepared and dispatched.
	0900	Meeting	Vice Dir., J/S	Test exercise	Received information and were directed to check with State Department and White House for information prior to JCS meeting.
	1000	Personal	Dir., J/S	Battle Staff duty hours	Received authorization to reduce on-duty coverage.
	1130	Phone	OSD (PA) Rep.	Publicity for exercise	Requested guidance for proposed message to CINCLANT on exercise.
	1200	Phone	USAF, Army, and Navy	Cost of exercise	Requested information.

DATE	TIME (EDT)	TYPE CONTACT	OFFICES INVOLVED	SUBJECT AREA	FUNCTIONS PERFORMED BY JBS
13 Jun (Cont'd)	1450	Personal	Dep. Dir., J-3	Test exercise	Received information re exercise plans.
	1700	Personal	Dep. Dir., J-3	Test exercise	Received information - asked to notify CINCLANT.
	1700	Phone	CINCLANT	Test exercise	Notified CINCLANT of above.
	2000	Personal	Vice Dir., J/S	Test exercise	Told to release message authorizing CPX.
	2000	Phone	CINCLANT Flag Plot	Test exercise	Released message re above.
	2020	Phone	AFCP NFP Army War Room	Test exercise	Relayed information re above.
14 Jun	0745	Briefing	Dep. Dir., J-3	DR status	Preparation of data.
	0815	Briefing	Vice Dir., J/S Dep. Dir., J-3	DR status	Preparation of data.
	1230	Phone (?)	CINCLANT	Lifting of DEFCON condition for Army, Navy, and AF	Received request from CINCLANT to follow up.
	1230	Phone	Dir., J-3	DEFCON for AF	Received information on AF units - re DEFCON condition.

DATE	TIME (EDT)	TYPE CONTACT	OFFICES INVOLVED	SUBJECT AREA	FUNCTIONS PERFORMED BY JBS
14 Jun (Cont'd)	1230	Personal	Vice Dir., J/S Dep. Dir., J-3	DEFCON for Army and AF	Drafted message to CINCLANT and delivered to Vice Dir., J/S.
15 Jun	1200	Phone	CINCLANT staff	DEFCON for Navy forces	Requested and received clarification on meaning of DEFCON 4 for Navy units
	1300	Personal	Vice Dir., J/S	Reduction of readiness status of forces earmarked for []	Received information re Vice Dir., J/S contact with State Department.
	1310	Personal	Dep. Dir., J-3	Reduction of readiness status of forces earmarked for []	Received information re Dep. Dir., J-3 contact with White House.
	1800	Phone (?)	Chairman, JCS	Reduction of readiness status of forces earmarked for []	Received information that proposal was cleared. Prepared and dispatched message.
	1900	Phone (3)	Service War Rooms	Reduction of readiness status of forces	Relayed information that message had been dispatched, and provided copies.
16 Jun	0710	Personal	Reproduction Room	Situation Report No. 13	Preparation and dispatch.
	1420	Phone (2)	Army and AF War Rooms	DEFCON condition after exercise	Instructed re JCS intent.

DATE	TIME (EDT)	TYPE CONTACT	OFFICES INVOLVED	SUBJECT AREA	FUNCTIONS PERFORMED BY JBS
17 Jun	0902	Phone	Dep. Dir., J-3	JBS mbr's. request (?)	Read message and received approval on request.
	0910	Phone	CINCLANT staff	JBS mbr's. request (?)	Requested passing approval to JBS member at CINCLANT via voice radio.
	0935	Phone	CINCLANT staff	JBS mbr's. request (?)	Received information re whereabouts of JBS member.